



The Republic of Uganda

Ministry of Gender, Labour and Social Development

Technical Design Manual
for
Labour Intensive Public Works

Volume II

September 2016



The Republic of Uganda

Ministry of Gender, Labour and Social Development

Technical Design Manual
for
Labour Intensive Public Works

Volume II

Acknowledgment

The Ministry of Gender, Labour and Social Development (MGLSD) would like to appreciate all people who contributed to the successful completion and publication of this manual. First and foremost, special appreciation goes to DFID (Uganda), Irish Aid, World Bank and World Food Programme for funding the development of this manual. In addition the Ministry appreciates the Consultant, Mr Arega Yirga from WFP Ethiopia, for the invaluable time and effort he put in leading the development of this technical design manual. The Ministry is also grateful to Mr. Sorssa Natea and Ian Campbell, the Consultants who complemented the work of Mr Arega by developing volume one of the National Labour Intensive Public Works Guidelines.

Specific thanks go to Mr. Michael Dunford (WFP Representative and Country Director), Mr. Stephen Kasaija (Head, Social Protection Secretariat, MGLSD/ESP), Mrs. Christine Wright (Head of Safety Nets and Resilience Unit, WFP), Mrs. Beatrice Okillan (Policy and Learning Manager, Social Protection Secretariat, MGLSD/ESP), Mr. Ross Smith (Head of Programme Unit, WFP), Mr. Endeshaw Tadesse, (Senior Social Protection Specialist, World Bank), Mr. David Tumwesigye (Policy and Advocacy Advisor, Social Protection Secretariat, MGLSD/ESP), and Mr. Zephaniah Ogen (M&E Officer, Social Protection Secretariat, MGLSD/ESP), Ms. Lydia Nabiryo (Policy and Advocacy Officer, MGLSD/ESP), Mr. Patrick Yankuba (Head of WFP Area Office in Karamoja), and Mr. Komakech Charles (Disaster Management Officer, OPM who provided valuable guidance, support and constructive advice in the development of the manual.

The Ministry is also grateful to: Mr. Menyah Gerald (Assistant Commissioner, Office of Prime Minister), Dr. Robert Limlim (Director of NUSAF2), Mr. Engineer Richard Cong (Assistant Commissioner, MWE), Mrs. Margaret Mwebesa (Assistant Commissioner, MWE), Dr. Mbadhwe John (Director, Ministry of Work and Transports), Mr. Stephen Biribonwa (Senior Agricultural Officer, Food & Nutrition, MAAIF), Mr. Sirak Mehari (Head of Programme, DRC), and other respective ministries staff who shared and provided very valuable information, suggestions, opinions and constructive advice in the process of developing the technical design manual.

Finally, appreciations go to all WFP staff, NGOs, Development Partners, and district staff in Moroto, Napak, Kotido, Kaabong, Bududa, Nakasongola, Sembabule and Kasese. who shared and provided their unreserved thoughts, feedback and necessary information during the field visit.

Foreword

This technical design manual for Labour Intensive Public Works (LIPW) has been prepared upon the request of the key stakeholders in the area of labour intensive public works. It has purposefully been prepared to provide practical guidance for experts, field level technicians and extension workers to design and implement potential Labour Intensive Public Works (LIPWs) sub-projects that can create community assets and show measurable results in resilience building. The manual is expected to provide useful guidance to district technical staff, extension workers and development partners on proper design and implementation of labour intensive public works sub-projects with social protection objectives.

This technical design manual has highlighted selection of common techniques and technologies that are suitable and appropriate for protection of gully erosion and rehabilitation, rainwater harvesting, moisture conservation, runoff water harvesting and storage, moisture harvesting, physical and biological soil conservation, flood control and drainage, stream bank erosion protection, spring development, design of shallow hand dug well, small scale irrigation, low cost soil fertility improvement, community road construction, afforestation and closed area management activities.

While preparing this technical manual, consultations with key stakeholders involved in implementation of LIPW projects and from districts where such projects are likely to be implemented was conducted in order to ensure that it is a practical working guidance for the field level technical staff and extension workers. This manual complements Volume I of the LIPW Guidelines and contains various diagrams and drawings to simplify the design of labour intensive public works sub-projects.

It is, therefore, envisaged that this technical manual will serve as an instrumental and useful field guide for the design and implementation of demand-driven labour intensive public works sub-projects as well as other promotional rural development interventions geared towards addressing risks and vulnerabilities affecting the population.

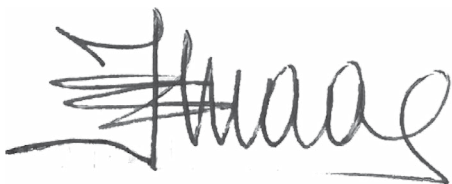

Pius Bigirimana
PERMANENT SECRETARY
Ministry of Gender, Labour and Social Development

Abbreviations and Acronyms

CAO	Chief Administrative Officer
DMO	Disaster Management Office
DRC	Danish Refugee Council
DREF	Disaster Relief Emergency Fund
ESP	Expanded Social Protection
Ha	Hectare
HD	Horizontal Distance
HI	Horizontal Interval
LIPW	Labour Intensive Public Works
M&E	Monitoring and Evaluation
MAAIF	Ministry of Agriculture, Animal Industry and Fisheries
MGLSD	Ministry of Gender, Labour and Social Development
MWE	Ministry of Water and Environment
NUSAF	Northern Uganda Social Action Fund
OPM	Office of the Prime Minister
PD	Person-day
PWP	Public Work Programme
RWH	Runoff Water Harvesting
SSD	Sediment Storage Dam
SSI	Small Scale Irrigation
SWC	Soil and Water Conservation
SWCM	Soil and Water Conservation Management
VI	Vertical Interval
WB	World Bank
WFP	World Food Programme

Table of Contents

1	Background and justification.....	14
1.1	Introduction to the Technical Design Manual.....	14
1.2	Rationale for the Technical Design Manual.....	14
1.3	Selection of Technologies for Labour Intensive Public Works.....	15
1.4	Identification and Prioritization of Techniques and Technologies.....	15
1.5	Basic Social Infrastructure Services.....	16
1.6	Key Integration and Sequencing of Technologies.....	16
1.7	Technical Skill Requirement for Technologies.....	16
1.8	Training Phases and Minimum Level of Education.....	16
2	Design and Construction of Gully Control Measures.....	18
2.1	Description.....	18
2.2	Causes of Gully Erosion.....	18
2.3	Principles of Gully Control.....	19
2.4	Main Processes of Gully Formation.....	19
2.5	Basic Gully Control Design and Construction Principles.....	20
2.6	Structural Gully Control Measures.....	22
2.7		23
2.8	Temporary Diversion and Retention of Excess Water-flow.....	24
2.9	Gully Check Dams Gully Control Measures.....	25
2.10	Design of Key for Check Dams.....	26
2.11	Spacing of Check Dams.....	27
2.12	Gabion Check Dams.....	28
2.13	Brushwood Check Dams.....	28
2.14	Log Check Dams.....	30
2.15	Gully Plugging.....	30
3	Design and Construction of Soil and Stone Bunds.....	31
3.1	Description.....	31
3.2	Basic Principles for Contour Soil and Stone Bunds.....	31
3.3	Design of Semi-circular Bunds.....	32
3.4	Operation and Maintenance.....	32
4	Design and Construction of Hillside Terraces.....	35
4.1	Description.....	35
4.2	Purpose and Scope of Level Terraces.....	36
4.3	Criteria for Selection of Terraces.....	37
4.4	Technical Specification for Terrace Design and Construction.....	39
4.5	Planting Soil Bund Terraces.....	40
5	Community-based Rainwater Harvesting Technologies.....	41
5.1	Description.....	41

5.2	Priorities of Community.....	44
5.3	Basic Technical Criteria for Water Harvesting.....	45
5.4	Prerequisites for Effective Water Harvesting.....	45
5.5	Challenges and Opportunities of Rainwater Harvesting in Karamoja.....	47
6	Design and Construction of Moisture Harvesting Terraces.....	49
6.1	Description.....	49
6.2	Basic Design Principles.....	49
6.3	Technical Challenges.....	52
6.4	Sustainability Factors for Zai Planting.....	52
6.5	Operation and Maintenance.....	53
7	Design and Construction of Negarim Micro-basin.....	54
7.1	Description.....	54
7.2	Layout and Construction of Negarim Micro-catchment.....	55
7.3	Maintenance and Husbandry.....	57
7.4	Socio-economic Considerations.....	57
8	Design and Construction of Bench Terraces.....	58
8.1	Description.....	58
8.2	Limitations.....	58
8.3	Design Parameters.....	58
8.4	Types of Bench Terraces and Criteria for Selection.....	59
8.5	Design Specification and Construction Guides.....	60
8.6	Diagram of Bench Terrace.....	63
8.7	Nomograph for Quick Reference.....	66
8.8	Layout and Surveying Procedures.....	66
8.9	Surveying of Bench Terraces and Preparatory Work.....	67
8.10	Topsoil Treatment or Preservation.....	68
8.11	Protection, Maintenance and Inspection.....	69
9	Grassed Waterways Design and Construction.....	71
9.1	Description.....	71
9.2	Objective of Waterways.....	71
9.3	Design Criteria and Requirements.....	71
9.4	Other Important Considerations.....	72
9.5	Sequence of Construction of Grassed Waterways.....	73
9.6	Design of Grassed Lined Waterways.....	73
9.7	Shape and Dimension of Waterways.....	74
9.8	Flow Velocity of Runoff Water.....	74
9.9	Capacity of a Waterway.....	76
9.10	Subsurface Drainage.....	77
9.11	Manning Roughness Coefficient.....	78
9.12	The n-VR Relationship in Channels Lined with Vegetation.....	78
9.13	Hydraulic Radius.....	79

9.14	General Design Approach.....	80
9.15	Waterway Construction Methods.....	81
9.16	Planning and Design of Grassed Waterway.....	81
9.17	Construction and Maintenance of Waterways.....	82
10	Flood Damage and its Prevention.....	84
10.1	Description.....	84
10.2	Adverse Effects of Storm Water.....	84
10.3	Stream Bank Erosion Protection.....	85
10.4	Stream Bank Protection with Gabion Check Dam.....	89
11	Design and Construction of Community Pond.....	92
11.1	Description.....	92
11.2	Selection of Pond Site.....	92
11.3	Layout of a Rectangular Hand-dug Pond.....	93
11.4	Pond Maintenance.....	93
11.5	Seepage Losses.....	94
11.6	Reducing Seepage and Evaporation Losses from a Pond.....	95
11.7	Calculating Capacity of a Farm Pond.....	95
12	Design and Construction of Earth Embankment Dam.....	100
12.1	Description.....	100
12.2	Components of Earth Dam.....	102
12.3	Design of Small Earth Dam.....	102
12.4	Construction of Small Earth Dams.....	102
12.5	Seepage Control and Safety against Internal Erosion.....	104
12.6	Spillway Design.....	105
12.7	Calculating Height and Storage Capacity of an Earth Dam.....	106
12.8	Reservoirs of a Dam.....	107
12.9	Factors Affecting Location for Reservoirs.....	107
11.10	Compaction of Soil for Embankment Dam.....	108
13	Design and Construction of Sand Storage Dams.....	110
13.1	Description.....	110
13.2	Basic Design Principles.....	111
13.3	Site Selection and Construction.....	112
13.4	Mechanisms to Collect Water from Sediment Storage Dams.....	114
13.5	Difference between Subsurface Dams and Sand Dams.....	115
14	Design and Construction of Storage and Diversion Dams.....	116
14.1	Description.....	116
14.2	Spillway as a Stream Return.....	118
14.3	Freeboard.....	119
14.4	Description of Diversion Dams.....	119
14.5	Spillway Design and Construction.....	120
14.6	Spillway Design Consideration.....	121

14.7	Energy Dissipater.....	121
15	Shallow Well Design and Construction.....	124
15.1	Overview.....	124
15.2	Description of Groundwater.....	125
15.3	Advantages and Limitations of Shallow Wells.....	126
15.4	Participation of Community in Site Selection.....	128
15.5	Preliminary Groundwater Survey.....	129
15.6	Methodology for Preliminary Hydrogeological Survey.....	130
15.7	Selection of Types of Wells and Construction Phases.....	131
15.8	Traditional and Permanent Wells.....	133
15.9	Advantages and Drawbacks.....	133
15.10	Technical Specifications for Well Construction.....	133
15.11	Construction of Head-wall, Apron, Drainage Channel and Cover Slab.....	134
15.12	Estimating the Water Yield of a Well.....	135
15.13	Cost and Maintenance Requirements.....	135
16	Spring Design and Construction.....	136
16.1	Description.....	136
16.2	Discharge Rate of Flow.....	138
16.3	Spring Water Protection.....	140
16.4	Benefits of Spring Development Structure.....	141
16.5	Basic Design Features.....	141
16.6	Designing the Structure.....	143
16.7	Selection of Site for Spring Construction.....	145
16.8	Preparing Site for Spring Construction.....	145
16.9	Spring Construction.....	146
16.10	Constructing the Spring Box.....	148
16.11	Installation of Spring Box.....	150
16.12	Alternatives to Spring Boxes.....	151
16.13	Operation and Maintenance.....	152
17	Design and Construction of Community Roads.....	154
17.1	Description.....	154
17.2	Basic Principles and Parameters in Design and Construction.....	155
17.3	Clearing of Ground for Feeder Road Alignment.....	158
17.4	Removal and Excavation of Topsoil for Feeder Road Construction.....	160
17.5	Earth Moving for Feeder Road Construction.....	161
17.6	Advantages and Phases of Feeder Road Construction.....	162
17.7	Compaction of Labour-based Feeder Road Construction.....	163
17.8	Drainage of Feeder Road.....	164
17.9	Roadside Drains for Community Road.....	167
17.10	Cross Drainage for Community Road.....	171
17.11	Gravelling of Labour-based Community Road.....	172

18	Methods of Compost Preparation.....	174
18.1	Description.....	174
18.2	Advantages.....	174
18.3	Processes of Decomposition.....	174
18.4	Process in Compost Preparation.....	175
18.5	Organic Material.....	176
18.6	Methods of Making Compost.....	176
18.7	Turning Over Compost Heap.....	177
18.8	Pit Compost Preparation.....	177
18.9	Trench Compost Preparation.....	178
18.10	Caring for Stored Compost.....	178
19	Development of Small Scale and Medium Scale Irrigation.....	179
19.1	Description.....	179
19.2	Irrigation Requirements.....	179
19.3	Designing Command Area.....	179
19.4	Water Losses through Irrigation Canal.....	180
19.5	Irrigation Canal Design.....	180
19.6	Design Discharge.....	181
19.7	Hydrologic Water Movement.....	182
19.8	Crop Water Requirements.....	183
19.9	Pan Evaporation Method.....	185
19.10	Determination of ETo, Using Pan Evaporation Method.....	188
20	Establishment of Nursery.....	190
20.1	Summary.....	190
20.2	Description of Establishing a Tree Nursery.....	190
20.3	Nursery Site Preparation.....	191
20.4	Nursery Operations.....	191
20.5	Seed Bed Preparation.....	192
21	Closed Area Management.....	202
21.1	Introduction.....	202
22.2	Definition of Closed Area Management.....	202
22.3	Principles of Closed Area Management.....	202
22.4	Approaches to Develop Closed Area Management Plan.....	204
22.5	Useful Procedures in Closing an Area.....	205
22	Provisional Work Norms and Technical Specifications for LIPWs.....	206
22.1	Description.....	206
	Glossary of Terms.....	220
	References.....	229

List of Figures and Diagrams

2.1 Wide spread serious gully erosion.....	18
2.2 Headword gully progress.....	20
2.3 Adverse effects of gully erosion.....	20
2.4 Key of gully check dam design and construction.....	21
2.5 Design spacing for gully check dam.....	22
2.6 Reshaping vertical and deep gully.....	23
2.7 Gully wall reshaping and planting with grasses.....	24
2.8 Design of diversion drain at gully head.....	24
2.9 Impact of gully check dams.....	25
2.10 Gully check dam spillway design.....	25
2.11 Check dam keyed into gully bed and in its walls.....	26
2.12 Cross section of key design at gully bed and bank.....	26
2.13 Gully key design at different depths.....	27
2.14 Apron and sill design.....	27
2.15 Spacing of gully check dams.....	27
2.16 Construction of stone filled gabion check dams.....	28
2.17 Brushwood gully check dams.....	29
2.18 Design of log check dam.....	30
3.1 Contour trench design and construction.....	31
3.2 Benefits of flood water harvesting.....	32
3.3 Design and construction of contour bunds.....	32
3.4 Design and construction of semi-circular bunds.....	33
3.5 Design and construction of staggered moisture harvesting contour trench.....	33
4.1 Design and construction of hillside terraces.....	35
4.2 Design and construction of hillside ditches.....	36
4.3 Spacing between hillside terraces.....	37
4.4 Design dimension for contour terraces.....	40
5.1 Rock catchment runoff water harvesting.....	42
5.2 Effective runoff water collection rock catchment in Kotido.....	43
5.3 Runoff water harvesting and storage area.....	43
5.4 Effective area for runoff water harvesting.....	44
5.5 Shallow depth and wide storage area leading to more evaporation losses in Napak.....	46
5.6 Potentials of in-situ moisture harvesting in moisture stress areas (arid & semi-arid areas).....	47
6.1 Typical and staggered runoff harvesting pits for effective moisture harvesting.....	50
6.2 Deep water harvesting contour trench for moisture stress area.....	50
6.3 Design and construction of zai pits.....	51
6.4 Staggered design and construction of zai pits.....	51
6.5 Effective moisture harvesting techniques.....	52
6.6 Planting position of seedlings in pits.....	53

7.1 Construction of basins.....	54
7.2 Staggered design of Negarims.....	54
7.3 Staggered design of V-shaped Negarims.....	55
7.4 Steps in laying out staggered Negarims.....	56
7.5 Design dimension for a small diversion dam.....	57
8.1 Cross section of a bench terrace.....	59
8.2 Design and construction of level bench terrace.....	60
8.3 Cross sectional view of a bench terrace.....	64
9.1 Cross-section of parabolic waterway.....	73
9.2 Configuration of a parabolic waterway.....	74
9.3 Configuration of a parabolic waterway.....	75
9.4 Formulae for dimensions relating to Trapezoidal, Triangular and Parabolic cross-sections.....	76
9.5 Spacing for tiled drain beneath a grass waterway.....	78
10.1 Flood damage in Kasese town.....	85
10.2 Flood damages and river bank erosion hazards.....	86
10.3 River bank collapse, caused by erosion, affects livelihoods of community.....	87
10.4 Different river bank erosion mitigation and protection strategies.....	88
10.5 River bank erosion control is effective with retaining walls.....	89
10.6 Design of stone filled rectangular gabion check dam.....	90
10.7 Gabion basket placed at river bend to prevent river bank erosion during flooding.....	91
11.1 Improved design and construction of rainwater harvesting pond (Kotido).....	93
11.2 Lay out and cross section of a pond.....	93
11.3 Sectional view of a rectangular pond with inlet and inner side embankment.....	94
11.4 Sectional top view and actual view of hand-dug circular pond.....	96
11.5 Sectional view of a circular pond.....	97
11.6 Sectional and top view of a rectangular pond.....	97
11.7 Calibrated calculation of volume of a pond using prismatic formula.....	98
11.8 Construction of steps to draw water from a pond.....	99
12.1 Typical View of zoned earth embankment dam.....	100
12.2 Sectional views of homogeneous earth embankment dam.....	100
12.3 Cross sectional views of zoned earth embankment dam.....	101
12.4 Typical cross section of a zoned earth fill dam.....	102
12.5 Typical zoned cross section of a zoned earth fill dam.....	102
12.6 Typical cross sectional views and sections of an earth fill dam.....	103
12.7 A typical seepage line for an earth fill dam.....	106
12.8 A typical top view or plan of a spillway	105
13.1 Typical storage dam (Kotido).....	110
13.2 Typical masonry sediment storage dam (Kotido).....	111
13.3 Lay out and construction sediment storage dam in arid and semi-arid areas.....	112
13.4 Construction stages for sediment storage dam.....	113
13.5 Extraction of water from sand dams.....	114

13.6 Extraction of water from sand dams through an outlet pipe.....	114
14.1 Properly managed dam is vital to secure water sources (Kotido).....	116
14.2 Monthly outflow and inflow water measurement.....	117
14.3 Good overflow spillway masonry dam.....	120
14.4 Front view of an overflow masonry diversion dam.....	121
14.5 Cross sectional view of an overflow spillway.....	122
14.6 Stilling basin and energy dissipaters of overflow dams.....	122
15.1 Types of aquifers and possible locations or sites of well locations.....	124
15.2 Simple and local hand dug well construction technique.....	126
15.3 Hand dug well with a firmly sealed cap.....	127
15.4 Manual methods to draw out water from hand dug wells.....	128
15.5 Manual hand dug well construction.....	129
15.6 Shallow well with proper area drainage system	130
15.7 Profile and sectional view of a hand dug shallow well.....	131
15.8 Cross section and profile of a dug well.....	134
16.1 Profile of a confined aquifer and emergence of a spring.....	136
16.2 Formation of Artesian spring.....	137
16.3 Hydrological formation and aquifer emergence of a spring.....	137
16.4 Formation point of a gravity spring.....	138
16.5 Measurement of discharge through a 90° V notch.....	139
16.6 Spring box with tight cover to measure volume of discharge.....	139
16.7 Spring box construction with tight cover.....	141
16.8 Typical spring, plan view (not to scale).....	142
16.9 Spring box with permeable bottom for collecting spring water from an open level ground.....	143
16.10 Typical spring construction with over-lapping tight cover.....	144
16.11 Dimensional plans of pervious side spring box & pervious bottom spring box.....	144
16.12 Preparation of spring box site.....	146
16.13 Form for a permeable-bottom spring box.....	149
16.14 Spring box with single pervious side for hillside collection.....	150
16.15 Seeps and spring intake with collection pipes.....	151
16.16 Spring construction with horizontal well placement.....	152
17.1 Section view for laying out sharp curves.....	156
17.2 Cross section of cut and fill of earthworks.....	157
17.3 Alignment of a road on rugged terrain.....	157
17.4 Lateral view of a road layout on a rugged terrain.....	158
17.5 Tree cutting system.....	159
17.6 Cross section and profile for cut and fill (earthwork).....	161
17.7 Phases of community road construction	163
17.8 Compaction of a road with a roller.....	163
17.9 Excavating and spreading of soil on road surface.....	164
17.10 Labour intensive road construction on flat and rolling terrain (stable soil).....	165

17.11 Labour intensive road construction on steep terrain (stable soil).....	166
17.12 Graveled community road on flat and rolling terrain (sandy & weak soil).....	168
17.13 Graveled community road on steep terrain (weak soil).....	168
17.14 Graveled community road on flat & rolling terrain (black soil).....	170
17.15 Cross sectional view of a culvert.....	171
18.1 Important micro-organisms for decomposition.....	175
18.2 Layering of materials for compost preparation.....	176
18.3 Compost heap preparation.....	176
18.4 Compost pits preparation.....	177
19.1 Typical cross section of an unlined earthen canal.....	181
19.2 Hydrologic cycle of water in different phases.....	183
19.3 Climatic factors influencing evapotranspiration(ETo).....	184
19.4 Growth stages of crops.....	184
19.5 Methods to determine reference crop.....	185
19.6 Calculation of crop water.....	185
19.7 Pan Evaporation Method.....	186
19.8 Adding water when water depth in the pan drops too.....	186
19.9 Sunken Colorado Evaporation Pan.....	187
19.10 Class A Evaporation Pan.....	187
20.1 Integrated seedling nursery management.....	191
20.2 Potted seedling production.....	193
20.3 An example of a sunken bed filling made form raised bed bricks with a mix of soil and manure.....	193
20.4 Cover the nursery with dry grass or maize stalk then water.....	195
20.5 Transferring/pricking young & tender seedlings from seedbeds into containers (pots).....	196
20.6 Watering using a simple tin with holes at the bottom.....	196
20.7 Root pruning using a knife.....	197
20.8 Hardening off seedlings.....	198

Chapter 1

Background And Justification

1.1 Introduction to the Technical Design Manual

The technical design manual has been prepared to provide basic and practical information for field experts, field supervisors and development extension workers on technical specifications and norms that are required to undertake various labour intensive public works related to soil and water conservation, water harvesting, environmental rehabilitation, basic community infrastructure and services. The main purpose of this technical manual is to guide field-staff on the implementation of technical standards with respect to local conditions such as topography, soil type, landscape, vegetation cover and other design parameters.

The technical manual has attempted to summarize key and relevant techniques and technologies that can provide information and guidance for technical staff on key design and implementation requirements of labour intensive public works. It further summarizes the common techniques and technologies commonly applied in labour intensive public works, which can be used within the context of Public Work Programme Guidelines. The manual has basically been prepared based on the experiences and lessons learned from ongoing labour intensive public works in Uganda, particularly in Karamoja. To make the manual more flexible and open to further accommodate various local conditions and agro-ecological situations, possible efforts have been attempted. It has also been brief and more descriptive to envision and exploit additional techniques for a set of labour intensive public works that might have not been captured, but are proven to be successful and adaptable to the specific local conditions.

It is anticipated that to achieve optimum development objectives of Labor Intensive Public Works (LIPW), implementation of subprojects will also follow appropriate technical standards and specifications within the natural boundaries of a given watershed. For example, stabilization of physical soil and water conservation structures with biological measures, integration of different and interlinked physical structures and technologies (such as storm water drains with natural or artificial water-waterways), appropriate design and implementation of moisture conservation structures, safe flood disposal structures, water works, etc. The technical manual has attempted to refer to techniques and technologies for Public Work Programme (PWP) that have commonly been implemented by government organizations, non-governmental organizations and other key development partners.

Based on local circumstances, design elements, technical standards and specifications, the manual can be further modified and improved by districts and development partners. It has also been envisaged that though concerted efforts have been made, application of these techniques and technologies should still be refined by the subject matter specialists and extension workers.

1.2 Rationale for the Technical Design Manual

The main objective of preparing this technical manual is to guide the field staff to follow minimum technical standards and specifications for the planning and implementation of LIPWs with respect to local conditions such as soils type, landscape, rainfall patterns, working culture, climatic conditions and other required parameters.

This technical manual has also been designed to equip field staff with a minimum practical information on design specifications and technical standards that are necessary to undertake various labour intensive public works such as integrated watershed management, water harvesting, soil and water conservation, storm water drain measures, runoff water harvesting.

1.3 Technologies for Labour Intensive Public Works (LIPW)

As most of the labour intensive public work components include soil and water conservation, water harvesting, small scale irrigation, water supply schemes, afforestation, storm water control, small scale rural infrastructure and other basic social services, the design and implementation of this technical manual has tried to address appropriate environmental and socio-economic parameters of the agro-ecological conditions. With this regard, selection of technologies for labour intensive public works will focus on districts or areas considered at a risk of rapidly losing their natural resources and agriculture potentials caused by high land degradation rates, climate change and other multifaceted effects. The technical manual on labour intensive public works is, therefore, designed to be as simple and practical as possible so that the field staff and practitioners can plan, implement and ensure active participation of the whole community during the planning and implementation processes. Where there are not enough and trained district experts to arrange and organize capacity development for the implementation of labour intensive public works, provision of technical training, that can be cascaded down up to community level, for the existing field staff will be fundamental to be considered by MGLSD and relevant stakeholders.

1.4 Identification and Prioritization of Techniques and Technologies

After gathering considerable information from local community, key informants, focal points, community planning teams, fieldsurveys, and mapping exercise on the constraints of the community and the potential opportunities of labour intensive public works, appropriate labour intensive public works should be designed and implemented following the optimum technical standards and quality criteria. Poor quality labour intensive public works and inappropriate selection of technologies don't generate sustainable results; they may instead cause adverse environmental effects, mistrust among communities, impair the spirits and mindset up of communities towards further development.

To select appropriate techniques and technologies from a pool of different labour intensive public works, the district and public work experts should carefully identify those technologies that are demand-driven, priorities of communities and are most suitable and adaptable under different agro-ecological conditions. In implementing labour intensive public works, the extension workers and community facilitators will have to notice that for common problems of households or communities, it is easy to reach agreement on types of techniques and technologies that should be implemented but there wouldn't be any compromise on the quality, adaptability and sustainability of these interventions. For example, the problem of water shortage can be compromised by constructing a demand-driven pond or developing a spring. However, spring development may be possible only if its flow is sufficient and groundwater table is rechargeable, and its safety from water-borne disease is assured. Similarly, a long-serving community pond can be constructed if and only if sedimentation and contamination is controlled through the treatment and rehabilitation of its catchment area. Therefore, the successful implementation of such labour intensive public work subprojects depends on integrated watershed management principles and practices where the technologies and socio-economic factors are considered. As the design and implementation of physical soil and water conservation and other infrastructure components cannot be disconnected, sequencing of labour intensive public works will also be crucial.

Subsequently, not all land users and communities have the same level of capacity and capability to implement labour intensive public works, it is therefore important supporting those households who cannot meet the labor requirements needed to cover their share of work, which is based on the standard work norms and technical specifications of these technologies.

1.5 Basic Social Infrastructure Services

Though the basic social infrastructure services are well suited and important components of the Labour Intensive Public Works (LIPWs), their design and specification is not included in this technical manual. However, as the respective social infrastructure sectors such as health, education, may follow their technical standards and norms, the design and implementation of the labour intensive public work subprojects will follow the existing technical standards of the respective sectors. Therefore, to design and implement labour intensive public work subprojects the relevant sector institutions will explicitly follow their technical standards and work norms.

1.6 Key Integration and Sequencing of Technologies

Despite many techniques and technologies having their specific design elements and features, their implementation and management in a given watershed and land-use systems should be in tandem with one another. In order to improve the effectiveness and sustainability of LIPW, integration of technologies needs to be considered. Thus, logical sequencing and integration of different labour intensive public works will result in considerable impacts when they are integrated rather than implemented in isolation.

1.7 Technical Skill Requirement

This technical manual presents different techniques and technologies that are appropriate for LIPW in Uganda and anywhere else. The techniques and technologies enumerated in this manual are fundamental instruments to plan and implement LIPWs. However, the technical capacity gap of government staff, key development partners and communities may be one of the major challenges in planning and implementing good quality and successful labour intensive public works. Therefore, technical training is very critical to help and equip the field staff with the necessary skills and knowledge to plan and implement quality oriented and successful LIPWs. Thus, technical training on these techniques and technologies can be aimed at providing targeted skill improvement training to staff who are accountable to plan and implement LIPW subprojects.

To effect this technical training for the implementation of successful LIPWs, MGLSD would coordinate and liaise with relevant stakeholders to develop key training requirements, such as capacity gap and training needs assessment, recruitment of trainers and trainees, supporting preparation of simplified training modules, training materials, coordination of training and facilities, monitoring of the training, evaluating impact of the training, etc.

1.8 Training Phases and Minimum Level of Education

The main purpose of this technical training is to provide basic technical skills and knowledge sharing for technical staff on techniques and technologies for LIPWs. This technical training will also oversee clear and explicit understanding on roles and responsibilities of different stakeholders to plan and implement

LIPWs. To conduct this technical training at different levels, MGLSD may adopt training of trainers (TOT) approaches that can be organized and conveyed in three phases.

The first phase of this technical training will be conducted as TOT for selected technical experts and staff of line ministries, districts, development partners and NGOs at the national level. The training participants (trainees) for this first phase TOT will be the technical staff who have basic technical background and expertise directly engaged in providing technical support to field staff in the design and implementation of LIPWs. It is recommended that the staff who will be recruited for the first phase of this TOT should at least be diploma graduates who have technical background and expertise on soil and water conservation, forestry, water works construction, water harvesting, basic social infrastructure and other related fields.

In the second phase of the training, the trainers who received the TOT training in the first phase at national level will organize a cascaded type of similar training for respective district and sub county technical staff and parish extension workers who are or will be engaged in the actual planning and implementation of LIPWs.

In the third phase of the training, user-friendly training modules will be prepared in a simplified way and provided to community leaders, community planning teams, and community organizations who will be engaged in the day-to-day implementation and monitoring of LIPWs. The community level training in this phase will focus more on-the-job training and practical field exercise that will give “do-it-yourself” abilities to individual farmers, communities and community organizations.

Chapter 2

Design and Construction Of Gully Control Measures

2.1 Description

Gully erosion is defined as a channel cut by concentrated runoff water through which water commonly flows only during and immediately after heavy rains. A gully may be branching or it may be linear, rather long, narrow, and of uniform width. Though it is often difficult to differentiate between large gullies and small river valleys, gullies have intermittent storm water flows of shorter duration compared to rivers with seasonal flows. Gully erosion is geographically a widespread problem and is the worst stage of soil erosion, which is common and serious in semi-arid regions, characterized by denuded landscape and flash floods. Gully erosion is more difficult and expensive to control than sheet and rill erosions, and is also more spectacular than inter-rill erosion. Contrary to sheet and rill erosion, the damage caused to land by gully erosion is permanent (see Fig 2.1). Gully erosion produces channels larger than rills and is an advanced stage of rill erosion much as rill erosion is an advanced stage of sheet erosion. Gullies are cutouts restricted to easily erodible soils.

2.2 Causes of Gully Erosion

Gully erosion is a serious problem in the productive agricultural lands, forest lands, range lands, which decreases the size of these agricultural lands, forest lands, and grazing lands. Gullies deliver large amounts of sediment deposits to productive agricultural lands, range lands, irrigation channels, roads and communication systems. Gully erosion starts with the breakdown of a state of meta-stable equilibrium in a stream or water courses. In its initial stage, gully formation is caused by the runoff water first collected in surface depressions and later flowing at a velocity sufficient to carry away the soil particles. Under some natural conditions of rolling topography (concave slopes) and soils with loose structure and fine texture, the processes of soil particle detachment and transportation are accelerated. Most gullies are formed due to the neglect in the initial stages and simple steps taken at the appropriate time can prevent the formation, extension and enlargement of gullies.



Fig 2.1 Wide spread gully erosion

Some of the common causes of gully formation include:

- Improper land use resulting in increased proportion of cultivated land over natural forests, and shrubs or range lands.
- Excessive clearing of natural covers such as trees, shrubs, and grasses through cutting or burning (heavily burnt soils lose their structure and become susceptible to erosion).
- Poor farming practices such as up-and-down or along the slope cultivation on steep slopes, cultivation across contours, and lack of improved agronomic practices (like crop rotations, cover crops strip cropping, and mulching).
- Excessive grazing leading to the destruction of vegetables by livestock and detachment of soils by animal tramping on grazing lands.
- Improperly located and unprotected roads, farm access tracks and trails.
- Excess runoff resulting from roads, improperly designed and placed road drainage structures and unprotected banks.
- Unprotected and poorly designed conservation structures, such as soil bunds, terraces, waterways, and diversions. For example, unmaintained breaks in the soil bunds or terraces accumulate excess runoff and take away the whole series of structures causing severe gully formation.
- Excavated hillside drains or diversions or query pits without needed vegetative or structural protection.

It is, therefore, important that the soil and water conservation field supervisors and technicians acquaint themselves with the important causes of gully formation and the natural, physical and biological conditions that are likely to start gulling. This will help them suggest land use adjustment, cultural and other measures for the prevention and control of gullies.

2.3 Principles of Gully Control

Since gullies are formed due to high runoff volume and peak runoff rate, minimizing the runoff volume and peak runoff rate through improved land use system is essential in gully control. The fundamental gully control measures are therefore:

1. Improvement of gully catchments to reduce and regulate the runoff volume and peak runoff rates;
2. Diversion of excess runoff water upstream of the gully area or at the gully head; and
3. Stabilization of gullies by structural measures, accompanied by vegetative measures.

In some geographical areas, the above first and/or second methods may be sufficient to stabilize the incipient or small gullies while in tropical and subtropical regions, which receive large rains, all three methods may have to be used for successful gully control. Controlling gully erosion can be an elusive process. The rate of success in such schemes depends on the planning, design and techniques employed. The ultimate success depends upon the proper diagnosis of the problem, steps taken to eliminate the causes, and drastic changes in land use to stabilize the ecosystem. Some gully control measures are extremely expensive, and resource-poor farmers or communities cannot afford to invest on them.

2.4 Main Processes of Gully Formation

Mechanics of gully erosion can be reduced to three main components: (1) head-cut; (2) gully bed erosion; and (3) bank erosion or lateral erosion. While the head-cut results in the extension of a gully towards its head (see Fig 2.2 and Fig 2.3), bed erosion and bank erosion result in deepening and widening of the gullies.

Thus, the effective gully control must aim at stabilization of the channel gradient, channel head-cut and slumping gully walls. Uncontrolled surface runoff containing suspended sediments create cuts, shallow rills or micro-channels ranging from few millimeters up to ten centimeters in depth.

These narrow rills collect high velocity run-off, erode the soil in the micro-channels, resulting in a sudden difference in the channel grade at the head of the rills.

This accelerates further erosion and deepening of rills into gullies. Widening, deepening and head extension of a gully continues till the stage of meta-stable equilibrium is reached again.

As the gully extends, lateral gullies branch out from the incoming drainage lines and sediment occurs at the gully outlet. Technically speaking, gully development takes place at the following critical locations:

- Head-cut: due to water directly eroding the gully head.
- Bed erosion: water flowing in steeply graded channel and unprotected gully bed eroding the gully bed.
- Sliding or mass movement: resulting from under cutting of walls due to high velocity of water flow.
- Freezing and thawing of exposed soils: erodes the gully walls.

The main damages caused by gully erosion include (a) land damage (gullies often dissect the fertile agricultural and rangelands, taking a heavy toll of the land); (b) declining effect on land productivity (in addition to the loss of land due to gully formation, the undamaged land adjacent to the gullies suffers from declining productivity); and (c) sediment damage (gullies, landslides and other critically eroded areas leading to heavy loss of soils).

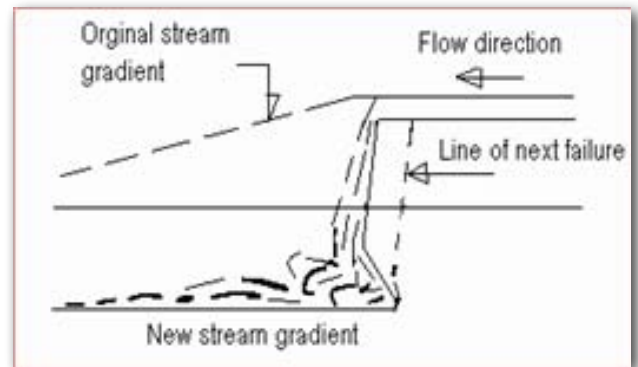

Fig 2.2 Headward gully progress



Fig 2.3 Adverse effects of gully erosion

2.5 Basic Gully Control Design and Construction Principles

The size and shape of a drainage area as well as the length and gradient of its slope has an effect on the runoff rate and amount of surface water. Therefore, all topographic characteristics should be studied in detail before gully-plugging work begins. here are several designs how gully control and construction structures should be constructed.

The kind of gully control measures that should be constructed depends on the local situation. In gully control, structural measures such as loose stone and boulder check dams, brushwood check dams, gabion check dams, log check dams are used to facilitate the growth of permanent vegetative covers. Check dams are constructed across the gully bed to stop channel and lateral erosion.

By reducing the original gradient of the gully channel, check dams diminish the velocity of water flow and the erosive power of run-off. The objective of the design of gully erosion control should be to build the most economical structure. In the design and construction of gully erosion control structures, the following basic design criteria should be kept in mind:

- The check dam should be properly keyed across its base and up the abutment to the crest elevation (see Fig 2.4).
- An adequate spillway should be provided for safe disposal of runoff. The sides of the check dam must be higher than the center so that water is always directed over the center of the dam. This avoids the check dam being outflanked by the flow.
- An apron of non-erodible material should be provided at the base to dissipate the energy of later falling through the spillway.
- Proper spacing between the successive dams should be ensured.
- The height of the dam should be properly planned.
- The gully banks at the downstream should be properly protected from the splash erosion.
- The construction material should be of a good quality.

A gully treatment plan should be prepared not only for the treatment of the gully but also for the watershed area of the gully. A gully treatment plan should include the treatment of agricultural lands, rangelands and forestlands in the gully catchment. Gully treatment packages should also be accompanied by other soil and water conservation practices such as contour bunds, terraces, diversion drains, grass waterways, sediment storage dams, detention dams and re-vegetation of critical watersheds. These measures may either be used alone or in combination with other conservation practices.

The primary objectives of gully control measures are to accomplish:

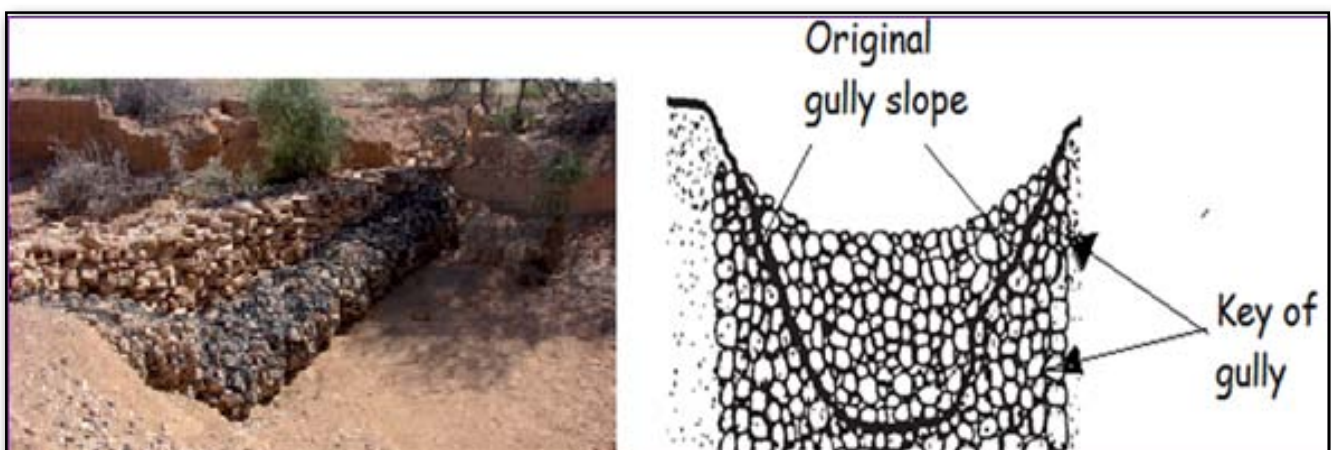

Fig 2.4 Key of gully check dam design and construction

- * Maximum retention of rainfall runoff on the watershed (by using proper soil conservation and management practices on farmlands, rangelands and forest lands).

- * Interception and diversion of runoff above the gully area with the diversion drain. It should however, be remembered that the diverted water must be directed to well-stabilized natural channels or specially built waterways.
- * Revegetation, either naturally or through planting.
- * Construction of grade stabilization structures to control the channel erosion and encourage sedimentation behind the structure.
- * Exclusion of all kinds of grazing.
- * Filling and shaping/reshaping. This is very expensive and not economical except for gullies that endanger the cultivated lands. However, such very deep and vertical gullies can be reshaped and sodded or planted with grasses or tree planting that may easily stabilize the gully and also makes use of the wasted land.

For the control of gullies, as for all other problems related to land degradation due to soil erosion, prevention is better than cure. If proper land use, soil management and conservation practices are followed early enough in the watersheds, soil erosion and gully formation can be prevented. Such early prevention can save time and money, but as the gully becomes larger, it becomes more expensive and difficult to control. The gully control measures will also depend upon the size of the gully.

Based on the gully depth and the drainage area, gullies may be classified as:

- * Small: less than 3 m deep with drainage area less than 20 ha.
- * Medium: 3 to 5 m deep with drainage area from 20 to 30 ha.
- * Large: more than 5 m deep with a drainage area more than 60 ha.

Various gully control measures can be generally classified into structural or physical measures, and vegetative or biological measures. For an effective gully control programme, vegetative and structural measures should supplement each other. However, if the growing conditions are not suitable due to harsh conditions, structural measures are necessary. Additionally, structural measures are necessary for treatment of critical locations, like head-cuts, entrances of branch gullies and at places where abrupt changes in the gradient occur.

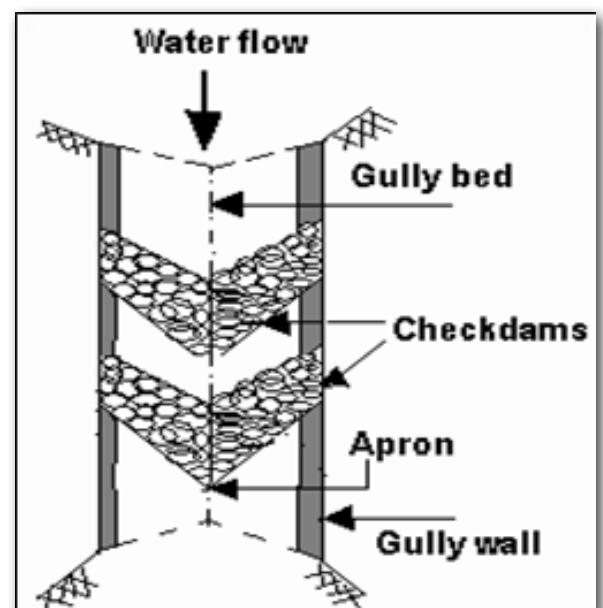

Fig 2.5 Design spacing for gully check dam

2.6 Structural Gully Control Measures

Practically speaking, medium and large gullies cannot be controlled by vegetation alone or by only diverting the runoff. A careful study should be made to ascertain where these vegetative control measures have to be supplemented with the structural measures. The structural measures should be used only when the other measures are not applicable or adequate. The size and cost of structures required to control a gully will vary according to the size of the gully and its stage of development. Protection structures for gully control are required for reducing and stabilizing the channel gradient so that the water can flow at no erosive velocity.

2.7 Filling and Shaping of Gullies

Filling and shaping (or reshaping) of gullies is applicable only for small and discontinuous gullies in their early stage of development, but for the large gullies this method is very expensive and not economically feasible. When the structural method of treatment is used, the gullied area is shaped and made smooth so that the vegetation can be established over the area or even be restored to farming and for other economic benefits. During the filling process, the soil should be well compacted with shovels or trampling. The filling operation should be done or complete just before the start of rains. In many cases, it is more practical to completely reshape very severely eroded gully areas which typically have numerous crumbling and dried out vertical walls, and its entire work of reshaping and filling should be done in one operation. Piecemeal filling and shaping can result in increased erosion due to over falls. Deep and steep slope gullies are difficult to rehabilitate even with gabions in place without reshaping or shaping (see Fig 2.6, Fig 2.7).



Fig 2.6 Reshaping vertical and deep gully

Reshaping of such deep and vertical gullies provides a gentler slope on which plants can grow. After reshaping, many plants or bushes removed before “shaping” can later be replanted or sodded on the new surface and the soil of the entirely treated area can be rehabilitated with a protective mulch layer which will improve rainwater infiltration.

The topsoil of gullies should be stockpiled and re-spread over exposed surface areas to ensure rapid establishment of vegetation.

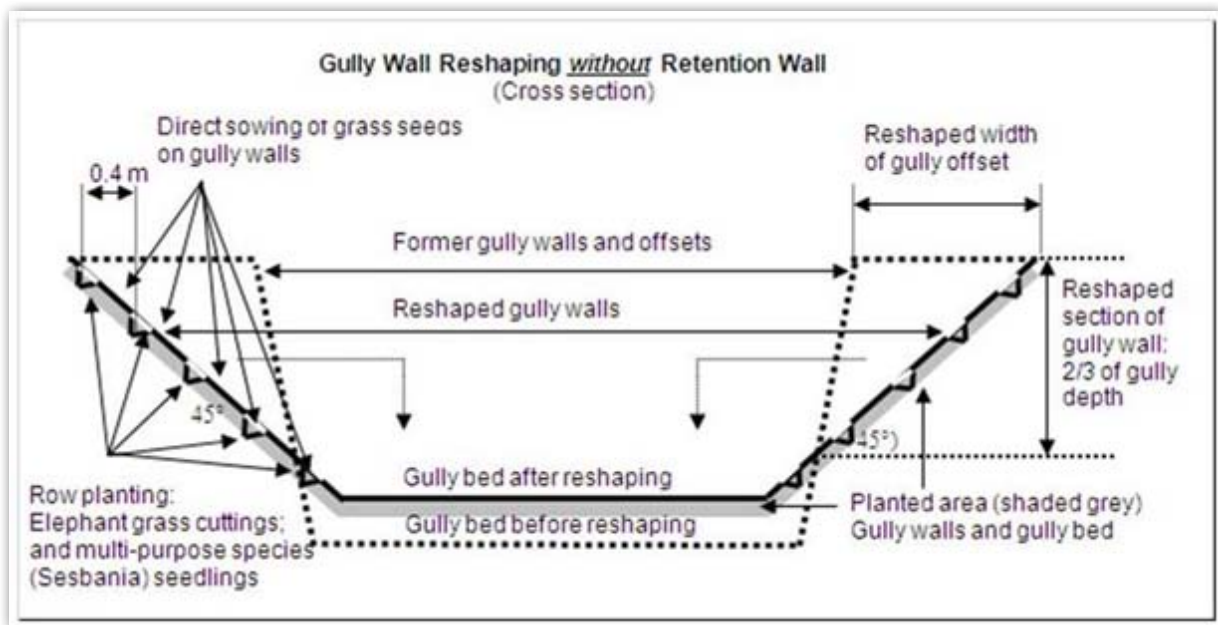

Fig 2.7 Gully wall reshaping and planting with grasses

Sodding of grasses can be used to provide a quick cover and rehabilitation of the reshaped gully surface. During the filling and shaping process the soil should be well compacted, filling operation should be done before the rains, close growing plants or grasses should be planted or seeded immediately to protect the gully from erosion, and the entire work of reshaping and filling should be done in one operation, before next rain season.

2.8 Temporary Diversion and Retention of Excess Water-flow

Temporary diversion of water off the gully head during the initial period of establishment of vegetation is necessary. The temporary disposal of the diverted water should be disposed to the safe outlet without causing any erosion problems. But, when it is not possible to dispose of the diverted water safely to stabilized channels or other safe outlets, it is advisable not to divert the water.

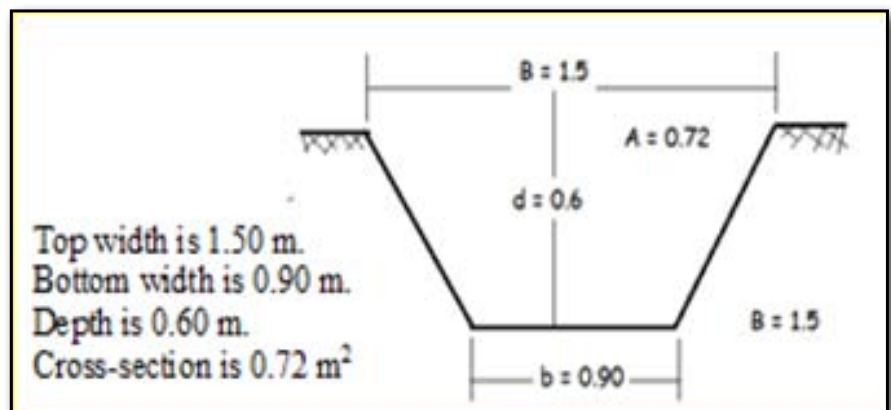

Fig 2.8 Design of diversion drain at gully head

Diversions should be located away from the gully edges, at a distance equal to at least three times the gully depth. Locating diversions closer to the gully edge will endanger the gully due to the extension of the head-cut. Headward extension of small gullies on the grazing lands can be controlled by building temporary eyebrow shaped ridges of excavated earth above the gully head. The ends of the ridge should lead downslope to good grass covered area. Diversion drains should not generally exceed 400 meters in length and its gradient should not exceed one percent (1%). In general terms, a hand dug diversion drain for a small catchment area should have the above dimensions (see Fig 2.8).

2.9 Gully Check-dams as Gully Control Measures

A check dam is a structure constructed of stones, brushwood, gabions, gully plugs, gravel-filled sandbags or combination of these used for gully control. A properly designed and constructed check dam acts as a detention dam, retention dam and a drop structure. A check dam, even after it is filled with sediment, will still function as a detention dam or drop structure.

According to their functions, check dams can be classified as rock fill or loose rock check dams, gabion check dams, brush wood check-dam, retention dams, detention dams, log check dams, sediment storage dams, etc. A rock fill or loose rock is a type of dam built with loose stones and is most commonly used engineering structure in gully control. These dams being porous, release part of flow through the structure, thereby decreasing the head of the flow over the spillway. Loose stone check dams, made of relatively small rocks, are placed across the gully and their main objectives are to control channel erosion along the gully bed and to stop waterfall erosion by stabilizing the gully bed as well as the head of the gully.

Loose stone check dams are used to stabilize the incipient and small gullies and the branch gullies of a continuous gully or gully network. The length of the gully channel is not more than 100 meters and the gully catchment area is preferably two hectares or less. The rocks or stones should be a hard material that will not easily be moved with water flow. Materials like shale and sandstone, which can be washed away by the moving flood water, should be avoided for the construction of rock check dams.

The purpose of appropriate design of check dams should be to build the most economical structure. The following design criteria should be reiterated and kept in mind when considering the design of gully constructions:

- * The dam should be properly keyed across its base and up the abutment to the crest elevation;
- * An adequate spillway should be provided for safe disposal of runoff (see Fig 2.10);
- * An apron of non-erodible material should be provided at the base to dissipate the energy of water falling through the spillway;
- * Proper spacing between the successive dams should be ensured;
- * The height of the dam should be properly planned;
- * The gully banks at the downstream should be properly protected from the splash erosion;
- * The construction material should be of a good quality.



Fig 2.9 Impacts of gully check dams

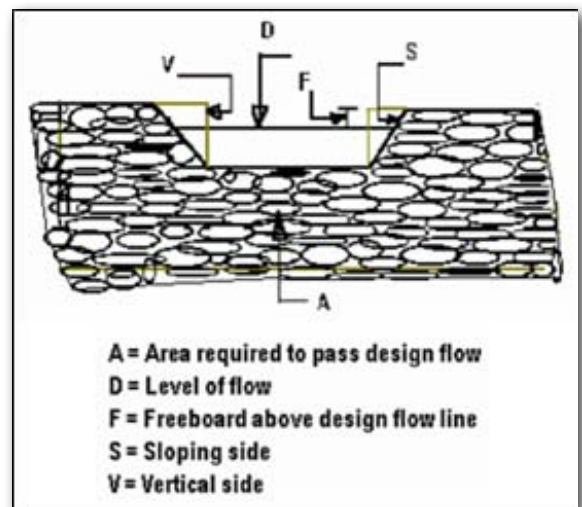

Fig 2.10 Gully check dam spillway design

2.10 Design of Key for Check-dam

A trench key of 50 to 100 cm deep should be constructed into the bed and walls of the gully at both sides (see Fig 2.11). While digging the trench, its reverse gradient should be 10%. The trench should extend into both abutments up to 100 cm, reaching up to the crest level of the check. The width of the key trench should be 100 cm to 150 cm, depending upon the width of the dam wall. The key trench should be first filled with stones, and the stones used for the check dams should be angular if possible since the stones can interlock easily and form a denser structure. The voids or spaces between the stones should be filled with smaller and hand placed stones. If smaller stones are to be used for the dam, they should be placed in the centre and the outer surface covered with large stones.

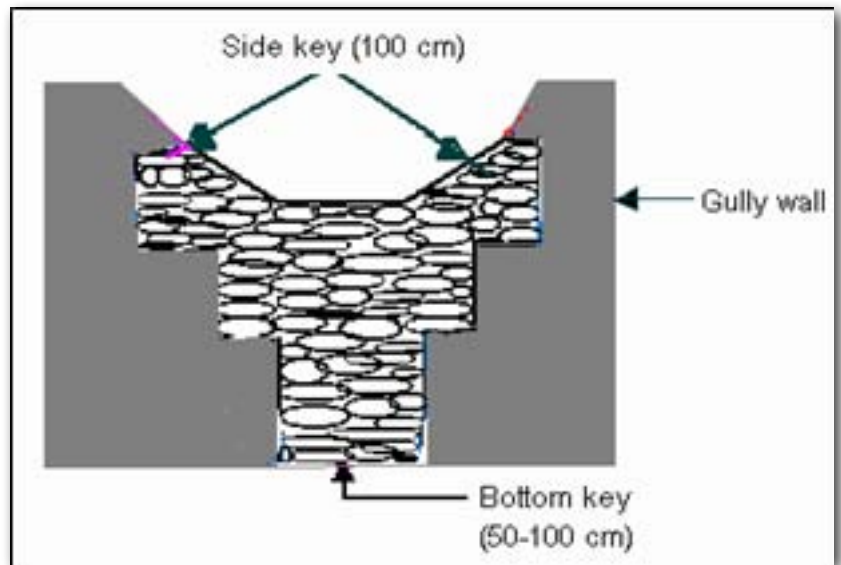

Fig 2.11 Check dam keyed into bed & its walls (abutments)

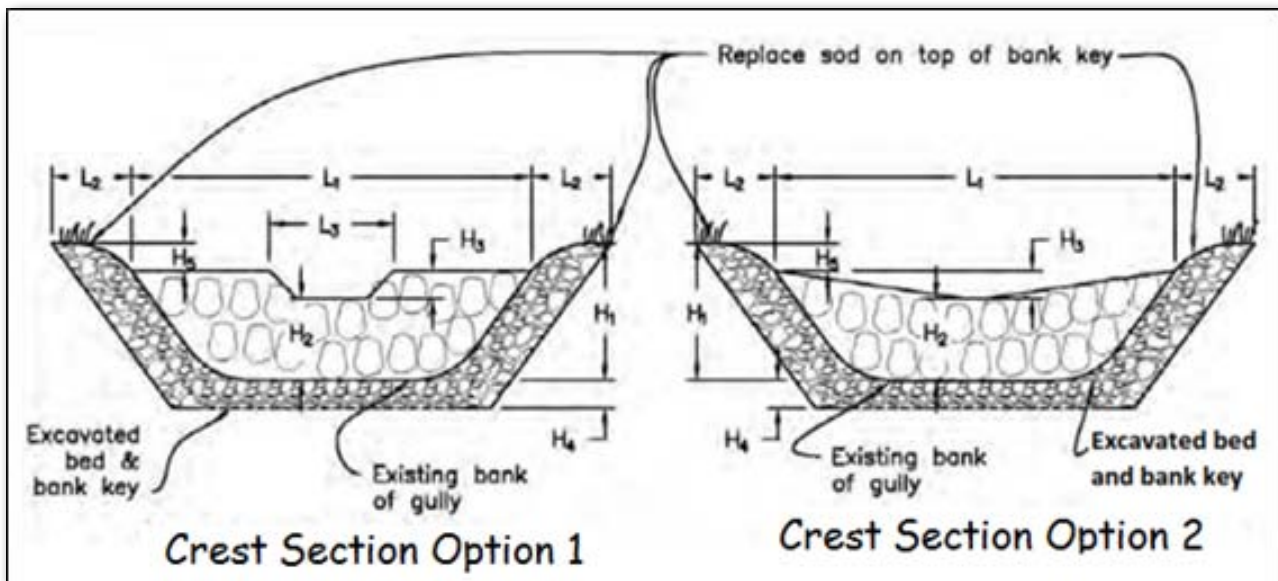

Fig 2.12 Cross section of a check dam key design at the gully bed and bank (abutment)

The stones on the bank and apron should be placed on a 20 cm filter layer of crushed stones to prevent displacement of underlying soil. After filling the key trench up to the ground level with hard stones, the construction of the body of the dam begins. The bottom, middle and top width of the dam should be properly designed. As a rule of thumb, the bottom width of the dam should be 0.6 times the height of the dam, while the mid and top width should be 0.5 and 0.4 times the height, respectively (see Fig 2.13). A proper spillway should be constructed on all the check dams. This spillway should be designed to pass the expected maximum flow without overtopping the check dam.

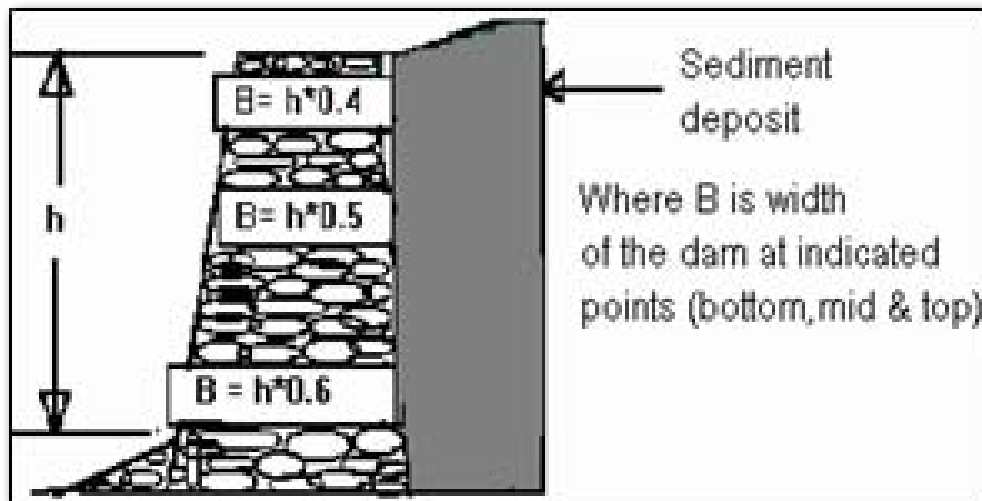

Fig 2.13 Gully key design at different depths

The spillway must be big enough to take the maximum expected flow once in ten years. For an accurate estimation of peak flow on rainfall runoff relationship is necessary to obtain. However, for a rough estimation of peak flow, the water marks visible on the gully banks or the debris deposits give a good indication of the magnitude of peak flow and the dimension required for the spillway.

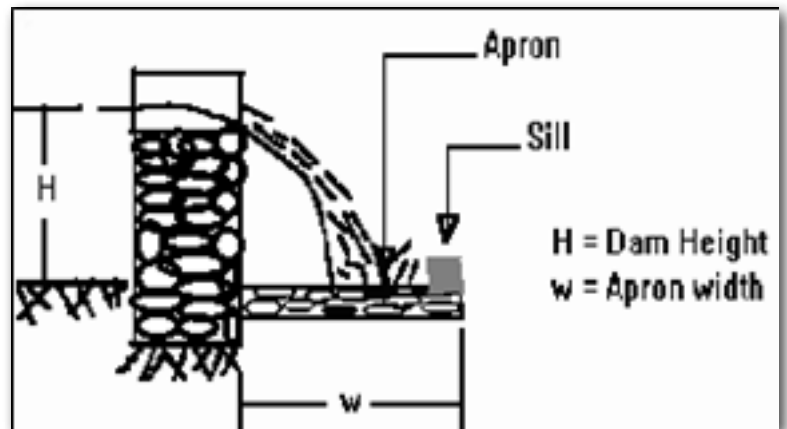

Fig 2.14 Apron & sill design

A free board of at least 25 cm should always be provided. The energy of the waterfall increases with the depth of the flow. Therefore, a spillway with greater length relative to the depth is more desirable.

Different shapes of spillways can be used, such as curved, rectangular, triangular or trapezoidal. But, a rectangular spillway cross section is simple and most commonly used for small check dams. The spillways should be placed in the center of the dam (see Fig 2.12). The flow capacity of the check dam can be increased by giving the dam crest slope toward the banks. This will direct the flow at the ground surface and it may extend up to a distance equal to half the height of the waterfall. A sill about 15 cm high should be constructed on the lower end of the apron (see Fig 2.14).

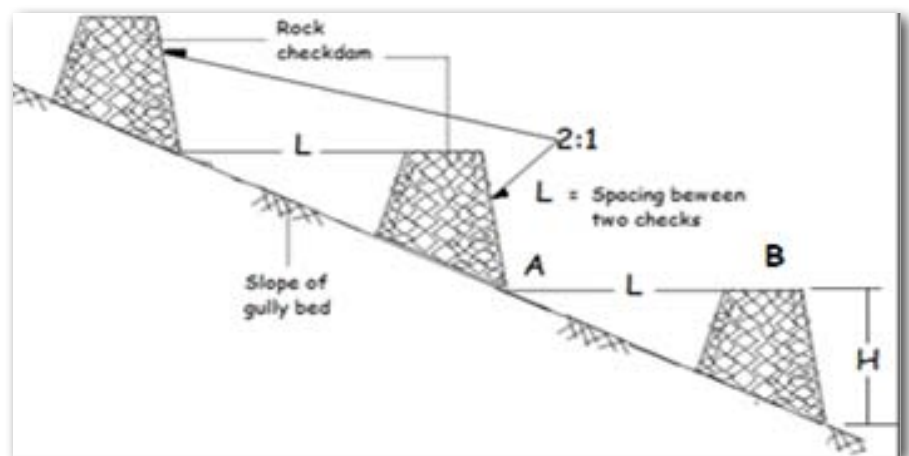

Fig 2.15 Spacing of gully check dams

2.11 Spacing of Check Dams

The gradient of sediment deposits in a single dam, being gentler than the gully bed gradient, a scarp will develop which is like a gully hatched, will advance upstream increasing the gully width and depth. Check dams, therefore, should be installed in systems starting from the mouth of the gully upstream. The number of check dams will increase with the increasing gully gradient. However, for a given gully gradient, as the height of the check dam increases, their number will decrease. If the objective of the gully check dams is to trap maximum amount of sediment, then higher and wider spaced check dams should be built. If, however, the objective is to stabilize the gully gradient, a series of small and closely spaced check dams should be built. The best spacing for gully check dams is when the elevation of the toe of the higher check dam is the same as the bottom of the spillway of the lower check dam (see Fig 2.15).

- ◆ H = effective height of the dam (from toe to top of the spillway).
- ◆ L = sufficient distance between points A and B. The two dams, point A and B have the same elevation. The following rule of thumb may be used to compute the spacing between the check dams.
- ◆ $L = 1.7H/G$. Where, L = spacing in meters; H = effective height of the check dam (height between spillway bottom to gully bottom); and G = gully gradient in decimal.

The height of check dams depends upon the objective of gully treatment. The water or runoff passing through the spillway should not be allowed to splash from the apron against the banks. If the banks of the gully are steep, they should first be slightly reshaped or graded and stone protection must be placed on the face of the gully.

2.12 Gabion Check Dams

A gabion check dam consists of galvanized iron steel wire cages, usually 2 m x 1 m x 1 m (= 2 m³) size, filled with loose rocks. The cages are placed close together and tightly tied with wire. The stepped placement of gabions allows greater stability of the dam to withstand the impounded water pressure.

In constructing check dams, locally available and appropriate materials should be preferred. The stones to use for filling the gabions should be hard and sufficient size. The stones should be placed tightly together so that no large voids are created. If there are large voids, the stones get realigned when the water flows through the dam. This may result in sinking or collapsing of the dam. If small stones are used, they should be placed in the center of the gabion, with the large stones placed facing outside.

As gabion check dams are very expensive, proper care should be placed while placing the stones and constructing the structure. Therefore, to ensure stability and avoid collapsing of the structure against water pressure and sediment loads, the stone filled gabion check dams should firmly be keyed and placed at the bed of the gully into an excavated trench of 50 to 70 cm. Similarly, to avoid side erosion at the sides of the gully and reinforce the structure, the stone filled gabion check dams should also be keyed 50 to 70 cm into the walls of the gully.

Fig 2.16 Construction of stone filled gabion check dams

2.13 Brushwood Check Dams

Brushwood check dams are temporary structures constructed with tree branches, poles and twigs interwoven together, either by wire or sisal ropes. Brushwood check dams made of posts and brushes are placed across the gully. Plant species, which can easily grow through vegetative shoot cuttings, are ideal for this purpose. Brushwood check dams are suitable only for small gullies less than two meters deep.

The main objective of brushwood check dams is to retain sediment and to detain the runoff temporarily and allow it to filter through slowly. Small gully heads, no deeper than one meter, can also be stabilized by brushwood checks. Brushwood check dams should be built across the gullies either in single or double rows.

Brushwood check dams, which are built from plant material, which does not propagate by vegetative, do not normally last longer than three to four years. The expected life of these check dams depends up-on the type of the wood and its susceptibility to insect damage. A properly constructed brushwood check dam system requires large quantity of plant materials. Before deciding on choice of brushwood check dams, the availability of the material should be assured. It is also important to ensure that the scares removal

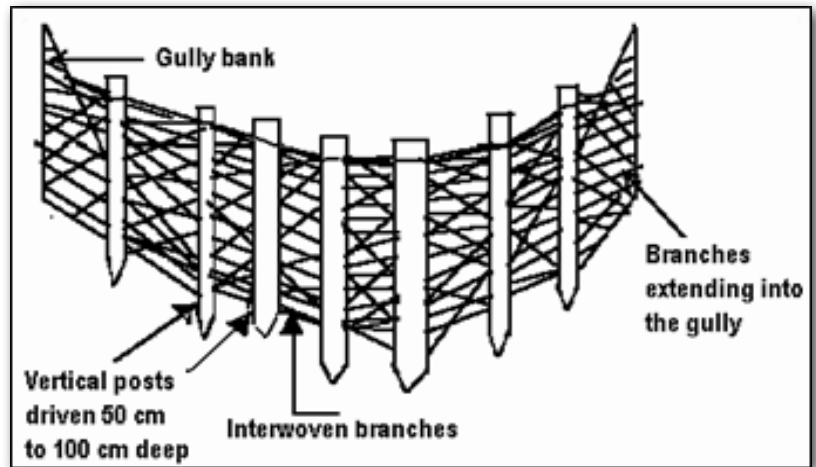

Fig 2.17 Brushwood gully check dams

of the plant materials from the watershed should not accelerate the soil erosion and deforestation. The plant materials required for brushwood check dams should be sorted out into relatively thicker and straight branches, 3 to 4 cm in diameter. The thicker branches will be used as vertical posts driven into the soil at least 60 cm in depth and spaced about half to one meter apart. The spacing between the posts will depend upon the height of the check dam. The higher the dam the closer the distance between the posts. If the row brushwood check dam is constructed, the minimum distance between the rows should be about 50 cm.



The posts should be driven into the soil so that they lean slightly up slope. After the brushwood check dams are driven into the soil (50 to 100 cm), the thinner branches or limbs are interwoven through the posts to form a wall. Each branch should be pushed into the gully bank up to 50 cm. These branches will strike roots in the banks and strengthen the dam. The soil at both ends of the dam is carefully packed down with feet. No soil should be dumped in the middle part of the dam. For a double row brushwood check dam, the brushes and other debris should be packed between the walls formed by the vertical posts and interwoven branches.

In areas where the soil in the gully is deep enough, brushwood check-dams can be used if proper construction is assured. The gradient of the gully channel may vary from 5 to 12 percent, but the gully catchment area should not be as huge as to produce a big runoff volume. Similarly, in the gullies which are long enough and have high pick runoff rate, the utilization of brushwood check-dams is very limited. There are two types of brushwood check-dams: these are single row and double row brush wood check-dams. The spillway crest of the brushwood check dam must be kept lower than the ends, allowing water to flow over the dam rather than around it or at its sides. The spillway of brushwood check dam can be either concave or rectangular shape (see Fig 2.17).

2.14 Log Check Dams

Log check dams, made of logs and posts are placed across the gully. They can also be built of planks, heavy boards, slabs, poles or old railroad ties. The main objectives of log check dams are to hold fine and coarse material carried by flowing water in the gully, and to stabilize gully heads. They are used to stabilize incipient, small and branch gullies generally not longer than 100 meter and with catchment areas of less than two hectares. The maximum height of the dam is 1.5 meters from the ground level. Both its downstream and upstream face inclination is 25percent backwards.

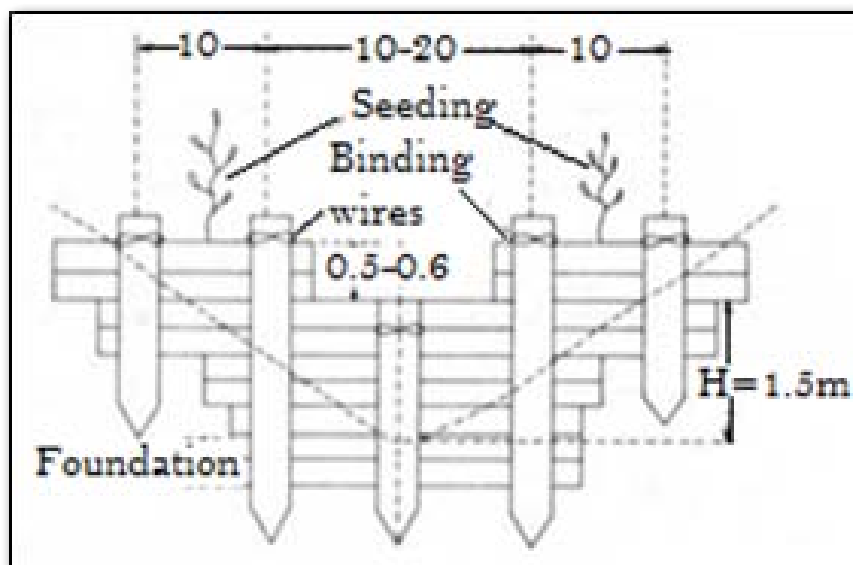

Fig 2.18 Design of log check dam

The spillways of log check dams can be rectangular. In general, the length and depth of its spillway are one to two meters and 50 cm to 60 cm, respectively (see Fig 2.18).

2.15 Gully Plugging

A gully plug is a low check dam, one meter high placed in a gully and is made of earth, rock, brush wood or a combination of these; and can be displaced by the force of water very easily. For proper stability of these check dams, they should have a slope of 1.5 horizontal to 1 vertical (1.5:1). Gully plugs are mainly built to prevent erosion and to settle sediments and pollutants. Furthermore, it is possible to keep soil moisture due to its better infiltration capacity.

Depending on the topography, amount of precipitation, material and financial resources available, there are several methods to construct a gully plug. Gully plugs have to be inspected regularly and any damage must be repaired. The main purpose of gully plugs (sometimes called earth plugs) is to hold runoff water and let it percolate into the ground. In arid and semi-arid regions, small gullies which are not deeper than 2 meters, with a gully bed gradient of less than 10 percent, can be stabilized by a series of earth plugs. In humid regions, however, gully plugs must be combined with small diversions.

Chapter 3

Design and Construction of Soil and Stone Bunds

3.1 Description

This technical design manual presents simple moisture harvesting techniques and technologies, which have been found useful in implementing labour intensive public works and are supposed to be effective and suitable for adequate moisture harvesting in Karamoja region and elsewhere in Uganda. From the experiences learned, the technical manual has attempted to show some successful events of application of water harvesting techniques in such moisture stressed semi-arid and arid areas. The appropriate planning and implementation of these techniques and technologies absolutely increase the overall productivity of labour intensive public works and other community based development activities that can build resilience for individual households and communities in such moisture stressed areas. In addition, implementation of soil and stone bunds are among the most common techniques and technologies that are instrumental in harvesting surface runoff water, increasing water infiltration and at the same time preventing soil erosion.

By building these physical soil and moisture conservation structures, runoff water is slowed down and conserved, and this leads to increased water infiltration and enhanced soil moisture. Using different design techniques, bunds are also applicable to even and uneven grounds, with a gentle slope of up to a maximum of 10 percent. Based on the availability of construction materials, these bunds are very often constructed either with soils or stones. These physical structures are most commonly used water harvesting methods for agriculture, particularly in moisture stress areas, which are instrumental in improving moisture storage capacity of the soil.

3.2 Basic Design Principles for Contour Soil and Stone Bunds

There are two commonly implemented types of bunds, namely, contour bunds (contour ridges) and semi-circular bunds. The choice of the type of these bunds depends on the local ground conditions and availability of construction materials. Contour bunds are constructed along a contour line in order to best slow down the water flowing down the slope, which increases the green water pool of the soil and prevents erosion. There should always be several bunds next to each other, whereas the distance between them depends on the slope and the soil type of the field. The steeper the ground, the closer are the bunds. Contour bunds can be used for both yearly field crops as well as the planting of trees, and their use is widespread in most moisture deficit areas.

A special and well-known type of contour bund is terracing contour bund, which is often used for moisture conservation and crop production. It is important to choose the right measures for semi-circular contour bunds, as the amount of collected water depends on both its height and the position of its tips.

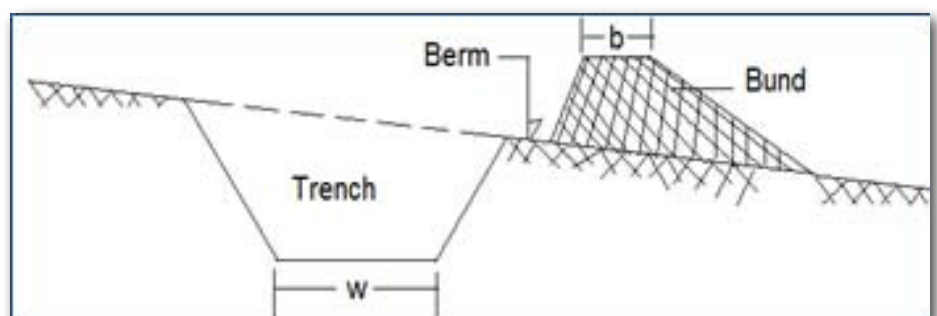

Fig 3.1 Contour trench design & construction

A further factor for the appropriate size of bunds is the selected crop. In moisture stress areas like Karamoja, properly designed and constructed contour bunds are effective for moisture conservation and agricultural productivity enhancement.



Fig 3.2 Benefits of flood water harvesting

Contour bunds are particularly constructed in agricultural lands with slopes ranging from one percent to six percent, and they are basically constructed in agricultural lands to increase the time of concentration of runoff or rainwater where it falls and thereby allowing runoff water to percolate into the soil. Contour

bunds are also useful to convert a long slope into several of them to minimize velocity and thereby reducing the erosion by runoff water. Contour trenches are used both on hill slopes as well as on degraded lands for soil and moisture conservation and afforestation purposes. The trenches break the slope and reduce the velocity of surface runoff. It can be used in all slopes irrespective of rainfall conditions, varying soil types and depths. Contour terraces can be continuous or interrupted, and the continuous terraces are used for moisture conservation in low rainfall areas. Continuous and interrupted contours require careful layout and are to be constructed strictly along or on the contours.

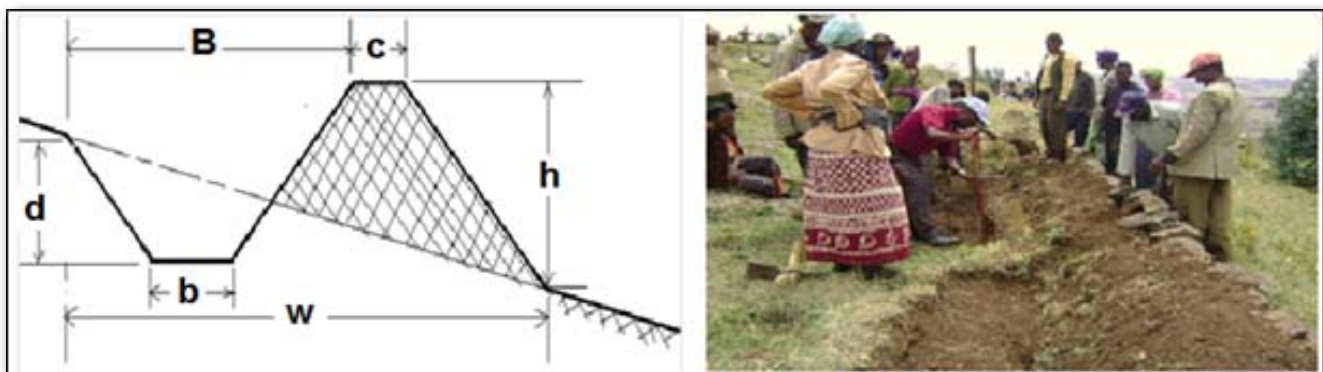

The size of the contour terraces depends on the depth of the soil. A trench may be of 30 cm base and 30 cm top width and square in cross section or it can be trapezoidal with side slopes 1:1 (see Fig 3.2, Fig 3.3). However, based on the rainfall to be retained and amount of moisture required, it is possible to make the contour terrace bigger. Bigger bunds are needed for fruit trees which require a radius and height of at least 60 cm. Furthermore, it is also important to leave free spaces between the bunds in order to enable collection of water as run off to the contour terrace. Similar to planting pits, semi-circular bunds are usually filled with organic matter to add nutrients for improved crop yield and other productivity intensification.

3.3 Semi-circular Bunds

Due to their half-moon design, semi-circular bunds have potential for more runoff water harvesting and are well suited for planting individual and high value trees. Contrary to contour bunds, each bund has to be made singularly by hand, making them much more time consuming in their implementation. As a plus factor, semi-circular bunds can also be applied to steeper fields (see Fig 3.4).



Fig 3.4 Design and construction of semi-circular bunds

3.4 Operation and Maintenance

The effectiveness of contour bunds may be enhanced by placing planting pits between the bunds and constructing upward ties. The ties are meant to create micro-catchments along the bund and can be built manually. These ties (or tie ridges) are important to prevent or avoid concentration of runoff water and prevent breaking of the bund at its lower or depression point. If there is excess rainfall, it may be helpful to build cut-off drains in order to let surplus runoff water to be drained safely.

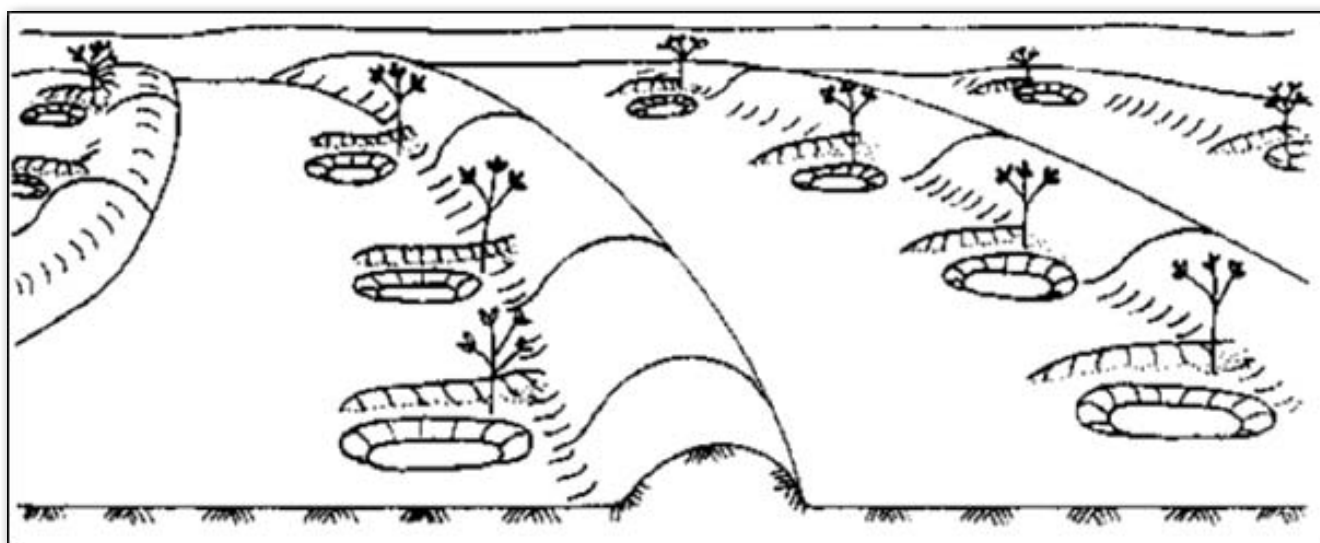

The required maintenance of contour bunds depends on the type of construction materials. For example, construction of bunds made of stones makes them very resistant to erosion and therefore only need limited on-going repair or maintenance. Earthen tie ridges on the other hand need to be rebuilt to their original height after each season. To limit maintenance to a minimum, it is important that the primary construction is done carefully and solidly with the required technical standards and requirement.

Biological stabilization or grass growing on bunds can further enhance the stability as its roots fix the soil. Contour bunds (contour ridges) are applied to sloping, but even terrain in order to catch runoff water and to prevent soil erosion and store nutrients from runoff water. Contour bunds are not, however, suitable for uneven terrain, whereas semi-circular bunds can be constructed on uneven ground and any slope, from almost flat terrain up to steep slopes. In fact, construction cannot be mechanized and implementation of

semi-circular bunds is more time consuming. Contour bunds effectively store surface run-off and prevent erosion. Implementation and maintenance of contour bunds is simple and cheap, and they are applicable to fields that are already under cultivation. However, the disadvantage for contour bunds are shortage of stones which can lead to higher implementation costs, contour bunds need an even ground, otherwise, water will collect in lower spots which can cause breakage of the bund at the lower spot.

Chapter 4

Design and Construction of Hillside Terraces

4.1 Description

A hillside terrace is defined as an earth embankment, or a combination of ridge and channel constructed across the field slope or along the contour lines. A hillside terrace is a practice applied as part of a resource management system for the purposes of reducing erosion by reducing slope length or retaining runoff for moisture conservation or both. Hillside terraces consist of a series of shallow ditches built along the contour lines at appropriate intervals. Hillside terraces not only break long slopes into shorter segments to intercept surface runoff, but also serve as farm paths to facilitate farm operations. Hillside terraces are suitable on slope gradient between 12% and 40%. Hillside terraces can be continuous, discontinuous, transitional, drainage, absorption and soil retarding types.

- * Continuous type of terraces are irrigation or level bench terraces, and upland bench terraces.
- * Discontinuous type of terraces are hillside ditches, orchard terraces and individual basins.
- * Transitional type of terraces are convertible and intermittent terraces constructed on gentle slopes (less than 12% or 7 degrees).
- * Drainage type terraces are broad-based graded terraces.
- * Absorption type terraces are broad-based level terraces.
- * Soil retarding type terraces are natural terraces.

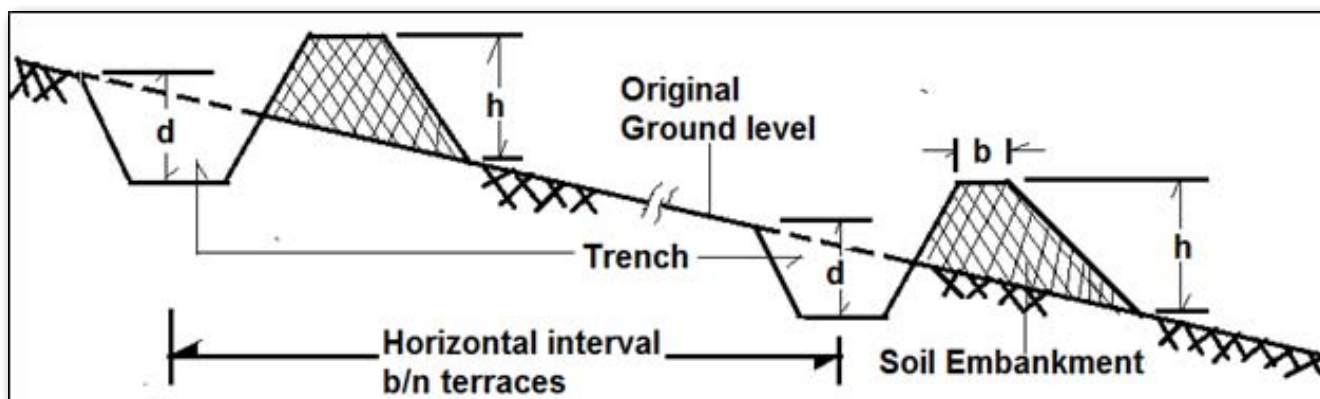

Fig 4.1 Design and construction of hillside terraces

Hillside terraces are mainly used for erosion control and for growing crops on sloping lands. The selection of suitable types of terraces depends on many factors, including physical conditions of the site such as slope, soils type, rainfall; socio-economic conditions (such as labour conditions, land use patterns, cropping and farming systems, population densities); and land owners' conditions and interests and willingness to accept innovations; available resources, farming practices and main crops; and farm tools to be used. When planning the application of terraces or any labour intensive soil conservation work, farmers or land users should make the final decision. However, local government authorities or watershed management experts or conservationists should assist the farmers by examining the site and explaining the types of treatment needed.

4.2 Purpose and Scope of Level Terraces

This standard is intended as a guide to technicians for the design, layout, construction and maintenance of terrace systems on cropland and hillsides that use different equipment and techniques. Terraces are earth embankments and channels constructed across the slope at suitable spacing and with acceptable grades for one or more of the following purposes:

- ▶ To reduce soil erosion.
- ▶ To provide maximum retention of moisture for crop use (maximum moisture conservation).
- ▶ To remove surface runoff water at a non-erosive velocity (in high rainfall areas only).
- ▶ To reform land surface and improve farm ability and productivity.
- ▶ To reduce sediment content in runoff water.
- ▶ To reduce peak runoff rates to installations downstream.
- ▶ To improve water quality.

Terraces alone usually will not provide adequate soil erosion control on sloping lands. They should rather be installed as part of a system of conservation practices that address the runoff from cropland. Erosion control requires a complete water disposal system which may include waterways, underground outlets, water and sediment control, and drop structures. Other conservation practices usually recommended in conjunction with terrace systems are contour farming, crop rotations, contour strip cropping, conservation tillage, residue management, nutrient management, pest management and good soil management. Each measure shall be planned for compatibility with modern farm equipment and shall be optimally beneficial for soil and water conservation. Natural features, permanent boundaries, and the location of auxiliary features such as fences and field roads shall be considered to enhance farm ability during terrace system design and layout. Conditions where this practice is applied include areas where:

- * soil erosion caused by water and excessive slope length is a problem;
- * excess runoff is a problem;
- * there is a need to conserve water (in moisture stressed areas);
- * the soils and topography are such that terraces can be constructed and reasonably farmed;
- and,
- * a suitable outlet can be provided.

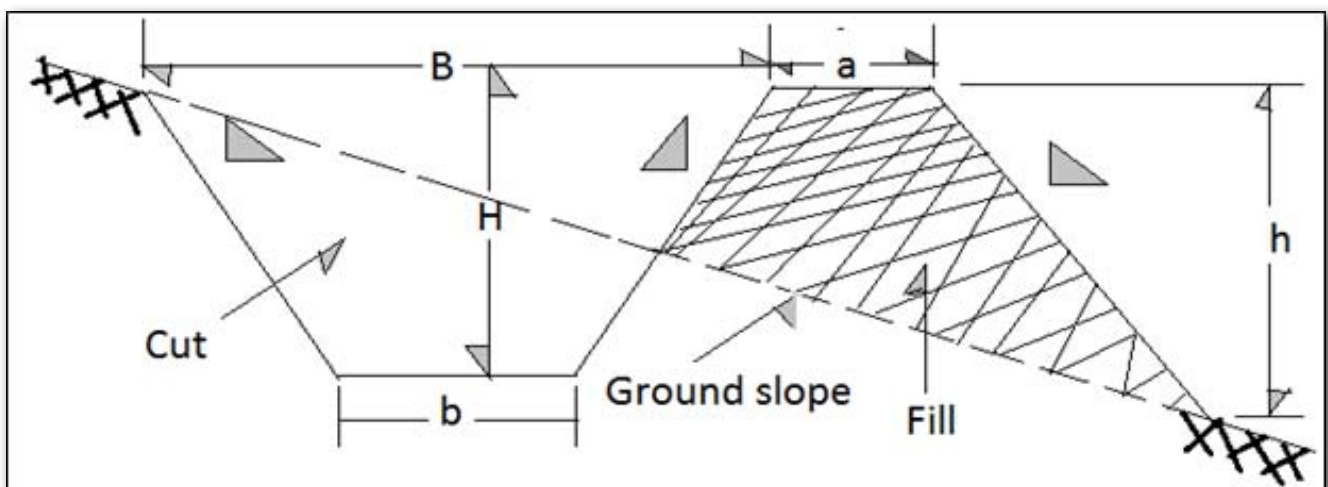

Fig 4.2 Design and construction of hillside ditch

When planning the application of terraces or any soil conservation work it is the farmer or the land owner who should make the final decision. However, local government officers or watershed conservationists should assist the farmer by examining the site and explaining what treatment is needed. In areas with heavy rainfall and/or heavy soils, the graded or drainage types of terraces are used while in areas with light rainfall and/or light soils, the level or moisture conservation types of terraces are generally used. On small farms situated on gentle slopes, natural terraces which possess the advantage of being labor-saving, can be employed.

4.3 Criteria for Selection of Terraces

1. **Spacing:** Terraces are spaced at intervals across the slope to achieve the intended purpose. The maximum spacing of terraces for erosion control is necessary to achieve soil loss tolerance (T). The slope length used when checking soil loss for a proposed terrace spacing is the distance from the terrace ridge to the next lower terrace channel measured along the natural flow direction (see Fig 4.3).

Maximum spacing for erosion control based on soil loss tolerance may be increased by as much as 10 percent to provide better location and alignment to accommodate farm machinery or to reach a satisfactory outlet. The methods that may be used to determine terrace spacing include the vertical interval equation or state developed methods that address unique soil, cropping or other farming practices that affect terrace spacing. Spacing between two consecutive terraces or bunds can be calculated by using the following formula:

$$H.I = \frac{V.I}{S} * 100$$

Where:

H.I = horizontal interval or spacing in meter.

V.I = Vertical interval in meter.

S = Slope of the land in percent.

Subsequently, the length of terraces or bunds (L.B) per hectare of land can be calculated by using the following formula:

$$L.B = \frac{100 * S}{V.I} = \frac{10,000}{H.I}$$

2. **Alignment:** To accommodate farming operations, cropland terraces are designed with long gentle curves. When multiple terraces are used in a field, design of terraces is parallel to one another as practicable.
3. **Terrace cross section.** The cross section of the terrace should be proportional and fit to the land slope, the crops grown, and the farm operations used. Add ridge height if necessary to provide for settlement, channel sediment deposits, ridge erosion, the effect of normal tillage operations, or safety. At the design elevation, the ridge shall have a minimum width of 0.90 m. For terraces with open outlets, the capacity of the outlet is designed to be equal to or greater than the capacity of the terrace channel (see Fig4.3).

All farmable terrace slopes shall be no steeper than those on which farm equipment can be operated safely, and for non-farmable terrace slopes, the steepest allowable slopes are 2 horizontal to 1 vertical, unless an analysis of site specific soil conditions indicate that steeper slopes will be stable.

Vertical Interval (V.I) between terraces can be calculated by using the following formula:

$$V.I = \left[\frac{S}{100} \times H.I \right]$$

Where:

S = land slope in percent.

H.I = horizontal spacing between two consecutive terraces in meter.

4. **Capacity:** Terraces are designed to have enough capacity to control the runoff from a 10-year frequency, 24-hour storm without overtopping. For terrace systems designed to control excess runoff or to function with other structures, a larger design storm appropriate to the risk associated with the installation is chosen. The capacity of terraces is increased by the estimated 10-year sediment accumulation, unless the operation and maintenance plan specifically addresses the annual removal of sediment. For terraces with open outlets, the capacity is based on the size of the terrace channel and stability.
5. **End closures:** Level terraces may have open ends, partial end closures, or complete end closures. Partial and complete end closures are used only on soils and slopes where stored water will be absorbed by the soil without appreciable crop damage or where underground outlets are provided. If terraces with closed or partly closed ends are specified, the end closures are installed before the terraces are completed. End closures less than or equal to half the effective height of the terrace ridge are considered partial closures while those greater than half the height are considered complete closures. The cross sectional area of the end closure fill may be less than the terrace cross section. For level terraces that have end closures, which are lower than the terrace ridge elevation areas downstream from the end closure, must be protected from flow that will exit from the closure before the design storm is reached.
6. **Channel grade:** The terrace channel is designed to be stable with non-erosive velocities but with sufficient grade to prevent damage to crops or to prevent delay of farming activities from prolonged ponding of runoff. The maximum velocity for erosion-resistant soils (clay textured soils classification) is 0.75 m/s; for average soils (silt textured soil classification), 0.61 m/s; and for easily erodible soils (sand textured soil classification), 0.46 m/s. If Manning's Equation is used to compute velocity, a maximum value of n, to determine velocity for channel stability is 0.035.
7. **Level terrace length:** The volume of water stored in level terraces is proportional to the micro-catchment area that delivers runoff water to the terrace, which is directly proportional to the length of the terrace. To reduce the potential risk from failure, do not design level terraces with lengths that exceed 1,000 m unless the channel is blocked at intervals not exceeding 1,000 m.
8. **Vegetation:** Stabilize all areas planned for vegetation as soon as possible after the construction of the terrace.
9. **Drainage:** Install subsurface drainage to stabilize soils and improve terrace function as needed.

10. Outlets: All graded terraces in high rainfall areas must have adequate outlets. The outlet must convey runoff water to a point where it will not cause any damage. Vegetated outlets are suitable for gradient or open-end level terraces. Grassed waterways or naturally vegetated waterways may be used as a vegetated outlet. Grassed waterways should be installed and stabilized prior to the construction of the terrace so that the terrace will have a stable outlet when it is constructed.

In order to avoid scour in the channels, the gradient of graded terraces should not exceed 0.5 percent. Hence, graded terraces are to be laid out at a gradient of 0.2—0.5 percent. Subsequently, cutoff drains are essential mechanical structures to dispose runoff water coming from up slopes and hillsides or hillside terraces at safe velocities and protect cultivated lands. Therefore, for laying out cutoff drains a gradient of 0.5 - 1.0 percent is recommended. Field trials show that cutoff drains constructed at 2% gradient scour the channel very rapidly and cause bed erosion. With gradients of cutoff drains exceeding 1% and waterways of gradient exceeding 4%, the use of scour checks is very effective in controlling channel scouring.

As the choice of safe outlet is very essential in the design of cutoff drains, the lay out and survey of cutoff drains should start from the outlets. Enforcing of the outlets with short growing local grasses or paving with stones is necessary. Similarly, scour and erosion protection is essential for waterways because of two reasons. First, the cross section necessary for easy navigation has to be guaranteed, so no deposition of material in the navigation channel due to sediment or bed load transport or slope instabilities shall hinder navigation. Second, waterways often lead flood water through some potential and important areas, so stable banks and canals are of particular importance. Therefore any conceivable damages or failures have to be ruled out by corresponding protection measures.

4.4 Technical Specifications for Terrace Design and Construction

The technical and work norm specifications for hillside terraces design and construction include:

- * Cut and fill of the terrace area.
- * Collection of stones from working site, including light shaping of side of some stones with sledgehammer for better stability & merging.
- * Excavation of foundation.
- * Placement and building of stone riser.
- * Small stone ties every 5 m (optional).
- * Leveling of top of terrace with an A-frame or other layout instruments.

The technical dimension of terraces also include

- ◆ Height or soil/ stone riser.
- ◆ Width of terrace.
- ◆ Foundation and grade of stone riser.

In low rainfall areas, hillside terraces have 5 - 10% back slope gradient. As indicated in Fig 4.4, the minimum technical dimensions or standard of terraces are:

- ♣ A minimum height or soil/stone riser (H) of 0.5 m (ranging from 0.5 to 0.75 m)
- ♣ 1.5 m minimum width (W) of terrace (ranging from 1.5m to 2m)
- ♣ 0.3 m depth (d) and 0.3 m width of terrace foundation (b).
- ♣ Well-placed stone wall riser(1 horizontal to 3 vertical).
- ♣ In lower rainfall areas hillside terrace have 5-10% gradient back slope.
- ♣ Integration with micro-basins or other structures in between terraces is recommended.

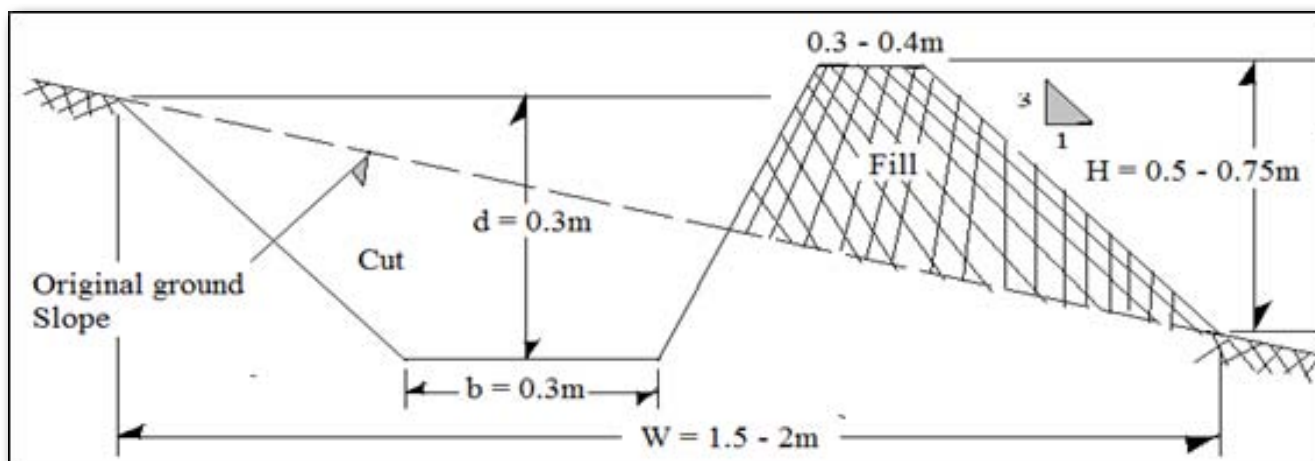

Fig 4.4 Design dimensions for contour terraces

4.5 Planting on Soil Bunds Terraces

Though the work norm for planting on soil bund terraces is not clear and subject to various interpretations, the common use is planting of grasses on bunds. However, this was not correct since grass rows on bunds should be named as a bund stabilization activity as per its immediate effect in stabilizing the embankment. In this regard planting on bunds should be regarded more as an intensification and productive use of the structure rather than a stabilization activity. Ultimately planting of trees and shrubs plays a great role in stabilization, but more in the medium and long term objectives. For practical purposes, planting on bunds is considered a separate activity from bund stabilization.

Regarding planting on bunds, only legume shrubs are considered since trees planted on bunds are activities which may be considered as a voluntary effort because trees are widely spaced along bunds. Planting on bunds is exclusively referring to planting of various structures with dense rows of legume shrubs (Pigeon Peas, Sesbania, Leucaena, Tree Lucerne, etc.) for various uses, principally for fodder but also grain (Pigeon Peas, Sesbania) and branches. This effort is meant to encourage farmers to render productive the various structures and control free movement of animals in these conserved and productive areas.

In addition to graded or level bunds and Fanny Juus, planting on bunds is also referring to the stabilization of cutoff drains and other structures with soil embankment. Bund stabilization with productive shrub seedlings assumes a minimum standard spacing between plants of 0.3 m in a single row placed on one side of bund (side of berm) or at its top. Taking into account the standard minimum spacing, double row is also possible as well as closer spacing within row (0.2 m). The work norm for bud stabilization may include preparation of niches or small pits for planting, handling of seedlings from storage area, and plantation and soil compaction around seedlings.

Community-Based Rainwater Harvesting Techniques and Technologies

5.1 Description

Rainwater harvesting is the most important and highest priority of the community in arid and semi-arid areas for human and livestock uses and agricultural production. In arid and semi-arid areas (dry areas), like Karamoja, which are characterized by low annual rainfall and varying distribution time, rainwater harvesting techniques and technologies are the top priorities of the rural communities. Though water harvesting in such dry areas supports a flourishing agriculture and other livelihoods development, its sustainability largely depends on the reliability, selection of technologies, timing and the amount of rainfall. Thus, though the term water harvesting is used in different ways, it is practiced more in arid and semi-arid regions where:

- ♣ surface runoff often has an intermittent character;
- ♣ average annual rainfall is at least 100 mm in winter rains and 250 mm in summer rains;
- ♣ requires a runoff producing area and a runoff receiving area; and
- ♣ Storage is an integral part of the water harvesting system.

The runoff water may be stored directly in the soil profile or in small reservoirs, tanks, aquifers and other storage facilities. Water harvesting can more precisely be defined as the process of concentrating rainfall as runoff from a larger catchment area to be used in a smaller target area. As the basic source of all water on earth is rain, it can be harvested from any point of hydrological cycle. Runoff water arising from uncontrolled rainwater is the greatest agent of soil erosion, which subsequently gives rise to other forms of land degradation.

In order to sustain the natural resource base as a whole, the environment must be conserved through controlled and conserved rainwater. Water harvesting techniques and technologies therefore serve the dual purpose of preserving the environment and providing water to the most needed commodity. In fact community-based small-scale rainwater harvesting is not just capable of providing more than drinking water needs in the worst of drought situations but is also the most efficient way to collect water. It does not matter how much rain we get, if we don't capture it we can still be short of it. It is, therefore, very important to capture this rainwater, which just comes and goes in a few hours. In areas where water is scarce, if we don't harvest the rainwater, there will never be enough water to meet the drinking, cooking and other water requirements.

Therefore, rainwater harvesting is the most important and highest priority of the community living in Karamoja, both for human and livestock water supply and for agricultural production. This technical manual therefore presents the rainwater harvesting techniques and technologies that are common and important for multifaceted purposes in the region. For uncompromised reasons, rainwater harvesting in Karamoja is, therefore, more essential and spatial intervention to maximize effective and efficient utilization of such untapped potentials to meet the required demands.

As the appropriate choice of technique depends on the amount of rainfall and its distribution, soil type and depth, topography, and local socioeconomic factors, water harvesting in these districts should be site-specific.

Hence, the strategy for drought mitigation and resilience development in Karamoja would be to ensure that every village or community captures all the runoff water resulting from the rain falling over its entire land, especially during years when the rain is normal, and store it in ponds or other storage facilities to use it when it is required. For effective use of rainwater harvesting to happen, the planners will have to stop confusing irrigation for drought mitigation with large-scale irrigation for green revolution-type of agricultural development. Otherwise, the region may get its priorities wrong and the poor people will continue facing the challenges of the prevailing water scarcity. Depending on the availability of resources and solution of problems like rehabilitation, both can be attempted, but the priority must go to drought-proofing measures, which require little support in comparison with untapped resources and will bring tangible results very quickly, within at least 5-10 years.



Fig 5.1 Rock catchment runoff water harvesting (Kotido)

Small-scale irrigation will have to depend either on groundwater or local water harvesting. The groundwater or local water harvesting will also have to go together because heavy use of groundwater can only be sustained if there are local efforts to keep on recharging the groundwater. Hence, large-scale irrigation development may not be the substitute for drought proofing based on local water harvesting systems and sustainable use of groundwater. Though big dams may help to create pockets of green revolution-style agricultural production (with water-intensive crops), they cannot be drought-proof for the whole community. As a result they can at best create 'national' food security, which means that few areas can generate a huge agricultural surplus.

As local food security is as important as national food security, water harvesting in Karamoja can definitely be drought-proof and create local food security which other options cannot. Then the poor people and vulnerable people will not have to suffer the humiliation of the kind they have had to suffer every year. However, it has to be realized that the region cannot survive on a single-track water management. It is indeed important to realize that the food security of the region even from its rural development strategies

in the rural communities will depend heavily on a nation-wide agricultural development intensification programme, which can be taken by individual community through rainwater harvesting. If this is not done, the rural community will continue to suffer because of the increasing scarcity of water for crop production across the region. During critical years when water is scarce, the solution is harvesting rainwater through capturing, storing and recharging it and later using it during prolonged parched periods.

Indeed, local governments, development partners and several village communities in Karamoja have shown their commitment, potential and perseverance in drought-proofing efforts, but this still needs demonstrative extension supports.



Fig 5.2 Effective runoff water collection rock catchment in Kotido

The key component of water management is rain water storage, especially where the average annual rainfall is low. This low and precious rainwater can be harvested or stored in small ponds, storage dams, small earth dams, with small catchments, or by storing it in a way that it percolates down into the ground and gets stored as ground water. In fact, a number of factors determine how much rain falls over a catchment

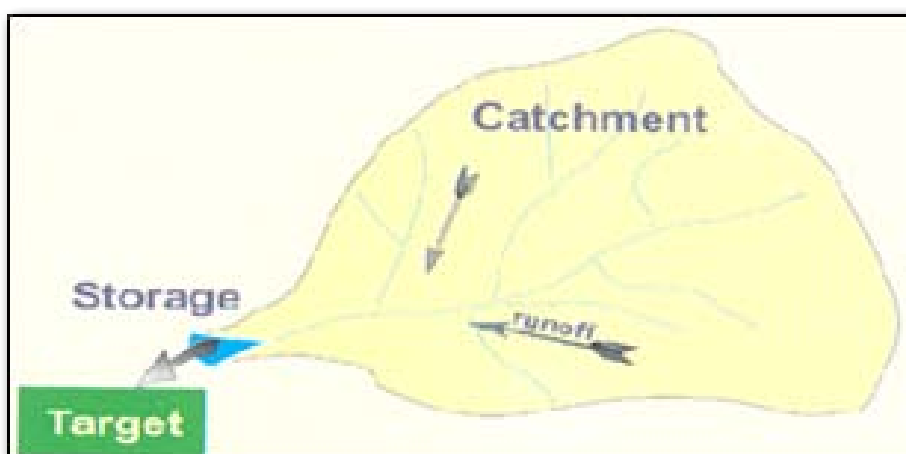

Fig 5.3 Runoff water harvesting & storage

will turn into runoff, which can be collected by communities or villagers for their drinking and small scale irrigation needs. All other factors like slope type, vegetation cover, topography, soil moisture, rainfall characteristics remaining the same, the larger the size of the catchment, the less runoff water can be collected from that catchment.

Generally speaking, runoff water harvested from a small watershed is much more in quantity than the runoff water collected from a larger watershed. This is because in a large catchment, water has to run over larger distances before it gets collected and during that long distance, a lot of runoff water is lost in puddles and small depressions, through evaporation, infiltration or percolation into the soil.

Therefore, smaller catchments give the maximum water, and the difference can be quite high. Many studies have shown that increasing the size of the catchment from one ha to about 2 ha reduces the water collected per hectare by about 20%. Several other studies conducted by many rainwater

harvesting research institutes have also found that smaller watersheds (or catchments) give higher amounts of water per hectare of catchment area. In simple terms, all this means that in drought-prone areas, like districts of Moroto, Napak, Kaabong, Kotido and other districts, where water is scarce but precious, 10 tiny dams or ponds with a catchment of 1 ha each will collect much more water than one larger dam with a catchment area of 10 ha. In other words, smaller catchments give much more runoff water than larger catchments. For example, only with an annual rainfall of 100 mm falling on a one-hectare plot can yield up to one million liters of water. As shown in Table 5.1 below, 300 micro catchments of 0.1 hectare each will give five times more water together than one catchment of 300 hectares even though the total land area from which the rain harvested remains the same.

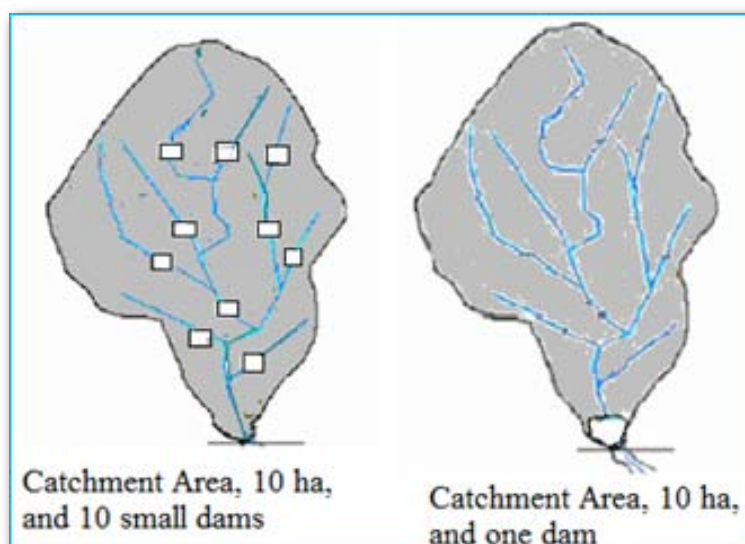

Fig 5.4 Effective area for runoff water

Size of catchment (ha)	Quantity of water harvested, m^3/ha	Percentage of annual rainfall collected
Up to 0.1 ha	160	15.21%
20 ha	100	9.52%
300 ha	50	3.33%

Source: Michael Evenari, et al 1971. *The Challenge of a Desert*, Oxford University Press, UK.

5.2 Priorities of Community

Before selecting any specific water harvesting technique and technologies, due consideration must be given to the social and cultural aspects prevailing in the areas of concern, as they are paramount importance and will affect the success or failure of the technique and technologies to be implemented. This is particularly important in the arid and semi-arid regions and may help explain the failure of so many projects that did not take into account the priorities of communities. In arid and semi-arid regions, most of the population has experienced basic subsistence regimes which resulted over the centuries in setting priorities for survival. As a rule of thumb, until all higher priorities have been satisfied, no lower priority activities can be effectively undertaken.

While selecting and checking the sequence of labour intensive water harvesting works and their priorities, the planner must also consider the alternate sources of water. These must be compared with water harvesting cost and the risk to be involved, and this comparison must take into account the water quality required, operational and maintenance costs as well as the initial cost. Where alternate water is of a better quality, cheaper to develop, easier to obtain or involves less risk, priority should be given to this activity. For example, an alternative choice is the development of springs or shallow wells for micro-scale irrigation, prior to runoff water harvesting.

5.3 Basic Technical Criteria for Water Harvesting

A water harvesting scheme will only be sustainable if it fits into the socio-economic context of the area and fulfils a number of basic technical criteria. The basic technical selection criteria for different water harvesting techniques include ground slope, soil type, quantity of earthwork and its cost, etc. The ground slope and shape of the catchment is a key limiting factor for water harvesting. For example, water harvesting is not recommended for areas where slopes are greater than 5% due to uneven distribution of run-off and large quantities of earthwork required which is not economical. In this regard, the soil type and its suitability for irrigation will also have main attributes. For example, the soil should be deep, should not be saline or sodic and ideally it should possess inherent fertility. Soils with a sandy texture are a serious limitation for the application of water harvesting. If the infiltration rate is higher than the rainfall intensity, no runoff will occur. The quantity of earth/stonework involved in the construction directly affects the cost of a scheme or, if it is implemented on a self-help basis, it indicates how labour intensive its construction will be.

5.4 A Prerequisite for Effective Water Harvesting

Community-based rainwater harvesting may well become a widely adopted paradigm in the years to come, both in the urban and rural areas. But the question is, will this all lead to effective results, especially in the rural context? Building water-harvesting structures is a very easy task, but building an effective structure which starts off a process of self-management in villages or communities is a much more difficult task. This is possible only if each structure is the result of a cooperative social process of a community to work in cooperation. In fact, water is a strange natural resource which can unite a community as easily as it can divide them. Therefore, it is essential that a strong mind set up and social process precede each structure to build the 'social capital'. The first task of any water-harvesting programme will have to be then spent on social mobilization. This will mean, firstly, creating awareness, mind set up and confidence building in the community that water harvesting works. Once this is achieved, it means sitting with the people to create village or community institutions which will decide where, when and how the water harvesting structures will be built; who will build the structures; how much the villagers will provide to share the cost of the structures; and once the structures are built, how will the benefits be sustainable; how will the water be shared amongst the villagers or households, especially in the areas where water is scarce; and how its use will be regulated and sustained. Every member of the community, from the land owner to the landless and women's groups will have to be involved by making each section, to appreciate the social and economic benefits that will be derived from it and by making efforts to ensure that benefits do indeed flow to each section of the community. Therefore water harvesting works best when combined with watershed development. Those who have land benefit leaving the landless without any benefits and therefore alienated from the exercise. However, development of watersheds to conserve both water and soil also increases soil and water conservation;

and plant and grass production on what are usually common lands, which can greatly benefit landless households, and also increases the life and effectiveness of the structures that benefit the land owner by reducing siltation.

Nothing works better than when villagers see all this in actual practice. For this purpose, it is important to have experience sharing visit to take villagers to see other communities where such principles are being observed and how water harvesting has changed their lives and livelihoods. Organizing field travel with communities to see neighboring communities or villagers who have done effective water harvesting can help communities talk face to face with those who have not done it. As the effects of water harvesting is a gradual process, one must be prepared to accept that the first year's effort will bring little effect, second and



Fig 5.5 Shallow depth and wide storage areas lead to more evaporation losses (Napak)

third year maybe something, and fourth and fifth years hopefully mean a lot. The number of villages participating in water-harvesting programme could grow slowly in the first year and then very rapidly in the later years as the villagers become more and more confident of the value of what they are doing. Social mobilization is essential for the success of water harvesting for several reasons. Firstly, the community must be closely involved in the construction of the water harvesting structures to ensure that they are built with technical competence; that is, the site is chosen properly, the technical parameters and specifications are correct, etc. Poorly built labour intensive water harvesting structures will not deliver water and can get easily washed away. Secondly, even in properly built structures which deliver water, once the water starts getting available either as increasing levels of groundwater or as surface water in a pond or tank, the community will have to start managing the available water which in the earlier years may not be enough to irrigate lands of all the farmers. Institutional coordination among key and relevant partners and other agricultural extensions is essential for sustainable watershed development and water harvesting programme to succeed and become sustainable.

Practically speaking, rainwater harvesting can easily eradicate rural poverty in Karamoja, if watershed development and water harvesting programmes are driven by the demand of the community and are handled well. From the lessons learned and untapped potentials of the areas, rainwater harvesting in these areas should not only be just the point for meeting drinking water needs but also the starting point of an effort to eradicate rural poverty itself and generate massive rural employment.

Increased and assured water availability should mean increased and stable agricultural production and improved animal husbandry both of which together form the fulcrum of the rural economy. Another interesting dimension of community-based rainwater harvesting is that it helps generate a community spirit within the community and build up the 'social capital'. As traditional rain-fed agriculture constitutes the bulk of the cultivated land in districts of Karamoja Region, efficient rainwater harvesting is indispensable for fortifying food security provided that water harvesting along with political wisdom is spearheaded by local authorities, development partners and user communities to help solve rural poverty. Rainwater harvesting in Karamoja can, therefore, help communities transform themselves from the current vulnerable situation to reliable food security and a resilient situation if it is properly managed.

5.5 Challenges and Opportunities of Rainwater Harvesting in Karamoja

Rains produce plenty of clean water running off from land surface, roads, and rock surfaces. This rainwater running off from these different surfaces can be stored during the rain seasons to use it for the dry seasons when it is needed most. From the ongoing practical exercise and experiences, there are four possible potential ways of storage for runoff water harvesting in Karamoja, namely: storage in reservoirs (such as earth dams and ponds); storage in sand dams; storage in-situ; and storage through groundwater recharging. In this area, there are many types of structures suitable for rainwater harvesting but nearly all of them lose water in many ways, and the major water losses are through evaporation and seepage. In hot climates, like Karamoja, evaporation losses from surface reservoirs may amount to about 3mm/day (which is equivalent to 9.0 m³ water in a month from 10 m² of a reservoir area), and the second major water loss is seepage through the floor of these earth dams and other surface reservoirs.

Therefore, in these areas about half of the water stored in earth dams and other open storage reservoirs may be lost mainly due to evaporation and seepage. Hence, in such areas where the water losses are significant, reservoirs may be built to store double the volume of water required. Though it is necessary to take different efforts to minimize these considerable evaporation and seepage losses, it is also important to consider these losses and possible measures when planning and designing water storage projects for either water for domestic, livestock or irrigation uses. The other cheapest method of storing rainwater is to recharge shallow

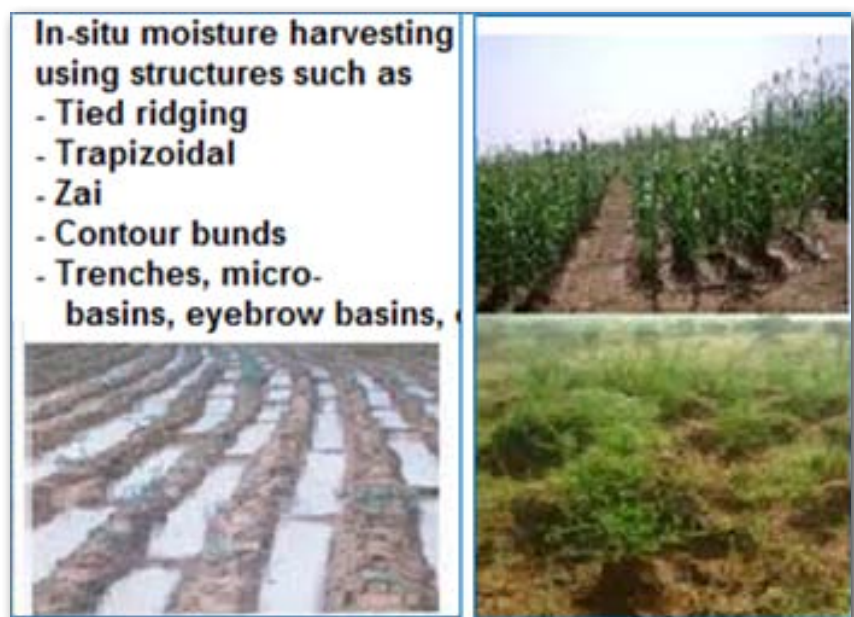

Fig 5.6 Potentials of in-situ moisture harvesting in moisture stress areas (arid & semi-arid areas)

ground water aquifers and sand dams during rainy seasons and draw it by means of hand-dug wells throughout the year during the dry seasons. However, this cheap method may not always succeed because the water may seep deep into the underground where it becomes salty and unfit for human consumption; it may be too deep for shallow wells and requires investment in expensive boreholes and pumps; and it may not easily be found in the underground. Another option, which is already being attempted by

local government, development partners and local farmers is to divert flood water from roadsides and other runoff areas onto nearby farmlands, water storage structures and grazing lands. However, as these techniques may often create erosion, deep gully formation and sedimentation of water reservoirs, serious care has to be taken when diverting such runoff flood from roadsides into farmlands, storage reservoirs or grazing lands. In fact, if protective and careful measures are taken in diverting this roadside flood water into the farm lands, water ponds, or ground tanks, this potentially destructive practice can be changed into a useful and profitable benefit for the farmers.

Though most stakeholders and farmers in Karamoja know and apply some of these techniques of soil moistures that make rainwater percolate into the soil instead of eroding the farmland, they still need better technical support and advisory services. In general, rainwater harvesting in Karamoja is the most viable water supply option if catchment areas are well protected and preserved, water storage reservoirs are made large to store more runoff and clean water for longer periods, evaporation and seepage losses are minimized, groundwater table is recharged, and the sand riverbed storage are improved and expanded.

Evaporation loss can also be minimized by increasing the depth and reducing surface areas of reservoirs and other storage facilities (if possible by roofing small storage reservoirs). Similarly, seepage losses can be minimized by compacting and plastering or covering the floor of reservoirs or storage facilities with clayey soil. To design successful and cost-effective rainwater harvesting structures, it is important to know how much rainwater falls on a given catchment area and the net runoff water that can be collected from the catchment area.

Design and Construction of Moisture Harvesting Contour Trenches

6.1 Description

Planting pits are the simplest form of in-situ rain water harvesting for optimizing moisture conservation for plant and crop production (see also bunds, field trenches, micro basins, retention basins, and controlled drainages, which have similar purposes). This form of micro-catchment is best suited for land with low permeability, such as silt and clay soils. On encrusted soils, three types of conservation practices can be met with planting pits: soil conservation; water or moisture conservation; and erosion protection. To further increase crop and biomass production, organic matter such as compost or manure can be placed in the pits as organic fertilizer. Many different names are used for planting pits, such as zai pits.

Similarly, field trenches increase runoff water harvesting by breaking the slope of the ground and therefore reducing the velocity of runoff water. By decreasing runoff, they enhance water infiltration and prevent soil erosion. Trenches can be seen as an extended practice of ploughing fields. They may be applied to all soil types and are not dependent on slope or rainfall conditions. Trenches can be seen as extensive ploughing techniques to the right angle of a field's slope. By breaking the slope and, therefore, reducing the velocity of runoff water, field trenches filter runoff water from rainfall and hence reduce soil degradation and enhance infiltration of surface runoff and soil moisture.

A great advantage of field trenches in comparison to other types of water harvesting measures, such as bunds, planting pits, micro-basins, and retention basins, is their applicability to all soil and rainfall conditions. Trenches may be added to steep slopes as well as an even land and can be used for all types of soil depth.

6.2 Basic Design Principles

Planting pits have a very simple design. The diameter of the pit is usually between 15 and 50 cm (depending on the soil texture and structure), but they sometimes also exist in much greater sizes. The depth of each pit should be between 5 and 15 cm. Planting is best done in straight rows or along the contour lines with a distance of 50 to 100 cm between each pit. This is equal to 10,000-25,000 pits per hectare. If the soil is already very shallow, planting on the top of the ridges can be beneficial, as the soil may be too shallow for crops and other biomasses to grow within the holes or pits. To further improve crop growth, and some other high value trees, organic fertilizer such as compost or manure can be placed in the pits.

When heavy rainfall occurs, the organic matter can additionally help soak up excess water, preventing unwanted water accumulation. In combination with stone lines, planting pits can be used to rehabilitate degraded and crusted land. The stone lines are spaced at a distance of 25 to 50 m and help further hold back moisture and eroded soil. In combination with stone lines, planting pits can be used to rehabilitate degraded and crusted land.

At its simplest form, contour trenches or pits are ditches dug along a hillside in such a way that they follow a contour and run perpendicular to the flow of water. While the continuous trenches are best suited for moisture conservation in regions with low rainfall, interrupted trenches are best suited to high rainfall areas. The soil excavated from the ditch is used to form a berm on the downhill edge of the ditch and can

be planted with local grasses and legumes to stabilize the soil and trap any sediment that would overflow from the trench in heavy rainfall events (see Fig 6.2). The suitable conditions to be noticed in trench design and construction are to locate trenches in natural runoff areas, but not on slopes over 10%; and soil in the area needs to have sufficient infiltration capacity and potential sub-surface storage capacity.

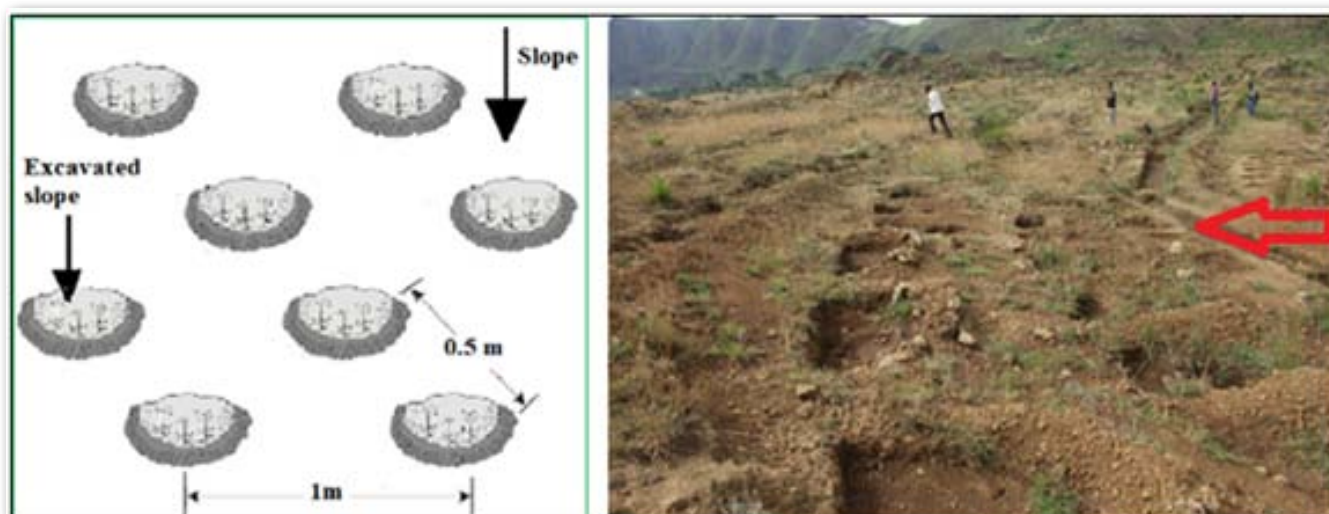

Fig 6.1 Typical & staggered runoff harvesting pits for effective moisture harvesting

Moreover, in areas with very heavy storms it may be dangerous to prevent the water completely from flowing down a slope, it is therefore necessary to build waterways or drains to channel away the excess water to safe outlets. In fact, the optimal distance between two trenches depends upon the slope of the field. But steeper grounds require less distance. Entirely preventing runoff water may be dangerous if extremely heavy rainfall occurs. In this regard, to control excess runoff water, building cutoff drains or waterways that can channel the excess runoff to a safe outlet is paramount importance to be considered.

Contour trenches facilitate the recharge into surrounding ground which in turn improve soil moisture, agricultural productivity and grazing potential, increase water for livestock, mitigate shocks against drought; reduce soil erosion; support recharging shallow wells; reduce salinity in groundwater; prevent pollutants from draining into water bodies; and support gully plugging with existing gully drainage pattern.



Fig 6.2 Deep water harvesting contour trench for moisture stress areas

In addition, zai pit technology is another water harvesting technology suitable for areas with unpredictable rains and subsequent crop failure. Zai pit digging and planting pits with a diameter of at least 30 to 40 cm and 10 to 15 cm deep are recommended sizes. Similarly, zai pits are spaced 70 to 80 cm apart, resulting in

around 10,000 pits per hectare. In order to trap moisture or runoff water in the area, zai pits are constructed or dug in staggered rows that are perpendicular to the slope (see Fig 6.4).

The earth dug out of the pit is piled up to form a small ridge around the rim, which captures water. A couple of handfuls of organic fertilizer or compost are put into each pit and they are normally made in the dry season before the first rains start.



Fig 6.3 Design and construction of zai pit as an effective moisture harvesting technique

The pits are made immediately after the rainy season, when the soil is still moist and the weather is not too hot. If the pits are in place early in the dry season, they act as traps during the windy period, retaining rich dust carried by the wind-blown organic matter.

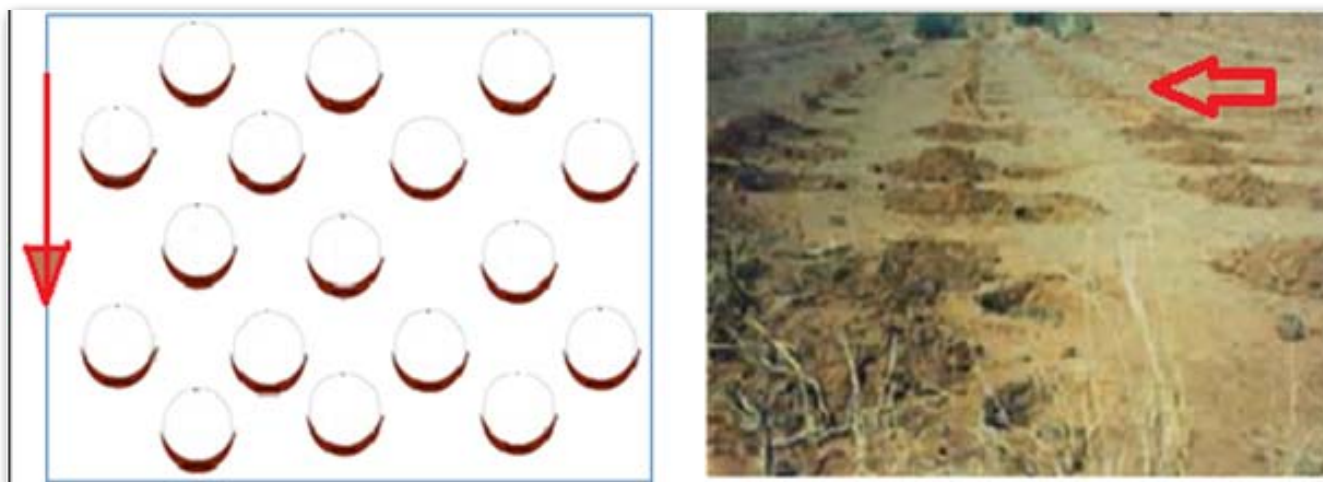

Fig 6.4 Staggered design and construction of zai pits in moisture stress area

The arrangement of zai pits in staggered rows ensures the most efficient collection of rainwater and slows the flow of water over the surface. The zai technique concentrates and conserves nutrients and water near the roots of the plants grown in them. The application of organic fertilizer directly around the plants is an economical use of a factor of production to which most farmers have limited access. This also reactivates biological activity, increases fertility and loosens the soil. Zai pits are used on marginal or degraded land

that is no longer cultivated, such as low-gradient pediments and land with encrusted soil in areas with rainfall levels of less than 800 mm a year. Zai pits are not recommended for sandy soils, as they are not stable when dug in this type of soil, or for valley bottoms, where they risk being flooded. Zai planting pits are particularly useful in areas where land-use pressure is high, as they permit the rehabilitation of unproductive land for farming. From the point of view of climate change adaptation, zai planting is particularly useful in areas with erratic or low rainfall, as it prevents the loss of water. Similarly, as the fertilizer is placed inside the pits, it is not washed away by heavy rain. The planting pits are re-dug every two years. The arrangement of the pits in staggered rows ensures the most efficient collection of rainwater and slows the flow of water over the surface.



Fig 6.5 Effective and integrated moisture harvesting technique in arid and semi-arid areas

6.3 Technical Challenges

The zai technique requires high labour input and trained workers. It is estimated that between 40 and 60 man-days per hectare are required, depending on the density of the pits, which is around 10,000 pits per hectare. There is a mechanized system for making the pits, using a special animal-drawn plough, which considerably reduces the number of man-days required to 7 person-days/hectare. There is, however, little literature available on experiences using this mechanized technique.

Zai planting pits are not recommended for light soils, as they fill in too quickly. The use of light soil as fertilizer can cause scorching. Owing to its high nitrogen content, this type of fertilizer is not very effective in improving the physical properties of the soil. Fertilizer that is not properly decomposed (raw litter) attracts harmful insects and reduces the availability of nutrients for crops, which suffer from a lack of nitrogen, phosphorus and other nutrients.

6.4 Sustainability Factors for Zai Planting

Zai planting pits are techniques used to reclaim abandoned land. If the pits are prepared each year or once every two years, soil fertility is restored, and the crop cycle can be resumed. The application of organic fertilizer in sufficient quantities enables the plot to be cultivated sustainably. After five years, it can be farmed in the normal way. Covering extensive areas with zai planting pits requires a high level of community mobilization and effective organization and logistics. Apart from this, the technique is very simple to implement and easy to master by the farmers. When constructing zai pits the rows should be made perpendicular to the slope; the pits should be dug in staggered rows; ridges should be formed on the downhill side; a handful of organic fertilizer amounting to around 3 tons/ha may be applied every two years; and for manure, transportation of about 30 cartloads of manure may be required.

6.5 Operation and Maintenance

Due to their simple construction, only basic materials are needed for building contour pits and trenches, such as stakes, shovels, pick axe, digging hoe, and crowbars. For reaching best outputs, sediment should be removed from the bunds and be reapplied to the field uphill the trench from time to time. Berms may need more frequent repairing as long as vegetation has not been established to stabilize soil. Field trenches are suitable for most soils and rainfall conditions and their design may be adapted to different rainfall conditions. The advantages of pits and trenches are that they are applicable to all soils and rainfall conditions, prevent soil degradation and erosion, enhance surface water infiltration and soil moisture, help reduce flood hazards, and comparably, their construction is simple and requires only basic construction materials.

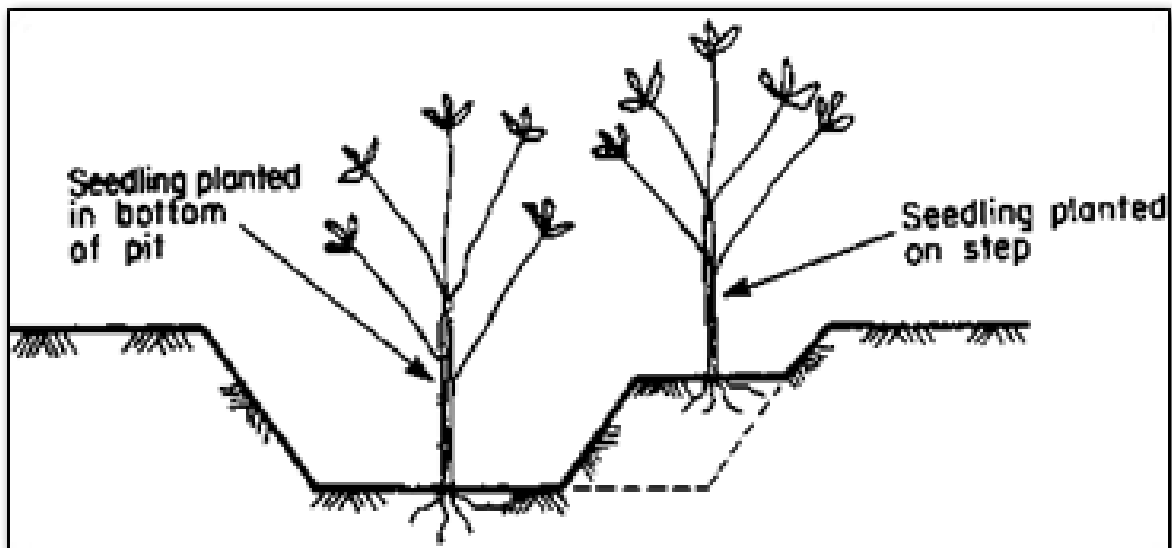

Fig 6.6 Planting position of seedlings in pits

Design and Construction of Negarim Micro-Basin

7.1 Description

Negarim micro-catchments are diamond-shaped basins surrounded by small earth bunds with an infiltration pit in the lowest corner of each basin. Runoff water is collected from within the basin and stored in the infiltration pit. The micro-catchments techniques are mainly used for growing high value trees or bushes. Negarim micro-catchment technique is appropriate for small-scale tree planting in any area which has a moisture deficit. Besides harvesting water for the trees or plants, negarim micro-catchment simultaneously conserves soil, and it is neat and precise, and relatively easy to construct. Negarim micro-catchments water harvesting techniques are suitable and mainly used for tree growing in arid and semi-arid areas where rainfall can be as low as 150 mm per annum, and minimum soil depth is 1.5 -2 m (to ensure adequate root development and storage of harvested water) and slope of the land is from flat up to 5%.



Fig 7.1 Construction of basins

Each negarim micro-catchment consists of a catchment area and an infiltration pit of cultivated area. The shape of each unit is normally squared, but the appearance is of a network of diamond shapes with infiltration pits in the lowest corners (see Fig 7.2).

However, though negarim micro-catchments water harvesting techniques are well suited for hand construction, they cannot easily be mechanized. Therefore, once the trees are planted, it is not possible to operate and cultivate with machines between these tree lines. The area of each unit of micro-catchment of the basin is usually determined on the basis of estimated water requirement of each plant. Depending on the species of trees to be planted, the size of the micro-catchments (per unit) normally ranges between 10 m² and 100 m², but larger sizes are also feasible, particularly when more than one tree is planted within one unit. The height of

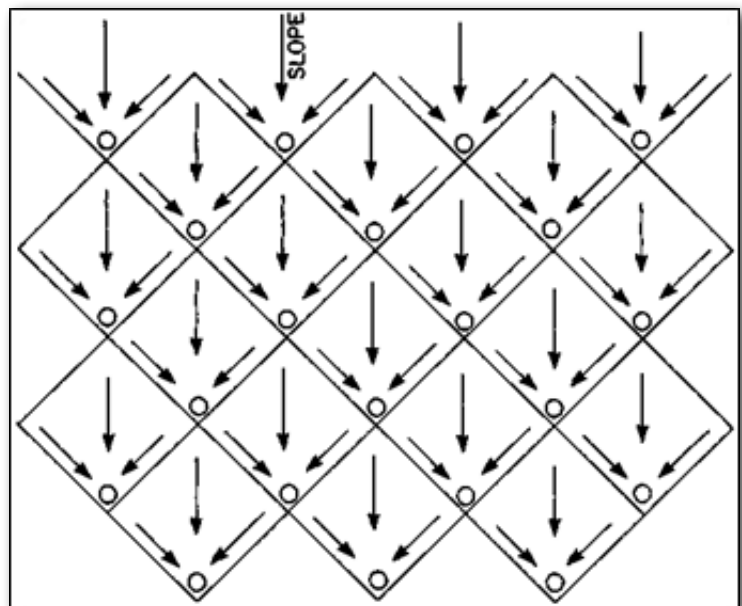

Fig 7.2 Staggered design of Negarims

the bund primarily depends on the prevailing ground slope and the selected size of the micro-catchment. It is, in fact, recommended to construct bunds with a height of at least 25 cm in order to avoid the risk of over-topping and subsequent damage. Where the ground slope exceeds 2%, the bund height near the infiltration pit must be increased. The top of the bund should be at least 25 cm wide and side slopes should be at least in the range of 1:1 in order to reduce soil erosion during rainstorms. The excavated soil from the pit should be used for construction of the bunds, and whenever possible, the bunds should be provided with a grass cover since this is the best protection against erosion.

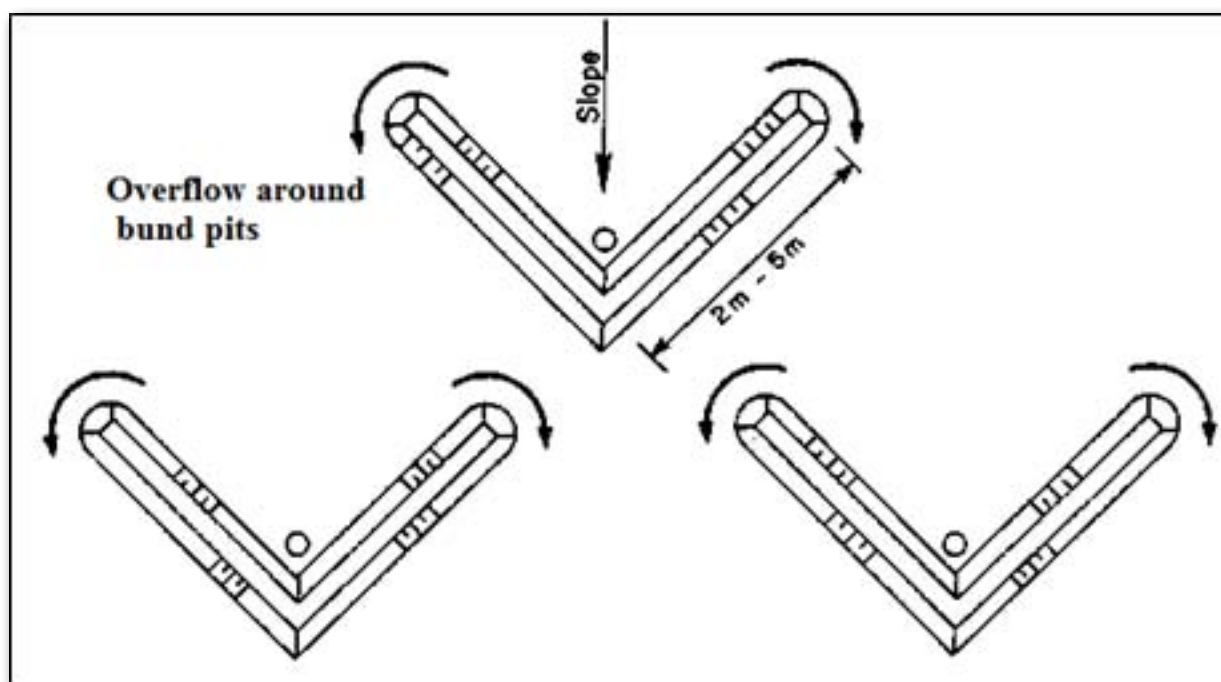

Fig 7.3 Staggered design of V-shaped Negarims

In order to avoid water losses through deep percolation and to reduce the workload for excavation, the maximum depth of the infiltration pit should not exceed 40 cm. When a diversion ditch is required, additional earthworks of 62.5 m³ per 100 m length of ditch will be needed. As a common design variation, the micro-catchments can be built as single, open-ended structures in "V" or semi-circular shape (see Fig 7.3). The main advantage is that surplus water can flow around the tips of the bunds and will not escape, however, the storage capacity is less than that of a closed system. These types of bunds are particularly useful on broken terrain, and for small numbers of trees around homesteads.

7.2 Layout and Construction of Negarim Micro-catchment

Step 1: The first step is to find a contour line. This can be done by using a line level or a water tube level. Since natural contours are often not smooth, it will be necessary to even out the contours so that finally a straight line is obtained. The first line at the top of the block is marked. If the topography is very uneven, separate smaller blocks of micro-catchments should be considered (see Fig 7.4).

Step 2: By means of a tape measure, the tips of the bunds are now marked along the "straightened contour". The first line will be open-ended. The distance between the tips (a-b) depends on the selected catchment size.

Step 3: A piece of string as long as the side length of the catchment (5 m for a 5 m x 5 m micro-catchment) is held at one tip (a) and a second string of the same length at the other tip (b). They will exactly meet at the apex (c). The apex is now marked with a peg and the catchment sides (a-c) and (b-c) marked on the ground alongside the strings with a hoe. This procedure will be repeated until all bund alignments in the first row have been determined.

Step 4: The next row of micro-catchments can now be staked out. The apexes of the bunds of the upper row will be the tips for the second row and the corresponding apexes will be found according to Step 3. When the second row of micro-catchments has been marked, repeat the same procedure for the third row, etc. The final result will be a block of diamond-shaped micro-catchments, with the first row which is open at the upslope end.

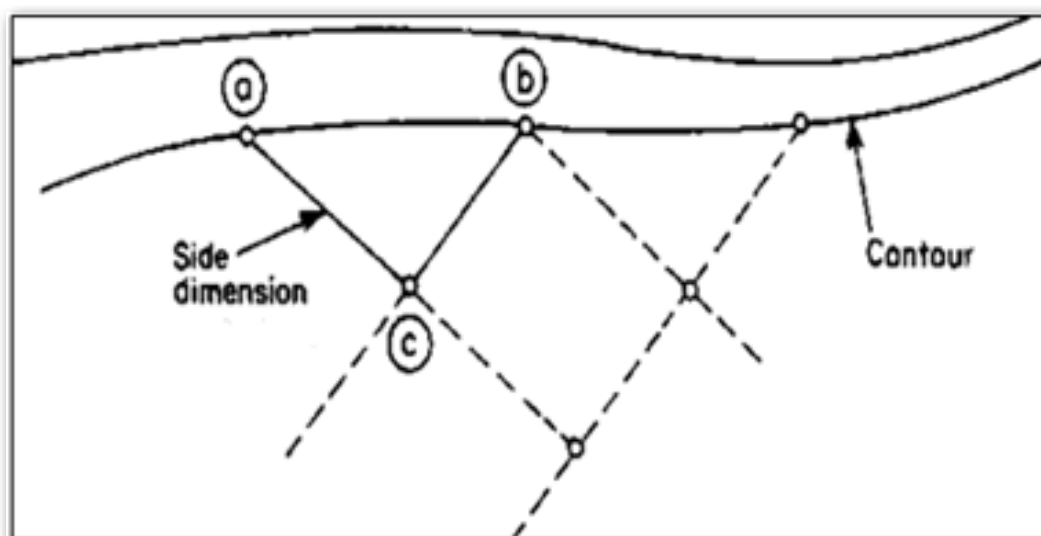

Fig 7.4 Steps in laying out staggered Negarims

Step 5: The size of the infiltration pit is staked out and the pit is excavated - leaving a small step towards the back on which the seedling will be planted.

Step 6: Before constructing the bunds, the area within the micro-catchments should be cleared of all vegetation. The bunds should then be constructed in two layers. The excavated material from the pit is used to form the bund. The bunds should be compacted during construction. Before compaction, the soil should be wetted wherever possible. Compaction may be done by foot or with a barrel filled with sand or water. To ensure a uniform height of the bund, a string should be fixed at the beginning and the end of each bund alignment and be adjusted above ground according to the selected bund height.

Step 7: A diversion ditch should be provided above the block of micro-catchments if there is a risk of damage by runoff from upslope of the block. The diversion ditch should be aligned in a 0.25% slope and in most cases a depth of 50 cm and a width of 1.0-1.5 m will be sufficient. The soil is deposited downslope. The diversion ditch should be constructed first to prevent damage in case a rainstorm occurs during construction of the micro-catchments (see Fig 7.5).

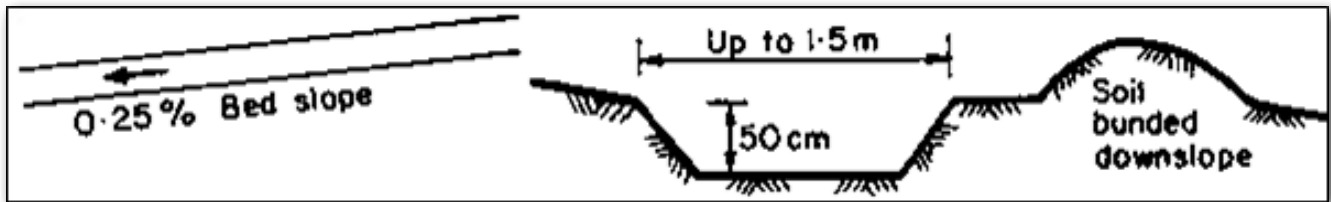

Fig 7.5 Design dimension for a small diversion ditch

7.3 Maintenance and Husbandry

Maintenance will be required for repair of damages to bunds, which may occur if storms are heavy soon after construction when the bunds are not yet fully consolidated. The site should be inspected after each significant rainfall as breakages can have a "domino" effect if left unrepaired.

Tree seedlings of at least 30 cm height should be planted immediately after the first rain of the season. It is recommended that two seedlings are planted in each micro-catchment - one in the bottom of the pit (which would survive even in a dry year) and one on a step at the back of the pit. If both plants survive, the weaker can be removed after the beginning of the second season. For some species, seeds can be planted directly. This eliminates the cost of a nursery.

Manure or compost should be applied to the planting pit to improve fertility and water-holding capacity. If grasses and herbs are allowed to develop in the catchment area, the runoff will be reduced to some extent. However, the fodder obtained gives a rapid return on the investment in construction. Regular weeding is necessary in the vicinity of the planting pit.

7.4 Socio-economic Considerations

Negarim micro-catchments have been developed in arid and semi-arid areas for the production of fruit trees, but the returns on investment are not always positive. It is not a cheap technique, bearing in mind that one person-day is required to build (on average) two units, and costs per unit rise considerably as the micro-catchment size increases.

It is essential that the costs are balanced against the potential benefits. In the case of multipurpose trees in arid and semi-arid areas, for several years the main benefit will be the soil conservation effect and grass for fodder until the trees become productive. Negarim micro-catchments are appropriate both in village afforestation blocks, and/or around homesteads where a few open-ended "V" shaped micro-catchments provide shade or support amenity trees.

Chapter 8

Design and Construction of Bench Terraces

8.1 Description

Bench terraces consist of a series of level or nearly level platforms built along the contour lines at suitable intervals. Bench terraces are suitable for slope land farms with a considerable depth of soil, and for farms which are being intensively cultivated. Because a large amount of cutting and filling is required per unit area, bench terraces may not be the optimum practice on easily eroded soils. Bench terraces are artificial land terraces with flat top and often nearly vertical side and used especially in series to convert steep slopes into arable land. These terraces are a series of level or virtually level strips running along the contour or across the slope at vertical intervals, supported by steep banks or risers.

The main objectives of bench terraces are to reduce run-off or its velocity and to minimize soil erosion; and to promote intensive land use and permanent agriculture on slopes and reduce shifting cultivation, conserve soil moisture and fertility and to facilitate modern cropping operations, such as irrigation on sloping lands. Bench terraces reduce erosion damage by capturing or slowing down surface runoff and directing it to a stable outlet at a velocity that minimizes erosion. On long, steep slopes that have a water erosion problem or where it is anticipated that water erosion will be a problem, benches are particularly effective. These terraces trap and retain sediments from the slope above, and the re-vegetation process on bare slopes can be enhanced. Moisture is held better than smooth slopes, and the sediment loading of surface runoff is minimized. These terraces may be used on new slopes to minimize erosion and can be suitable for slopes in soils and soft rock that can be excavated by ripping.

8.2 Limitations

Benches should not be constructed on slopes or cuts:

- ♣ With sandy or rocky soils, non-cohesive or highly erodible soils, or decomposing rock including other depositional materials.
- ♣ With soft-rock laminations in thin layers oriented so that the strike is approximately parallel to the slope face and the dip approximates the staked slope line.
- ♣ Benches terraces may cause sloughing if too much water infiltrates in the soil and are effective only where suitable runoff outlets are available.
- ♣ Avoid benching, if possible, in areas where there is potential for rock-fall slide problems.

8.3 Design Parameters

- ◆ The design of benches should be determined by an experienced expert and engineering survey and layout.
- ◆ The upper step should begin immediately below the top of the cut or fill. Continue constructing terraces or benches down to the toe of the slope.
- ◆ Terraces or benches should have approximately vertical back slopes and may vary from 0.6 to 1.22 m vertically. The tread (level area) should be approximately horizontal but may be parallel to the roadway grade if it is less than 4%.
- ◆ Slopes 2H:1V or steeper may be stair-stepped with benches at sufficient width to retain sediment eroded from the slope above.

- ◆ The benches must be designed with adequate outlets, such as a grassed waterway, vegetated area, or other suitable and safe outlet. Slope drains may be needed to convey excess surface runoff from the terraces or benches to the toe of the slope without causing erosion. Analysis of the local site conditions should determine by the needed outlets.
- ◆ Benches may be constructed with liners to carry water to the outlet.
- ◆ Interceptor ditches may be needed at the top of the slope to prevent or reduce the surface water from running down the slope face.
- ◆ Stabilize or re-vegetate the slope with methods applicable to the particular site.

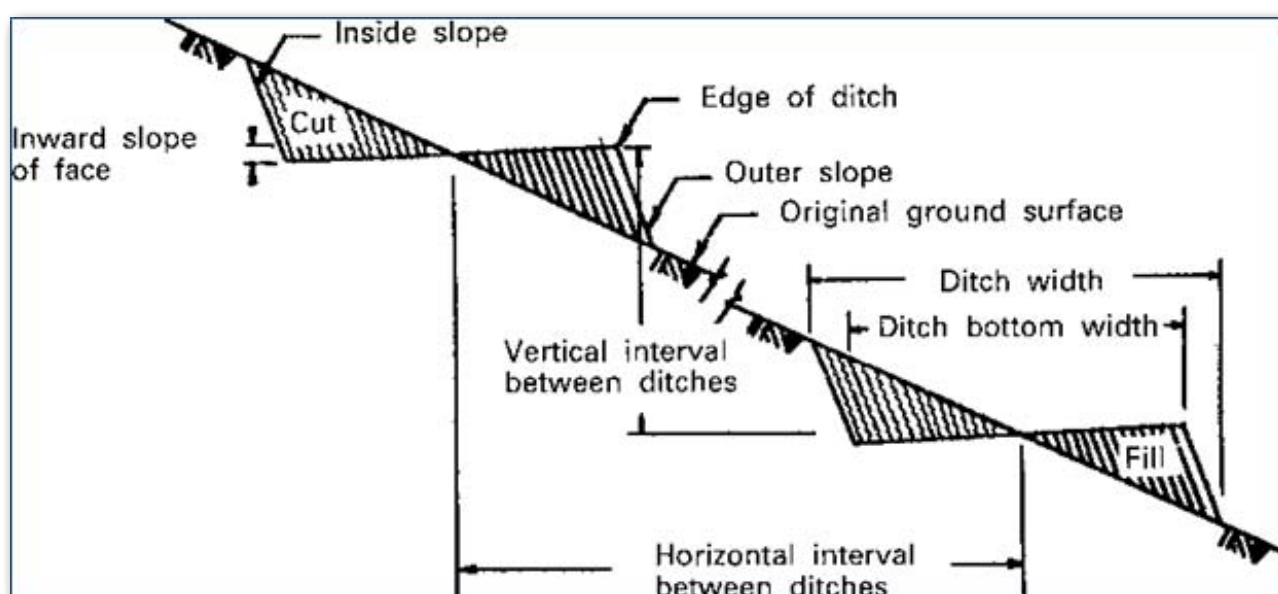

Fig 8.1 Cross-section of a bench terrace

8.4 Types of Bench Terraces and Criteria for Selection

There are two main types of bench terraces: (1) Irrigation or level bench terraces, which are used where crops, such as cereals, eg rice, need impounding water or flood irrigation; and (2) Upland bench terraces, which are used mostly for rain-fed crops or crops which only require irrigation during the dry season. They are generally sloped for drainage. In humid areas/regions, reverse sloped type benches are used, and in arid or semi-arid areas/regions, outward-sloped type benches are used (see Fig 8.3).

Locations and conditions for use: Generally speaking, bench terraces are particularly suitable in areas or macro conditions with severe erosion hazards; areas with small holdings and a dense population; areas where there are food/land shortages or high unemployment rates; and in areas where crops require impounding water or flood irrigation. For micro or site conditions, bench terraces are suitable in the following cases: (1) where there are relatively deep soils; (2) on slopes not exceeding 25 degrees or 47%; and (3) on sites which are not dissected by gullies and not too stony.

Bench terraces are much more cost-effective if there is potential for growing high-value crops, irrigation and mechanized farming.

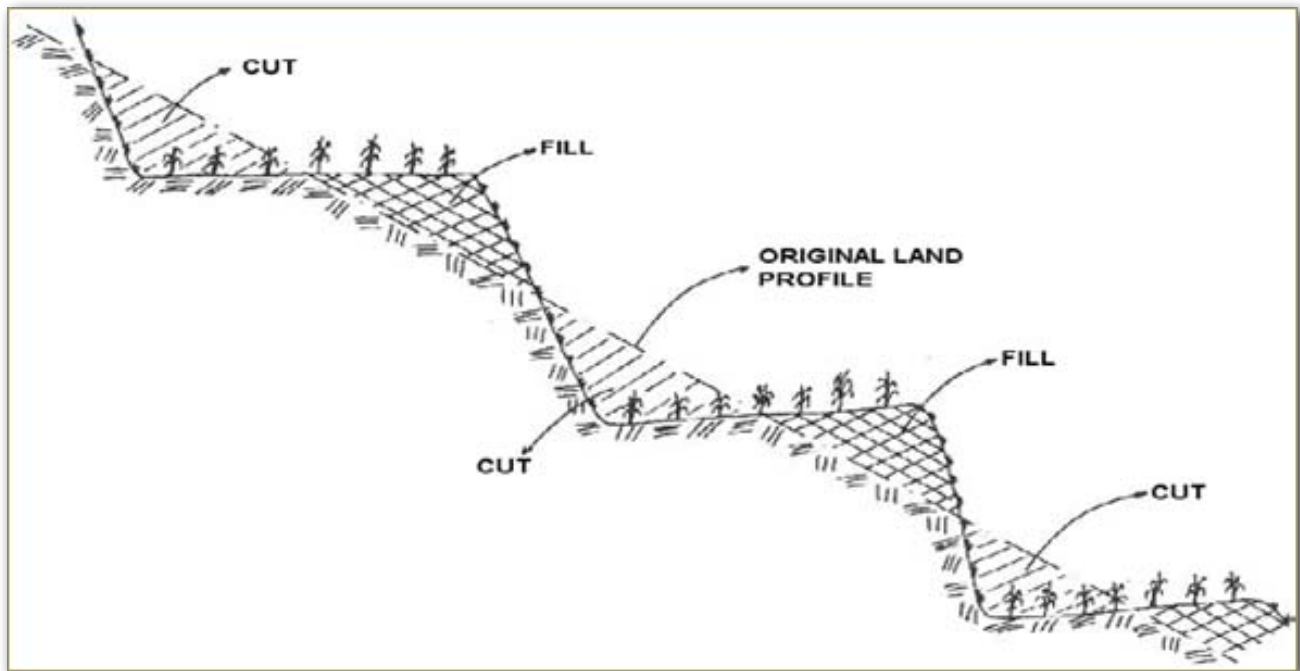

Fig 8.2 Design and construction of level bench terraces

8.5 Design Specifications and Construction Guides

1. **Length:** The length of a bench terrace is limited by the size and shape of the field, the degree of dissections and the permeability and erodibility of the soil. The longer the terraces, the more efficient they will be, but it should be borne in mind that long terraces cause accelerated runoff and greater erosion hazards. A maximum of 100 m in one draining direction is recommended for typical conditions in a humid tropical climate. The length can be slightly increased in arid and semi-arid areas or regions.
2. **Width:** The width of the bench (flat part) is determined by soil depth, crop requirements, and tools to be used for cultivation, the land owner's preferences and available resources. The wider the bench, the more cut and fill needed and hence the higher is the cost. The optimum width for labour intensive (handmade and manual-cultivated) terraces range from 2.5 m to 5 m; and for machine built and tractor-cultivated terraces, the range is from 3.5 m to 8 m.
3. **Gradients:** Horizontal gradients range from 0.5 to 1% depending on the climate and soils. For example, in humid areas and on clay soils, 1% is safe for draining the runoff. In arid or semi-arid areas, the horizontal gradients should be less than 0.5%. The reverse grade for a reverse-sloped terrace is 5% while the outward grade for an outward sloped terrace is 3%.
4. **Slope limit:** If soil depths are adequate, handmade bench terraces should be from 12% to 47% slopes (or from 7 to 25 degrees) and for machine-built terraces, slopes should be from 12% to 36% (or from 7 to 20 degrees). If the soil depths are not adequate for bench terraces, hillside ditches or other types of rehabilitation measures should be used. Bench terraces are not recommended for slopes below 12% (or 7 degrees), but broad-base terraces and other simple conservation measures should be used instead.

5. Risers and riser slopes: Riser material can be either compacted earth, protected with grass, or rocks. In order to ensure easy maintenance, terrace riser height should not exceed 2 m, after allowing for settling, especially for earth risers. Riser slopes are calculated by the ratio of the horizontal distance to the vertical rise as follows (see Fig 8.3):

- * Hand-made benches with earth material: 0.75:1 (Wb:Hr)
- * Hand-made benches with rocks: 0.5:1 (or 1:2)
- * Machine-built benches with earth material: 1:1

For level terraces, the following formula is used for determining the riser height (for reverse-sloped terraces see Fig 8.1).

- » $Hr = VI + DH$
- » Hr: height of riser in m.
- » VI: vertical interval in m.
- » DH: dyke height that is 15 or 20 cm.

6. Vertical interval: The vertical interval (VI) is the difference in height between two succeeding terraces. It gives the height of the terrace; provides basic data for calculating the cross-section and volume of soil to be cut and filled, and is used as a guide for laying out and staking on the ground. The vertical interval (VI) is determined using the following formula:

$$VI = \frac{S * Wb}{100 - (S*U)}$$

- ◆ VI: Vertical interval in m
- ◆ S: Slope in percent (%)
- ◆ Wb: Width of bench (flat strip) in m
- ◆ U: Slope of riser (using value 1 for machine-built terraces, 0.75 for hand-made earth risers and 0.5 for rock risers).

Example: Calculate the vertical interval (VI) of 4 metres wide hand-made benches on a 30% slope with hand-made earth risers of 0.75.

$$VI = \frac{S * Wb}{100 - (S*U)} = \frac{30 * 4}{100 - (30*0.75)} = 1.55m$$

(vii) **Depth of Cut:** The depth of cut can be calculated according to the following formula:

$$D = \frac{Wb}{2} \tan \phi \text{ (for level terraces)}$$

$$D = \frac{Wb}{2} \tan \phi + \frac{RH}{2} \text{ (for reverse-sloped terraces)}$$

$$D = \frac{Wb}{2} \tan \phi - \frac{OH}{2} \text{ (for outward-sloped terraces)}$$

D: depth of cut in m.
 Wb: width of bench in m
 tan ϕ : Tangent of the slope angle.
 RH: reverse height
 OH: Outward height

Example: Calculate the depth of cut for a 4 m wide reverse-sloped bench terrace on a 15 degree slope:

$$D = \frac{Wb}{2} \tan \phi + \frac{RH}{2} = \frac{4}{2} * 0.26795 + \frac{0.2}{2} = 0.64\text{m}$$

Where RH = 4 x 0.05 = 0.2

(viii) Net Area: This is the area in benches or flat strips which is used for cultivation. The net area can be calculated by using the following formula:

$$A = \frac{10000 * Wb}{Wt}$$

Where A is net area of benches per ha in m²

Wt: width of terraces (the sum of the width of the bench and the width of the riser), in m

Wb: width of the bench, in m

When calculating the net area of level terraces, the dyke width should be subtracted.

(ix) Cross section: The cross-section can be computed by the following formula:

$$C_A = \frac{Wb * Hr}{8}$$

C_A: Cross-sectional area of the cut triangle, in m²

Wb: Width of bench, in m

Hr: Height of riser, in m

The linear length of terraces per hectare can be calculated by the following equation:

$$L = \frac{10,000}{Wt}$$

The linear length of terraces per acre can be calculated by the following equation:

$$L = \frac{43,560}{Wt}$$

L: Linear length of terraces in one hectare, in m.

Wt: Width of terrace, in m (where $W_t = W_b + W_r$).

The volume (V) can be calculated by multiplying the linear length (L) by the cross-sectional area (C_A)

$V = L * C_A$.) (For calculating linear length, see Fig 8.2)

When calculating the volume to be cut and filled it should be noted that only one cross-section is used. This is because the same cross-section is moving downslope to form a terrace. For level terraces, the following formulas should be used for computing cross-sectional area:

$$C_A = \frac{W_b * VI}{8} + DC$$

C : cross-section, in square m

Wb: width of bench, in m

VI : vertical interval, in m

DC: Dyke cross-section, in square m (or m^2)

For outward-sloped terrace a modification of the riser height (Hr) is required for calculating cross-section and volume as follows:

$$H_r = VI - OH$$

Hr: Height of riser

VI: Vertical interval

OH: Outward height (equals width of bench multiplied by 0.03)

8.6 Diagrams of Bench Terrace

Figure 8.3 shows a diagram of reverse-sloped bench terraces and terminology, together with a set of formulae for computing the specifications of the terraces (Table 8.1). These step-by-step computations, using only simple mathematics, should present no difficulties to field technicians or experts. The computations are for reverse-sloped bench terraces, but they can be applied to other types of bench terraces with only minor modifications. For level bench terraces, the major differences are their dykes and the lack of gradients.

Construct terraces and benches using equipment that is capable of meeting the specifications established in the plans and drain to a stabilized or safe area. In cut slopes, begin the terrace or bench construction at the top of the slope and work downward. Remove the loose material that collects at the end of terraces or benches and blend the ends of each terrace or bench into the natural ground surface. If the rock encountered is too hard to rip (within a cut), blend the terraces or benches into the rock. Scale the benched and terraced slopes to remove rock that may fall into the roadway ditch or onto the roadway. Install interceptor ditches prior to beginning the construction of the cut section.

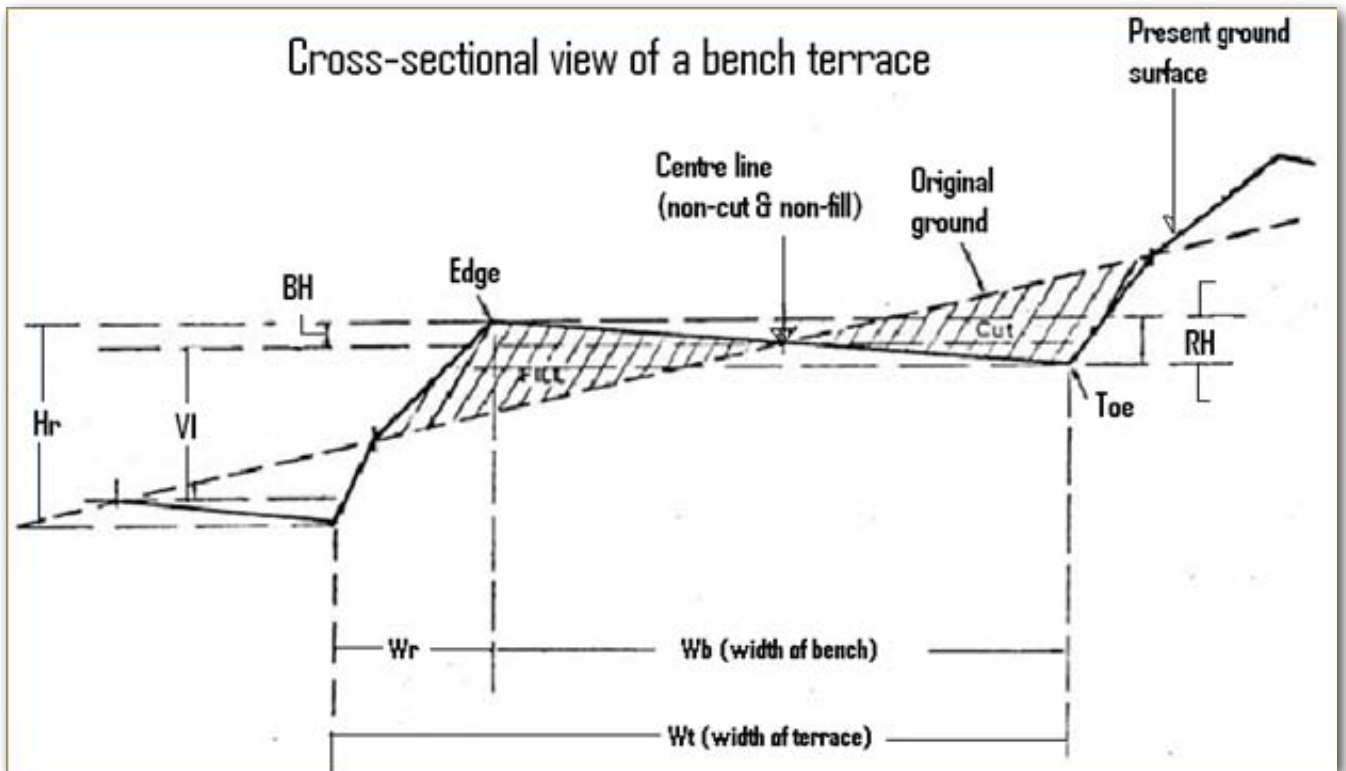

Fig 8.3 Cross-sectional view of a bench terrace

Table 8.1 Summary of formulae for computing the specifications of the terraces

1.	Vertical Interval (VI)	$VI = \frac{S * Wb}{100 - (S*U)}$
2.	Depth of cut (D)	$D = \frac{Wb}{2} \tan \phi \text{ (for level terraces)}$
3.	Depth of cut (D)	$D = \frac{Wb}{2} \tan \phi + \frac{RH}{2} \text{ (reverse slope)}$
4.	Depth of cut (D)	$D = \frac{Wb}{2} \tan \phi - \frac{OH}{2} \text{ (outward slope)}$
5.	Revers Height (RH)	$RH = Wb * 0.05$
6.	Height of Riser (HR)	$HR = VI + RH$
7.	Width of riser (Wr)	$Wr = Hr * U$
8.	Width of terrace (Wt)	$Wt = Wb + Wr$
9.	Linear length (L)	$L = \frac{43,560}{Wt} \text{ (per acre)}$
10.	Linear length (L)	$L = \frac{10,000}{Wt} \text{ (per ha)}$
11.	Net Area of bench (A)	$A = L * Wb$
12.	Percent of bench (Pb %)	$Pb = \frac{43,560}{Wt} * 100 \text{ (per acre)}$
13.	Percent of bench (Pb %)	$Pb = \frac{10,000}{Wt} * 100 \text{ (per ha)}$
14.	Cross-sectional Area (C _A)	$C_A = \frac{Wb * Hr}{8}$
15.	Volume of cut and fill (V)	$V = L * C_A = L * \frac{Wb * Hr}{8}$

8.7 Nomograph for Quick Reference

Figure 8.3 is a nomograph for quick reference. It shows the volumes of soil to be cut and filled and the width limit for both hand-made and machine-built bench terraces of the reverse-sloped type.

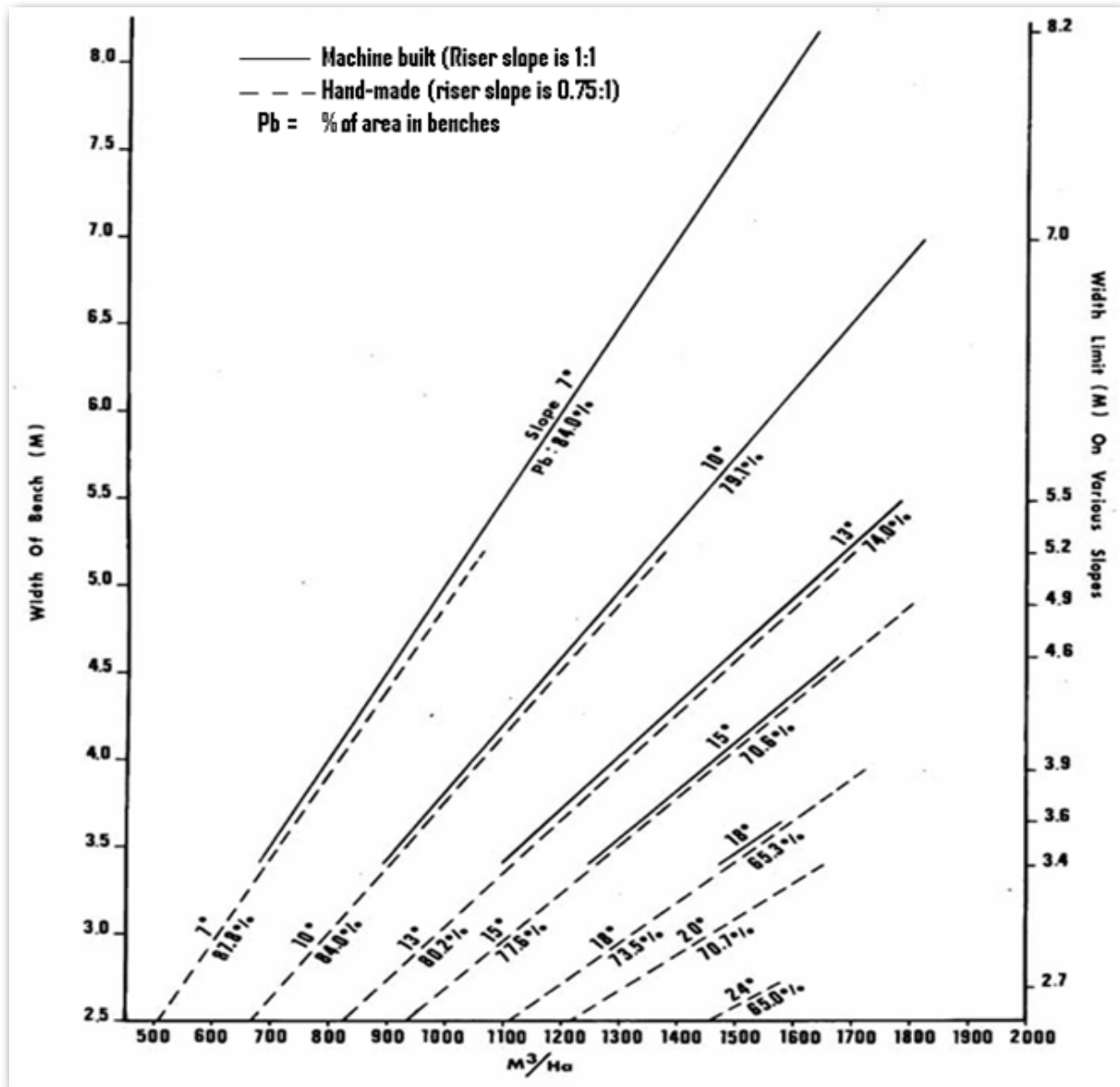

Fig 8.3 Volumes of soil to be cut & filled per hectare for reverse-sloped bench terrace

8.8 Layout and Surveying Procedures

The layout of terraces should include an examination of the site's physical conditions such as slope, soil depth, texture, erosion, presence of rocks, wetness, vegetation cover and present land use. The layout design should include specifications of the terraces (or treatments), sites and types of waterways, sites of roads and other farm installation needs. Human factors such as the farmers' plans and resources, labour conditions, and the tools to be used, must also be considered

8.9 Surveying of Bench Terraces and Preparatory Work

This entails clearing the area, preparing survey equipment, stakes, colour ribbons or markers, and deciding on survey methods and sequences.

A) Equipment

The equipment usually consists of:

- * dumpy level, abney level or A-level or A-frame;
- * measuring tape and rod;
- * soil auger.

B) Basic techniques

- * For level bench terraces: use contouring or levelling techniques.
- * For upland bench terraces: use graded-contouring techniques

C) Special Techniques

1. **Setting of base-line:** An up-and-down base-line should be set at the site along a representative slope.
2. **Use of centre-line method:** When specification tables are not available, a quick calculation of the VI can be made in the field. Use a level to determine and stake the VI of the terraces along the base line. This should be followed by graded contouring or levelling surveys according to the type of terrace to be built.

After staking out all the contours or graded contours, add one line of marked stakes in between them. This line serves as the bottom line of the upper terrace and the top line of the lower one. Continue adding stakes so as to cover the whole area. A top line should be added to the first terrace on the upward slope, and a bottom line to the last terrace on the downward slope. This method is recommended for hand-made terraces where centre-lines should be kept and observed as non-cut and non-fill lines.

3. **Use of two-line method:** Design details can be readily obtained when a set of specification tables are available. The base line should be staked out with the width of the terrace (W_t), using a tape. A contour or graded contour line should be run from each stake until the whole area is covered. These lines serve as the bottom lines of the upper terraces as well as the top lines of the succeeding terraces. This method is recommended for terrace construction using mechanical power, as any centre-lines will obstruct the construction operation and should be omitted.
4. The stakes should be streamlined if there are sharp turns and narrow bottlenecks as these will interfere with future operations. Streamlining the stakes entails extra cuts or fills but is worthwhile in the long run

Marking Stakes: Each contour line of stakes should be marked with a different colour ribbon or paint in order to avoid confusion during construction; e.g. centre lines can be in red, and side lines in yellow or green, etc.

Construction Methods: The cut and fill of the terraces should be done gradually and at an equal pace so that there is neither an excess nor a lack of soil. This principle applies regardless of what kinds of tools are used for the operation.

Manual Labour: The terrace must be built when the soil is neither too dry nor too wet. Start building the terrace from the top of a hill and proceed downslope. It will not be washed away in the case of heavy rain. However, when topsoil or upper area treatment or preservation is carried out or ensured, it is necessary to start building from the bottom of the hill upwards. In this case, temporary protection measures should be undertaken. If the upper catchment area is not treated, construction of cut off drain is an alternative or necessary to protect the terraces from damage by the runoff that may come from the upper and untreated areas.

Tie a cord or rope around the stakes to mark each constructed terrace in sequence. The initial cut must be made immediately below the top stakes while the fill work should be started against the bottom stakes. This is done in order to ensure that the correct grade is attained without overcutting. Sometimes, rocks or clods of earth can be placed along the bottom line of the stakes to serve as a foundation before filling. During the filling operation, the soil should be compacted firmly by a beater every 15 cm layer. If the layer of soil fill is thick, the compacting process becomes difficult. Terraces which go across existing depression areas should be built particularly strong. The edge of a terrace should be built a little higher than planned because of settling. The rate of settling may be as high as 10% of the depth of the fill.

Both the reverse and horizontal grades should be checked by a level during construction work and corrections must be made promptly wherever necessary. The slope of the riser should be shaped to 0.75:1. Waterway shaping should be commenced only after the terraces are cut. Make sure all the terrace outlets are higher than the waterway bottom.

8.10 Topsoil Treatment or Preservation

Bench terraces usually expose the infertile subsoil and this can result in lower production unless some prevention or improvement measures are undertaken. One such measure is topsoil treatment or preservation. When fertile topsoil exists, topsoil treatment is always worthwhile. Two alternative methods are: (1) the terraces should be built from the bottom of the slope upwards. After the bottom terrace is roughly cut, the topsoil from the slope above is then pulled down to the lower bench and spread on its surface. Repeat this procedure for the next terrace up the slope and proceed uphill in this way until the top terrace is built. Of course, the top terrace will not have topsoil unless it is obtained from another place; (2) the second method is to push the topsoil off horizontally to the next section before cutting the terrace. The topsoil should be pushed back when the bench is completed. For hand-made terraces, the topsoil can be piled along the centre line provided that the bench is wide enough

Physical output (Manual labour): Generally-speaking, a person can cut and fill 3 to 4 cubic meter of earth during eight hours of supervised work, although output may vary depending on the type of soil and if rocks are present. If a terrace is wider than 4 m, output will be reduced because the transporting of the earth requires extra time. A team of 3 persons for narrow terraces and 4 persons for wider terraces is recommended for efficient terracing work. In the case of wider terraces, two persons should be employed for cutting, the third for compacting and consolidating the risers, and the fourth for transporting the dirt.

Cost and cost relations: Once the terracing volume per unit area is calculated with the formula illustrated in the previous section, the construction cost can be computed as follows:

$$C = \frac{V}{T} * R$$

C: Cost of constructing terraces

V: Volume of cut and fill

T: Output per person-day

R: Wage per person-day, etc.

For topsoil preservation, add 40 person-days per hectare for manual labour.

Cost relations: The cost of terracing per unit area depends on the following factors: slope, soil, width of bench, presence of rocks or tree stumps, and tools to be used for construction. The wider the bench (flat strip) the more costly it will be, even though the percentage of the bench remains the same. With a fixed width, the steeper the slope, the more expensive the terracing work will be.

8.11 Protection, Maintenance and Inspection

- ♣ Conduct close inspections during and after construction as per standard specifications.
- ♣ Periodic inspection and maintenance will be required based on post-construction site conditions.
- ♣ Make any repairs necessary to ensure the measure is operating properly.
- ♣ During the construction phase, maintenance of the terraces and benches will be the responsibility of the field technicians to ensure that these measures are properly functioning.
- ♣ Damaged benching and terracing areas shall be repaired immediately and reseeded as soon as possible. If excessive seepage or surface runoff is a problem, the seepage/runoff should be controlled with appropriate drainage facilities.
- ♣ Prompt action shall be taken as needed to ensure proper drainage and slope stability. Rills shall be prepared and damaged areas shall be reseeded as they develop.
- ♣ Substantial maintenance of the newly planted or seeded vegetation may be required.

New terraces should be protected at their risers and outlets and should be carefully maintained, especially during the first two years. After cutting a terrace, its riser should be shaped and planted with grass as soon as possible. Sod-forming or rhizome-type grasses are better than those of the tall or bunch-type. Although tall grasses may produce considerable forage for cattle, they require frequent cutting and attention. The rhizome-type of local grass has proved very successful in protecting risers. Stones, when available, can also be used to protect and support the risers. An additional protection method is hydro-seeding.

The outlet for drainage-type terraces is the point where the run-off leaves the terrace and goes into the waterway or safe outlets. Its gradient is usually steep and should be protected by sods of earth. A piece of rock, a brick, or a cement block, is sometimes needed to check the water flow on steeper channels. Similar checks on water flow are required for level bench terraces where the water falls from the higher terraces onto those below. A piece of rock should be placed on the lower terrace to dissipate the energy of the flowing water. Grasses should also be established on the area of the bench crossed by the waterway. Bench terraces require regular care and maintenance. If a small break is neglected, large-scale damage will result. Following is a list of maintenance work that should be carried out after heavy storms and cropping, especially in the first two to three years period.

Toe drains: The toe drains should be always open and properly graded; water must not be allowed to accumulate in any part of the terrace. All runoff should be allowed to collect at the toe drains for safe disposal to the protected waterway. Obstacles such as continuous mounds or beds must be removed at regular intervals to allow water to pass to the toe drain. Grasses and weeds should be removed from the benches. Correct gradients should be maintained and reshaped immediately after crops are harvested. Ploughing must be carried out with care so as not to destroy the toe drains and the grade.

Risers: Keep grasses growing well on the risers. Weeds which threaten the survival of the grasses should be cut back or uprooted. Grasses should not be allowed to grow too high. Any small break or fall from the riser must be repaired immediately. Cattle should not be allowed to trample on the risers or eat the grass. Runoff should not be allowed to flow over the risers on reverse-sloped terraces

Outlets for drainage types of terrace: The outlets should be checked to see whether they are adequately protected. Make sure that the water flows through the outlets instead of going around them. Any breaks must be repaired or maintained immediately.

Soil productivity: Deep ploughing, or sub-soiling is needed to improve the structure of the soils on the cut part of the bench terraces. Green manuring, or compost is needed in the initial period in order to increase soil fertility. Soil productivity should be maintained by means of proper crop rotation and the use of fertilizers.

Chapter 9

Grassed Waterways Design and Construction

9.1 Description

A grassed waterway is described as a natural or constructed channel shaped or graded to required dimensions, and established in suitable vegetation for the safe disposal of excess runoff water. Grassed waterways may be used alone or in combination with diversion terraces and other structures to discharge surface runoff as part of an erosion control system. Most land management plans for soil and water conservation must, to be effective, include grassed waterways as part of their design. The wide, shallow, sod-lined channels of these waterways safely dispose of surface water from heavy rains and prevent the formation of gullies.

Wherever surface runoff water from more than a few acres collects, a gully often forms. A grassed waterway is therefore needed to prevent the resulting erosion. If designed and constructed properly, grassed waterways can be crossed easily with farm equipment and can make farming more convenient.

The success of the total soil and water conservation program on farmland depends on the proper removal of excess surface runoff water through these waterways. The area needed for waterways should therefore be used for its intended purpose. When making a decision to construct a grassed waterway, the individual landowner or communities should first select the best time of the year for construction and grasses can be seeded right after construction, which is during the first rain.

9.2 Objective of Waterways

The main objective of grassed waterways is to convey excess runoff from terraces, diversions, or other water concentrations without causing erosion or flooding to reduce gully erosion, and to protect/improve water quality. Grassed waterways are therefore used to drain terraces or diversions, to dispose of water in road ditches, to stabilize a natural draw that is eroding, and to stabilize a natural draw to which additional runoff water is being added by contours or terraces. It is not considered a desirable practice to alter a conservation practice to modify an existing natural watercourse if it is currently carrying water and if the channel is not eroding.

9.3 Design Criteria and Requirements

Grassed waterways should be planned, designed, and constructed to comply with and meet all states of local conditions and design requirements, such as capacity, stability, width, side slopes, depth, drainage, outlets, and vegetative establishment.

1. **Capacity:** The minimum capacity shall convey the peak runoff expected from the 10-year frequency, 24-hour duration storm. The capacity shall be increased as needed to account for potential volume of sediment expected to accumulate in the waterway between planned maintenance activities. When the waterway slope is less than 1 percent, out-of-bank flow may be permitted if such flow will not cause excessive erosion. At a minimum, the design capacity shall remove the water before crops are damaged.

2. **Stability:** The soil and water conservation expert or field engineer should determine the minimum depth and width requirements for stability of the grassed waterway using the procedures in the soil conservation handbooks or other equivalent methods or references.
3. **Width:** It is necessary to keep the bottom width of trapezoidal waterways less than 30 meters unless multiple or divided waterways or other means are provided to control meandering of low flows.
4. **Side slopes:** Keep the side slopes flatter than a ratio of two horizontal to one vertical (2:1). The side slopes need to accommodate the equipment anticipated to be used for maintenance and tillage/harvesting equipment that will cross the waterway in the designed width.
5. **Depth:** The capacity of the waterway must be large enough so that the water surface of the waterway is below the water surface of the tributary channel, terrace, or diversion that flows into the waterway at design flow. It is also necessary to provide freeboard above the designed depth when flow must be contained to prevent damage and vegetation maximum expected retardance.
6. **Drainage:** Drainage is needed to help or keep vegetation established on sites having prolonged flows, high water tables, or seepage problems, including subsurface drains, underground outlets, stone centre waterways or other suitable measures in waterway designs.
7. **Outlets:** Provide a stable outlet with adequate capacity, which can be another vegetated channel, an earthen ditch, a grade-stabilization structure, filter strip or other suitable outlet.
8. **Vegetative Establishment:** Grassed waterways shall be vegetated according to the standard soil conservation practice criteria. Species selected for grassed waterways shall be suited to the current site conditions and intended uses, which shall have the capacity to achieve adequate density, height, and potential strength within an appropriate time frame to stabilize the waterway. Use mulch anchoring, nurse crop, rock, straw dikes, fabric checks, filter fences, or runoff diversion to protect the vegetation until it is established. Planting of close growing crops, like small grains or millet, on the contributing watershed prior to construction of the grassed waterway can also significantly reduce the flow through the waterway during its establishment.

9.4 Other Important Considerations

1. Establish an appropriate width of vegetation on one or both sides of the waterway or add other sediment control measures above the waterway (such as residue management to improve water quality and reduce sediment deposition in the waterway);
2. Increase the channel depth and/or designing areas of increased width or decreased slope to trap and store sediment to reduce the amount of sediment that leaves a field;
3. Be sure to provide for regular cleaning out of the waterway when trapping sediment in this manner;
4. Avoid areas where unsuitable subsurface, subsoil, and substratum material that limit plant growth that may be exposed during implementation of the practice;
5. Where areas cannot be avoided, seek recommendations from a soil scientist for ameliorating the condition or, if not feasible consider over-cutting the waterway and add topsoil over the cut area to facilitate vegetative establishment;

If trees and shrubs are incorporated, they should be retained or planted in the periphery of grassed waterways so that they do not interfere with hydraulic functions. Medium or tall bunch grasses and perennial forbs may also be planted along waterway margins to improve wildlife habitat. When possible, select species of vegetation that can serve multiple purposes, such as benefiting wildlife, while still meeting the basic criteria needed for providing a stable conveyance for run-off. Provide livestock and vehicle crossings as necessary to prevent damage to the waterway and its vegetation. To allow construction of a grassed waterway, an area must have enough soil to establish and maintain a stand of grass.

Grassed waterways are used in areas where added water conveyance capacity and vegetative protection are needed to control erosion resulting from concentrated runoff. If a stable natural outlet is not available, a physical structure is necessary, which may be equipped with tile drainage beneath the waterways. The extension adviser or development agent can give advice on the general application of the practice to a particular farmland situation. The district soil and water conservation experts should also be contacted about a specific conservation plan and can provide technical assistance for developing and implementing a conservation plan that incorporates the waterways into a total resource management system.

9.5 Sequence of Construction of Grassed Waterways

A grassed waterway should be built as part of a total soil and water conservation program. If land treatment measures are needed to control soil losses on the land draining into the grassed waterway, then these measures should be completed before the waterway is constructed. Otherwise the waterway will be damaged and may require excessive maintenance and reconstruction. If soil conservation terraces like cutoff drains are to be constructed to control upland erosion, then the grassed waterway may be used as an outlet for the water collected by the terrace system. In this case the grassed waterway should be built first so that when the soil conservation terraces are constructed, the outlet will already be available.

9.6 Design of Grassed Lined Waterways

The grassed waterway should be sized to carry the runoff resulting from the maximum 24-hour rainfall expected in a 10-year return period. To determine runoff volume, the field engineer or the soil and water conservation expert must know the hydrologic soil group that is dominant in the watershed to be drained by the waterway.

The land slope of the watershed in which the waterways are to be designed and constructed should be judged as being flat (0 - 2%), moderate (3-7%), or steep (over 7%). The land slope is that of the total land area contributing runoff to the waterway, but not the slope of the channel grade.

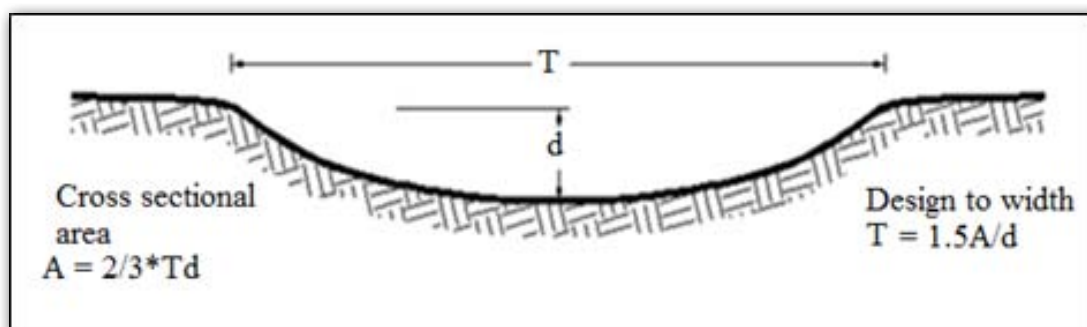

Fig 9.1: Cross-section of parabolic waterway

9.7 Shape and Dimension of Waterways

As a general layout, a natural drainage way should be used, if possible, to construct the waterway. Other desirable features to be considered are: (1) existing stable outlet for the drainage way; (2) soil and moisture conditions already favorable for growing grasses; and (3) enough depth in the drainage way to allow for outlets from terraces, diversions, or farm furrows at the grade of the constructed waterway without necessitating structures.

The size of the waterway depends on the peak flow, which in turn is proportional to the drainage area.

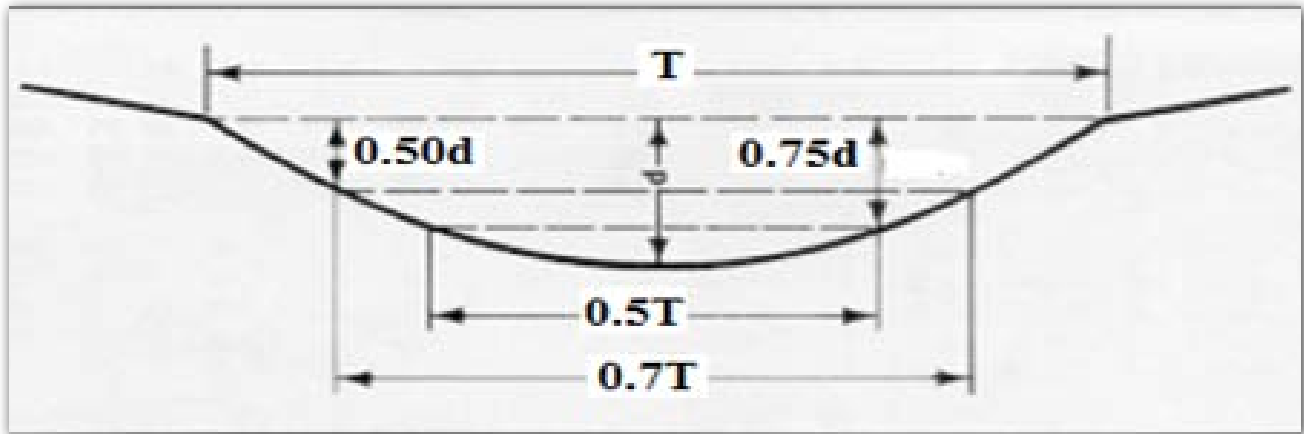

Fig 9.2: Configuration of a parabolic waterway

A field survey should be made along the course of the proposed waterway. Make a profile of the existing natural channel including cross sections.

The waterway should then be divided into reaches having an approximately uniform slope and cross section. This will allow the waterway to be constructed in such a way that a minimum amount of earth will be moved. A significant break in slope makes a point of division between reaches.

The entrance point of tributary, where the watershed is significantly increased, is also a natural point of division between reaches. By using the drainage area for each reach and calculating the peak flow, the field engineer can design the waterway according to the reaches. During construction, the slope and shape of each reach is gradually adjusted to that of the next reach.

The cross-sectional shape of the waterway should be parabolic, a shape in nature generally found to be suitable for a stable channel and one in which small flows are least likely to meander. The shape allows easy crossing with farm equipment if the side slopes at the edge of the channel are gentler than 5 to 1. As shown in Fig 9.2 of the parabolic shape, T is the top width in feet and d is the maximum depth in feet occurring at the centerline. The shape is easy to visualize and build because at a width of $0.5T$ the depth is $0.75d$, and at a width of $0.7T$ the depth is $0.5d$ (see Fig 9.2).

9.8 Flow Velocity of Runoff Water

Because the erosion resistance of soil increases with dense vegetation, the maximum allowable flow velocity in feet per second (fps) is related to the thickness or density of the grass that covers the channel bed (see Fig 9.3).

In determining the width and depth of the channel required to carry the peak flow, it is necessary, as will be shown, to manipulate the velocity and flow area so that the channel will be large enough, stable, and crossable with farm implements.

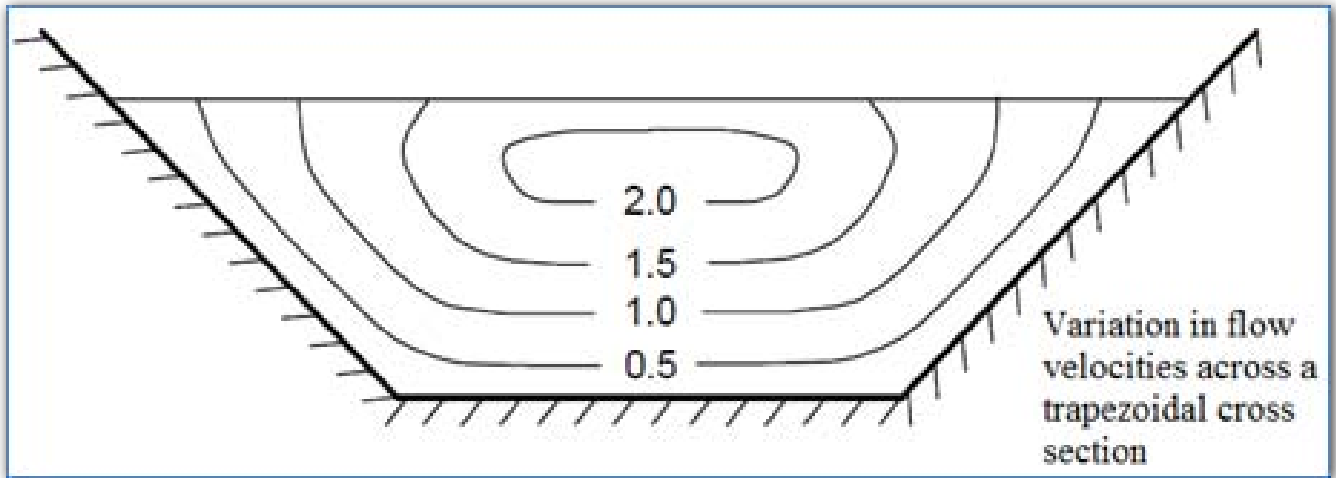

Fig 9.3: Variation in flow velocity across a trapezoidal waterway

$$V = \frac{R^{2/3} S^{0.5}}{n}; R = \frac{A}{P}$$

Where:

V = Mean flow velocity (m/s);

R = hydraulic radius (m);

S = channel gradient/slope (m/m);

n Manning's coefficient of roughness;

P = the wetted perimeter, that is the length of the line of contact between the water and the channel boundary (m).

The mean flow velocity in a channel can be calculated using the Manning's Formula. The formula is applicable for steady uniform flow, which for design purpose assumes that flow is constant and uniform. Flow in channels can be described as critical, subcritical or supercritical.

Although it is assumed that the mean velocity is constant for each cross-section, there is a variation in actual velocities at each cross section. Frictional losses occur where the runoff comes in contact with the wall and the base of the channel.

The greater the degree of roughness in the channel, the greater the amount of friction, which results in reduced velocities (Fig 9.5 shows an example of such variation in velocity).

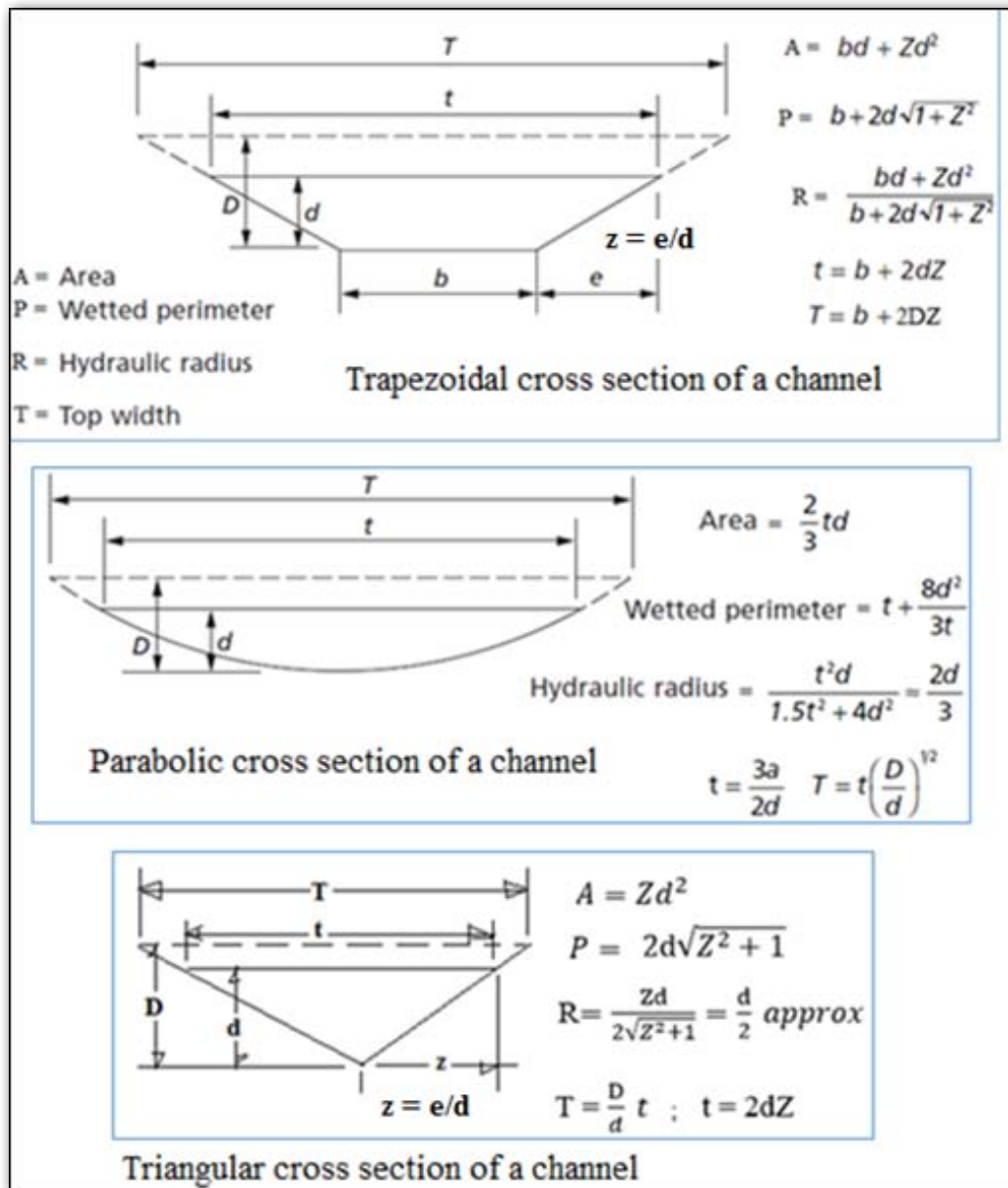

Fig 9.4: Formulae for dimensions relating to Trapezoidal, Triangular and Parabolic cross-sections

Note: Freeboard = $D - d$ for all sections.

9.9 Capacity of a Waterway

Given below are the hydraulic equations that may be used in designing a grassed waterway. The principal one is the Manning equation for open channel flow: The hydraulic capacity of a channel can be determined by multiplying its cross-sectional area by the mean velocity as in the following formula:

$$Q = AV = \frac{A * R^{2/3} * S^{1/2}}{n}$$

Where:

Q = the discharge or hydraulic capacity of the channel of waterway, m³/s

V = average flow velocity in meter per second (m/s)

A = Cross sectional area of channel (m²)

n = roughness coefficient

R = hydraulic radius in meter

S = slope of channel bed in meter per meter

Different grasses vary in their resistance to the flow of water. The stems and leaves of the grass bend and oscillate under the influence of the velocity and the depth of flow. This flow can be predicted by the Manning Equation, which is given and explained later in this publication. The hydraulic capacity of a channel can be determined by multiplying its cross-sectional area by the mean velocity as in the following formula:

Flow resistance is expressed in the Manning Equation as the roughness coefficient or 'n' value. Research published by different Soil Conservation Services relates the n value in the Manning Equation to the product of VR (that is, the velocity multiplied by the hydraulic radius). These factors are related by a family of curves having different values of retardance. The Manning Formula for flow of water is expressed as follows:

$$V = \frac{R^{2/3} * S^{0.5}}{n}$$

Where:

V = mean velocity of flow (m/s)

n = Manning coefficient of roughness

S = channel slope (m/m)

R = hydraulic radius (m)

The hydraulic radius (R) is dependent on the cross-sectional area of flow and the wetted perimeter and is expressed by the following formula:

$$R = \frac{A}{P}$$

Where:

A = the cross sectional area of flow (m²)

P = the wetted perimeter, that is, the length of the line of contact between the water and the channel boundary (m).

9.10 Subsurface Drainage

A drainage way that is normally wet should be tilled before a good grassed waterway can be established. The design of the waterway should therefore include the tile drainage (see Fig 9.5). The tile line should be at least 60 cm lower than the center of the constructed waterway and at least one-third the width of the waterway as measured from the center-line of the waterway (see Fig 9.5). Tiling provides adequate drainage and also reduces erosion of the back fill materials in the tile drain. The size of the tile must be such that the tilling not only drains the waterway channel effectively, but also fits into the entire local tile

drainage system. Such a tile line, located adjacent to a waterway, often acts as a tile main, serving other upstream tile lines.

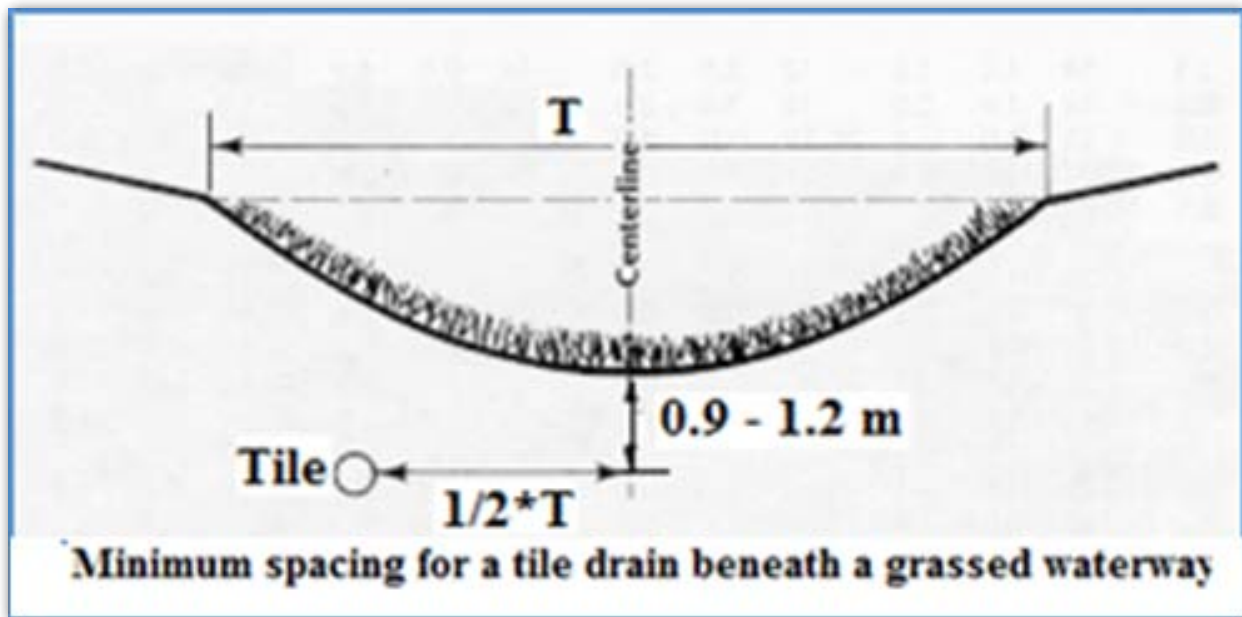

Fig 9.5: Spacing for tiled drain beneath a grass waterway

9.11 Manning Roughness Coefficient

The Manning's coefficient (n) is dependent on the roughness characteristics of the channel boundary surface. The characteristics relevant to the design of soil conservation structures include:

- ♣ The surface roughness or texture of the channel boundaries;
- ♣ The presence and composition of vegetation – this effect can be complex and variable e.g. grasses will offer significant resistance at low discharge but less resistance under high flows (see n - VR relationships above);
- ♣ Discharge (or flow) depth – the value of n is likely to be high at shallow depths when much of the boundary to the flow consists of the coarse material of the channel bed;
- ♣ The presence of bends, irregularities and obstructions.

9.12 The n - VR Relationship in Channels Lined with Vegetation

Waterways used in soil conservation layouts usually depend on a well-established vegetal cover for long-term stability. The nature of this cover can change significantly depending on the seasonal conditions and management practices. The Manning's ' n ' factor in such waterways is greatly affected by the composition and depth of the vegetation, when the flow completely or nearly submerges the vegetation.

Table 9.1: Values of Manning's n Coefficient of Roughness

Channel/stream condition	Manning's Coefficient, n
Earth channels subject to intermittent flow and with vegetal lining	The n/VR relationship applies Refer to text in this chapter
Contour bank channels: <ul style="list-style-type: none"> ▪ Smooth and bare ▪ Roughly cultivated ▪ Sparse grass cover ▪ Wheat crop or standing wheat stubble ▪ Sorghum (25 cm rows) 	0.02-0.03 0.04 0.05 0.07-0.15 0.04-0.12
Lined Channels excavated in rock: <ul style="list-style-type: none"> • Smooth and uniform rock • Jagged and irregular rock • Concrete-smooth forms or troweled 	0.025-0.040 0.035-0.050 0.012
Small natural streams: <ul style="list-style-type: none"> • Straight, uniform and clean • Clean, winding, with some pools and shoals • Sluggish weedy reaches with deep pools • Very weedy reaches with deep pools 	0.025-0.033 0.033-0.045 0.050-0.080 0.075-0.150

Source: Pilgrim, Queensland Main Roads Department, Ree (1987, 1979, 1954)

Under the influence of velocity and depth of flow, vegetation tends to bend and oscillate continuously. Such conditions have an effect on the retarding of flows and the retardance varies as the velocity and depth of flow changes.

The n-VR relationship refers to the fact that n varies with the product of velocity and hydraulic radius (VR). The design of vegetation-lined channels requires that n be compatible with the value of VR.

9.13 Hydraulic Radius

For a given cross-sectional area, the shorter the wetted perimeter the greater will be the hydraulic radius and the greater the resulting velocity in the channel. The channel cross-section with the maximum hydraulic radius would be a semi-circle (parabolic).

For a trapezoidal channel, the maximum hydraulic radius (and highest velocities) would result in a channel that most closely approximates a semi-circle.

For triangular cross-sections, the hydraulic radius is approximately equal to half the depth. For waterways of width greater than 20 meters it is safe to assume that the depth of flow is equal to the hydraulic radius. For example, a trapezoidal waterway with 1:3 (V to H) side batters and a bottom width of 20 meters will have a hydraulic radius of 0.29m when carrying a depth of flow of 0.3 meters.

It is recommended to use a parabolic or trapezoidal cross section channel/waterways. The V-shaped or triangular shape waterways are not recommended since they readily form gullies and are more erosive. The cross-sectional area should be large enough, relative to the design flow, soil type and vegetation to maintain runoff velocities below erosive levels.

9.14 General Design Approach

When carrying out a design for a soil conservation structure or waterways, it is useful to consider and use the following combined equation:

$$\frac{Q}{A} = V = \frac{R^{2/3} * S^{1/2}}{n}$$

Where:

- Q = the discharge or hydraulic capacity of the channel (m³/s)
- A = cross sectional area (m²)
- V = average velocity (m/s)
- R = hydraulic radius (m)
- S = channel slope (m/m)
- n = Manning coefficient of roughness.

In a design exercise the following factors in the above equation would normally be known:

- * Discharge Q.
- * Velocity V – it is normal to design for a selected velocity.
- * The channel slope S would be known in the case of a waterway design; however in the design of a contour or diversion bank, it is a variable and different channel slopes (gradients) can be compared.
- * The Manning Coefficient of roughness n would be selected as a fixed value or as a retardance value where n/VR relationships apply.

The design may however have other constraints. Examples are as follows:

- ◆ Conditions in the channel are subject to considerable variation depending on seasonal and management conditions.
- ◆ The top width for a waterway may be a limiting factor because a waterway needs to fit into a confined location.
- ◆ The length of a contour bank batter may be set by the planting machinery used by a farmer.

By incorporating the known values of Q, V, S and n into the above equation it is possible to determine values for the cross-sectional area A, and the hydraulic radius R. This is a straightforward exercise if the value of Manning's n is constant but in the case where n varies with the product of V and R an iterative process is required to solve the equation. The value of n will also vary with seasonal and management conditions e.g. a waterway can have abundant growth in a good season or be virtually bare during a drought. A contour bank channel may vary from a ploughed condition to an advanced crop or stubble depending on the cropping cycle.

The exercise then becomes a geometrical one in which it is necessary to determine which dimensions of the selected cross-section will give the required values for R and A. Charts can be used for this purpose. Alternatively another iterative process is required to obtain the correct dimensions.

9.15 Waterway Construction Methods

Remove all brush and rocks larger than 15 cm in diameter and bury them elsewhere, not beneath the waterway. Drive centerline stakes to mark the intended waterway (see Fig 9.5). Using offset stakes will help maintain planned grades and aid in checking construction. If the subsoil in the area will not support the growth of grass, remove the topsoil from the waterway and stockpile it nearby, out of the way.

Shape the waterway to the design grade and parabolic cross section and fill the gullies gradually. Spread the stockpiled topsoil evenly over the surface of the shaped waterway. Frequently measure the width, depth, and grade of the waterway to be sure it complies with the design. The conditions below are important to be fulfilled:

1. Centerline elevations must be as planned so that a uniform grade is maintained.
2. Depth at a distance of one-fourth of the top width from the center should change from d to $0.75d$ (see Fig 9.2).
3. Edges should be feathered into the adjacent topography outside the design cross section.

The final shaping of the waterway surface is critical. The surface must be smooth because small mounds or holes will create local flow velocities that will destroy the waterway by erosion. All changes in grade from one reach to the next should be smooth and gentle. If a waterway is improperly constructed or has a non-uniform grade or an incorrect cross-sectional shape, it is likely to be unstable and to erode rapidly.

9.16 Planning and Design of Grassed Waterway

Probably the single most important condition in establishing a grassed waterway is that the grass be planted immediately after earthmoving is completed. If the grass is not established quickly, the bare earth of the channel will be eroded. This erosion will change the shape of the waterway, destroying its efficiency and often requiring that the waterway be rebuilt.

1. On smaller drainage areas, field observations may produce accurate estimates. A simple estimation method on larger areas is to determine the distance from the highest point in the drainage area to the outlet of the waterway (hydraulic distance).
2. The minimum capacity shall safely convey the peak runoff expected from a 10 year frequency - 24 hour duration storm. If the waterway is used as an outlet for a companion conservation structure or within an urban/residential area the capacity will be increased to accommodate a higher design frequency (25 year - 24 hour duration storm).
3. Generally, the grassed waterway cross-section shall be parabolic to reduce meandering risk. Trapezoidal grassed waterway cross-sections are recommended for steeper slopes and for larger runoff discharge.
4. The minimum grassed waterway depth shall be 30 cm. The depth shall be increased as required to properly outlet diversion terraces or other structures that are designed to outlet into the waterway and to assure better row drainage. The recommended side slopes shall be 6:1 to 8:1 to improve waterway crossing and farming activities.

5. The maximum grassed waterway width shall be less than 20 m except where other suitable outlet locations or methods cannot be found. The minimum width shall be greater than 6 meters where crossing with farm equipment is required.
6. Where the design peak discharge of the grassed waterway is greater than 2.8 m³/s and/or the design velocity is greater than the permissible velocity, the waterway shall be designed with a stone center, non-degradable erosion control matting or in combination with other special conservation structures as required to safely discharge peak flow.
7. Subsurface drainage shall be installed as required to eliminate continuous or base flow in the waterway and provide proper conditions for vegetative growth. Drains shall be located on each side of the waterway and not installed within the center two-third width of the waterway.
8. Maximum permissible velocities shall be selected in accordance to specified and recommended values.

9.17 Construction and Maintenance of Waterways

A grassed waterway cannot be kept in good repair without regular attention. This is especially true if it carries a large volume of water or is located on a steep slope. Sodding or reseeding small breaks in the sod, fastening down any loosened sod, and sloping back and sodding small overalls are some ways to avoid having to make extensive repairs later. Never use a waterway as a road. The ruts or breaks that will be made in the sod will endanger the waterway, and controlling burrowing rodents such as groundhogs and moles is also important. In general, construction and maintenance activities of waterways should consider the following important activities:

1. Establish a maintenance program to maintain waterway capacity, vegetative cover, and outlet stability. Vegetation damaged by machinery, herbicides, or erosion must be repaired promptly.
2. Inspect grassed waterways regularly, especially following heavy rains. Fill, compact, and reseed damaged areas immediately. Remove sediment deposits to maintain capacity of grassed waterway.
3. The waterway shall be excavated or shaped to the lines and grades as required to meet this standard and be free of bank projections or other irregularities which will impede normal flow.
4. All trees, brushes, stumps, obstructions and other objectionable materials shall be removed from the side and disposed of in a manner consistent with environmental concerns and proper functioning of the waterway.
5. Protect waterway from concentrated flow by using diversion of runoff or mechanical means of stabilization such as silt fences, mulching, hay bale barriers to stabilize grade during vegetation establishment.
6. Minimize damage to vegetation by excluding livestock whenever possible, especially during wet periods. Permit grazing in the waterway only when a controlled grazing system is being implemented.
7. Avoid use of herbicides that would be harmful to the vegetation in and adjacent to the waterway area.
8. Avoid using waterways as turn-rows during tillage and cultivation operations.
9. Mow or periodically graze vegetation to maintain capacity and reduce sediment deposition. Mowing may be appropriate to enhance wildlife values, but must be conducted to avoid peak nesting seasons and reduced winter cover.
10. Apply supplemental nutrients as needed to maintain the desired species composition and stand density of the waterway.
11. Control noxious weeds.
12. Topsoil shall be removed from excavation areas and replaced during final grading as required to promote good vegetative growth.

13. Fill shall be compacted or field rocks used as required to prevent excessive/unequal settlement that would result in damage to the completed waterway.
14. Excessive subsoil removed during waterway construction shall be used for land forming, access road construction and/or stockpiled in an unused area outside of the waterway.
15. Grassed waterways designed and constructed as part of a system that diverts runoff water from its natural outlet shall require the written permission of affected downstream or adjacent landowners, or the road construction authority if road ditches are used.
16. All construction operations shall be performed as required to reduce soil erosion, and shall be built in a period where seeding can take place and adequate vegetative cover can be established. If constructed just before the rain period, waterways must be protected with appropriate erosion control matting to limit damage from runoff events until vegetative cover can be established.
17. Erosion control mats will be used in place of temporary ditches to encourage the proper establishment of vegetative cover in the waterway. The width of the mat installed shall be equal to the width of the waterway required to safely discharge a 5 year - 24 hour storm.
18. The owner of the grassed waterway shall be advised of other complementary soil conservation practices and of grassed waterway maintenance procedures.

Chapter 10

Flood Damage and Its prevention

10.1 Description

Techniques for preventing flood damage can be classified as structural and non-structural approaches. Structural flood control measures reduce flood hazards by controlling the flow of water in rivers and streams whereas non-structural techniques for preventing flood damage are based on acceptance of flooding as a natural process that cannot be completely controlled. Because flooding is only a problem when floodwaters interfere with human activities, non-structural approaches focus on altering human behavior. Non-structural techniques include floodplain management, stream corridor protection, flood proofing of existing structures, removing flood-prone development, storm water management, watershed management, flood warning, and flood response. Effective management of flood risks requires a balance of both structural and non-structural flood damage prevention measures.

One of the best ways to prevent flood damage is to keep flood-prone areas free from development, human and livestock interferences. Undeveloped buffers along rivers, streams, and lakes allow for fluctuations in these dynamic hydrologic systems with minimal damage to human activities. In addition to reducing the potential for flood damages, preserving floodplain lands as open space greatly enhances the naturally beneficial functions that floodplains provide. Floodplain management involves regulation of new development within areas that have been mapped as high flood hazard zones.

10.2 Adverse Effects of Storm Water

Storm water is water from the rain that doesn't soak into the ground but runs off into waterways. It flows from bare soil surfaces, rooftops, over paved areas, and through sloped lawns while picking up a variety of materials on its way. As it flows, storm water runoff collects and transports soil, animal waste, salt, pesticides, fertilizers, oil and grease, debris and other potential pollutants. The quality of runoff is affected by a variety of factors and depends on the season, local meteorology, geography and upon activities which lie in the path of the flow. Storm water gathers a variety of pollutants that are mobilized during runoff events and degrades lakes, rivers, wetland and other waterways runoff. Now flood risk management is based on an analysis of flood hazard, exposure to flood hazard, and vulnerability of people and property to danger. Agricultural extension and rural development institutions have to explain to land users how improved practices can enhance and sustain their incomes while conserving soil fertility and soil moisture and reducing runoff and erosion hazards.

Storm water management mitigates the adverse impacts of development by implementing practices to control the amount and timing of runoff from development sites. Because any activity that affects drainage characteristics or erosion in a watershed can impact flooding problems, watershed management is a critical component of flood risk management efforts. Inappropriate land use management has been a shortcoming of flood management due to the unprecedented pace of socioeconomic development and the increase in population densities. To apply land use planning as a flood management is required especially at local levels where most land use planning is practiced. Management of land use in upper watersheds has also been added as one of the aspects of flood management which include afforestation programs and programs to raise the awareness of land users the effects of inappropriate land use practices and to modify behaviour in agricultural communities.



Fig 10.1: Flood damage in Kasese town (source: DREF, 17 May 2013)

10.3 Stream Bank Erosion Hazards and its Protection

Flash flood mitigation in the upstream part of a catchment is aimed at reducing the occurrence of flash floods and focuses on reducing slope instability, reducing the amount and velocity of runoff, and preventing stream bank erosion. In the downstream areas, the focus is on mitigating the effects and impact of any flash flood that occurs. Several design issues are common to many of the structural stream bank stabilization methods.

In the selection and application of a particular stream bank erosion protection method, care must be taken to avoid merely transferring the erosion problem to another location. This requires the designer to not only understand the causes of stream bank erosion at the site in question, but also to take a comprehensive look at the entire stream reach, or even basin. In addition, the transition of structural erosion controls to and from natural stream banks is critical, but often overlooked and should be carefully analyzed and designed.

In many cases, two or more stream bank protection methods can be combined to create effective, environmentally sensitive stream bank stabilization plans. The morphology of a river is a strong determinant of flow, and can thus serve to intensify or mitigate flood waves and torrents. At the same time, when rivers flow in an alluvial plain they often become meandered, and at times of flood, this morphology leads to excessive bank cutting which can destroy agricultural land and other infrastructural development activities (see Fig 10.1 and Fig 10.2).

River training, which refers to the structural measures that are taken to improve a river and its banks, is an important component in the prevention and mitigation of flash floods and general flood control, as well as in other infrastructural development activities.

River training measures reduce sediment transportation and thus minimize bed and bank erosion (see Fig 10.4, Fig 10.6).



Fig 10.2: Flood damages and river bank erosion hazards

Many river training structures are implemented in combination with bioengineering techniques to lessen the negative effects on environment and landscape. There are a number of types of river training structures. The selection and design of appropriate structures depends largely on the site conditions. River training structures can be classified into two main categories: transversal protection structures, and longitudinal protection structures.

Transversal protection structures are installed perpendicular to the water course and they are used to lower the river gradient in order to reduce the water velocity and protect the river bed and banks from erosion. Intense rainfall and breakout events can accelerate the river flow to such an extent that the water has a significant impact on the watercourses and surrounding areas.

Transversal protection structures are effective for controlling the velocity of rivers and streams and reducing the development of flash floods. The major transversal structures useful in river bank protection include check dams, river dykes, bed sill, and sediment retention structures.



Fig 10.3: River bank collapse, caused by erosion, affects livelihoods of community

Check dams can be made of gabions, concrete, logs, bamboo, and many other materials. Check dams decrease the gradient of the torrent bed and reduce the water velocity during a flood event by increasing the time of concentration of the hydrographic basins and reducing the flood peak and solid transportation capacity of the river. They also help to reduce erosion and debris flow. The main purpose of check dams on rivers is to stabilize the riverbed over a long distance. Check dams generally require additional protection structures in the bed or on the banks to hinder undermining (see Fig 10.4, Fig 10.6).

A dyke is a structure made to project flow from a river bank into a stream or river with the aim of deflecting the flow away from the side of the river on which the dyke is built. Two to five structures are typically placed in series along straight or convex bank lines where the flow lines are roughly parallel to the bank. Dykes help train or direct a river to flow along a desired course by preventing erosion of the bank and encouraging flow along a channel with a more desirable width and alignment. Spur dykes are used to control natural meandering at a river bend, to channel wide rivers, and to convert poorly defined streams into well-defined channels.

The spur dykes create a zone of slack flow which encourages silting up in the region of the dyke to create a natural bank. They generally protect the riparian environment and often improve the pool habitat and physical diversity. Spur dykes can be made from many materials including stone, for example in the form of gabions or in bamboo 'cages'; tree trunks and branches; concrete; or any material that is not easily detached by the river and is strong enough to withstand the flow and the impacts of debris. They can be categorized on the basis of permeability, submergence, orientation, and the shape of the head.

On the other hand, a bed sill or ground sill is a transverse gradient control structure built across the bed of a river or stream to reduce bed or headward erosion. Sills are installed along river stretches with a medium to low morphological gradient. The purpose is similar to that of a check dam, but a sill is much lower.

A sill is usually constructed together with other hydraulic structures such as bridges to prevent them from being undermined and increase their durability.

Sills can be built with different shapes, for example stepped or sloping, and from a variety of materials including concrete, stone, gabions, wood, and rock. The selection of material depends on morphological and ecological factors. Sills made from wood, rock, and gabions tend to be more environmentally friendly than those made from concrete or cemented stones.

Longitudinal protection structures are installed on river banks parallel to the river course, generally with the aim of protecting adjoining areas from inundation, erosion, and river meandering. They are usually constructed on natural banks and extend for a considerable distance. The most common structures are embankments or levees in the form of guide bunds or banks, afflux bunds, and approach embankments. Very often, spur dykes are constructed together with longitudinal structures to protect the latter. Some common longitudinal river bank protection structures include earth fill embankment, guide banks, concrete embankment, revetments and rock rip-raps, channel lining, and bamboo piles.

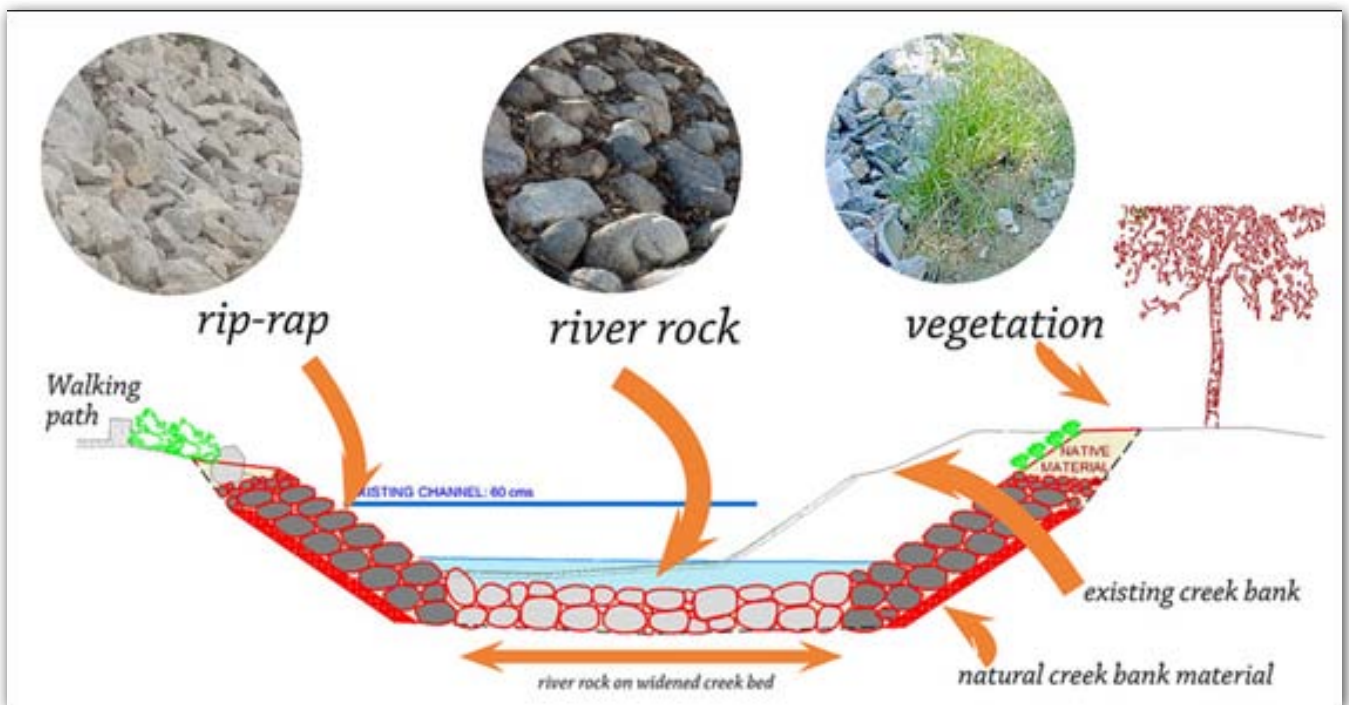

Fig 10.4: Different river bank erosion mitigation & protection strategies

Depending on the slope, types of soil of the river bank, amount of discharge, and velocity of flow, an appropriate method of improvement has to be employed. In cases of river banks with mild slope and shallow depth of water in the river, methods such as stone gabions, concrete block revetment, and sand filled sacks are recommended. Sack revetments are widely used for emergency flood protection.



Fig 10.5: River bank erosion control is effective with retaining walls

In rivers with bulkheads where groundwater is also part of the erosion stone revetment will be appropriate. In cases where the depth of water is more with bulkhead gabion wall structures are preferred solutions. When the depth of water in the river is more than 7.0m reinforced concrete counterfort wall will be more appropriate solution to prevent bank erosion.

10.4 Stream Bank Protection with Gabion Check Dams

Gabions are rectangular wire baskets, filled with four to nine inch rock and bound together to form a structure. Gabions are stacked on steep slopes and provide higher resistance for the velocity range of 2-5 m/s in which small riparian stones are unstable. The advantages of gabions are that they conform to minimal shifts in the soil, and are adaptable to a wide variety of applications. Generally speaking, the appearance of gabion structures is considered less intrusive than similarly configured concrete structures.

The disadvantage of gabions is that maintenance is necessary to preserve the integrity of the structure. Trees and branches carried by turbulent floodwaters can damage the wire baskets by either lodging themselves in the basket, or by pulling the wire and deforming the boxed configuration.

If gabions are to be used in a structural application, this damage could lead to the loss of a large portion of the gabion structure during a single storm event. Special design considerations are needed for structures which are frequently inundated by turbulent floodwaters and subjected to bombardment of damaging debris. When gabion walls are being used as erosion control measures, an engineer or expert experienced in flood control and erosion prevention, should be consulted. Gabions are proven method of halting river bank erosion, for both large rivers and small streams that are prone to flooding.

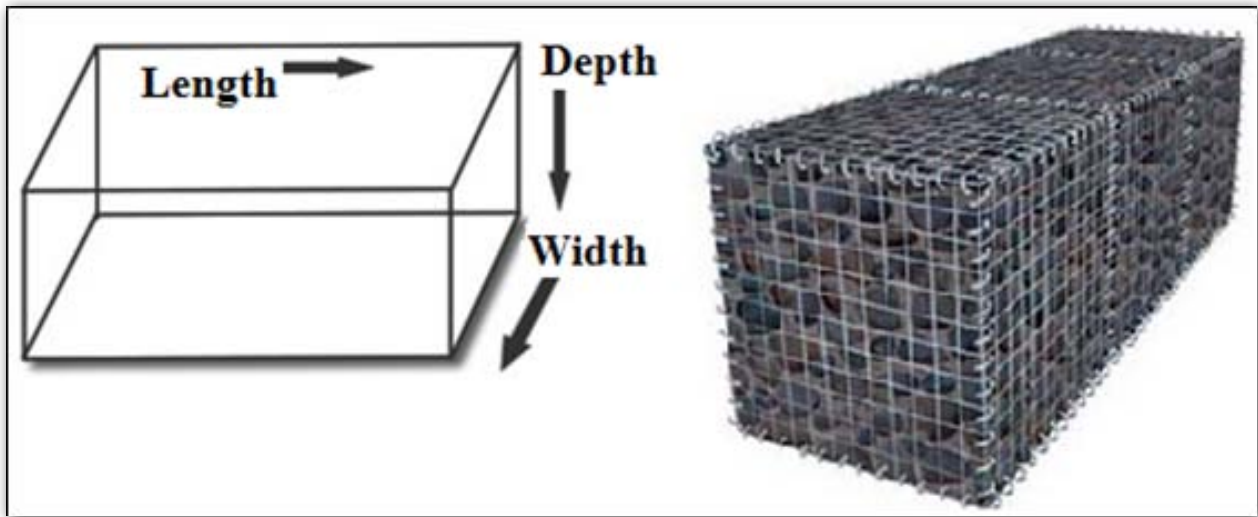

Fig 10.6: Design of stone filled rectangular gabion check dam

Any river erosion system needs to be designed to cope with the expected peak river flood volumes, as this is when most damage to river banks and their erosion protection measures occur.

Flood events are often described as 1 in 100 years' flood events or 1 in 50 years' floods, and any river bank protection system needs to be able to cope with these flood events.

The design of all river bank protection measures needs to consider the soil profile, soil type, (clay, gravel or sand), expected peak river flow, and expected maximum river channel scour depth. Though different methods of flood control measures are needed depending on the site conditions, gabion walls are heavy, and are able to resist the river during flooding. Larger gabions can be used around bridge abutments, and are able to use cheaper stones thereby reducing the river bank protection costs.

Gabions are rectangular wire baskets filled with stones, and are very versatile and may be used as revetments (see Fig 10.3). There are different types of gabions such as mattresses and upper level baskets. Mattress type gabions are baskets which are usually 9 to 12 inches thick and provide a foundation for the upper level baskets. Upper level baskets should be about 6, 9, and 12 feet in lengths and 1, 1.5, and 3 feet in heights.

At the construction site, gabion baskets are unfolded and assembled by lacing the basket edges together with wire. Individual baskets are then laced together, stretched, and filled with stones. The lids are closed and then wired to other baskets. The result is a large heavy mass that is not as easily moved by waves or current as single stones might be.

Gabion baskets, made of heavy galvanized steel with PVC coating steel wire in a hexagonal mesh for corrosive environments, are in general suitable on sites where bulkheads or revetments are acceptable. The stones used to fill the baskets are usually in the range of 4 to 8 inches.

Gabions are suggested for use in brackish and freshwater environments, where corrosion of the wire will be minimal. The baskets should be staggered and joined, much like the courses of a brick wall, in order to form a stronger structure. It is also recommended that the end of the mattresses be anchored with large stones or anchor screws.



Fig 10.7 Gabion basket placed at river bend to prevent river bank erosion during flooding

Damage to the baskets should be repaired immediately, and missing stones from the basket should also be replaced from time to time to maintain a tightly packed basket. This will minimize stone movement which can cause abrasion damage to the basket wires. The main advantage is that the construction of gabions may be accomplished without heavy equipment. The structure is flexible and continues to function properly even if the foundation settles. Adding stones to the baskets is an easy maintenance procedure. The cost of using gabions may be low compared to other protection methods depending on the distance of the stones from the construction site.

Stone mattresses made of heavy galvanized (or polyethylene) meshes, typically one meter wide with a thickness of 20 cm to 25 cm is laid on top of a stone toe. The backfilled slope should be first covered with a filter layer/geotextile separator. The mattress is filled with relatively small size stones covered with mesh and wired together. However, this method of protection will suffer from scouring of damped stones toe at high flow velocities which leads to foundation failure.

Chapter 11

Design and Construction of Community Pond

11.1 Description

A farm pond is a body of water created either by constructing a dam across watercourse or by digging a pit. Ponds are either embankment ponds, which are built across a watercourse, or excavated ponds which are excavated or dug. Ponds are used to store surface water for use during dry seasons for the purpose of: (1) domestic or livestock use; (2) human consumption; (3) small or medium scale irrigation; and (4) fish production and recreation.

Shape of farm ponds can be circular or rectangular. Hand dug ponds are usually made circular and ponds constructed by machine are usually rectangular. The size of a pond depends upon or determined by the amount of water required to be stored and size of the catchment area contributing runoff to the pond. The amount of water required to be stored depends upon the number of humans and different livestock, for which water will be used, and also the number of days of use in a year.

11.2 Selection of Pond Site

Suitable site for a pond is where a limited amount of excavation will be required to contain, or hold back, a large volume of water. A valley where a dam can be constructed at a narrow pass is a good example. The field designer should also think about the size of the catchment area to get enough runoff to fill the pond. Some of the general water sources of a pond to be considered are: (1) overland drainage - surface runoff from precipitation or a spring flowing overland. Adequate supply of runoff water into the pond will be determined by the drainage area, annual precipitation rates and other hydrological factors;

(2) impounding flowing waters - this can be a plentiful water source for a pond. Impounding flowing water can have adverse reactions, such as sediment from upstream to fill in the pond and this will require occasional removal of the sediments; and (3) other sources - if water cannot be obtained from the preceding natural sources, other options are available. For example, diversion or collection ditches can be constructed to catch water from overland drainage that may bypass the pond.

Some important points to be considered in the selection of ponds sites are: (a) pond should be located at a point where maximum volume of water can be collected with least digging or earth fill; (b) ponds for livestock should be well spaced as the livestock should not travel more than one km; (c) to avoid pollution, the site should be away from farm drainage and sewage lines; and (d) pond drainage area should be sufficient to provide adequate surface runoff.



Fig 11.1 Improved design and construction of runoff water harvesting pond (Kotido)

11.3 Layout of a Rectangular Hand-Dug Pond

Some of the procedures to be followed in constructing hand-dug labour intensive ponds are:

(1) mark the pond on the ground; (2) start digging the pond; and (3) keep the soil 3 meters away from the edge of the pond. This will prevent the slide back of the excavated or embanked soils into the pond.

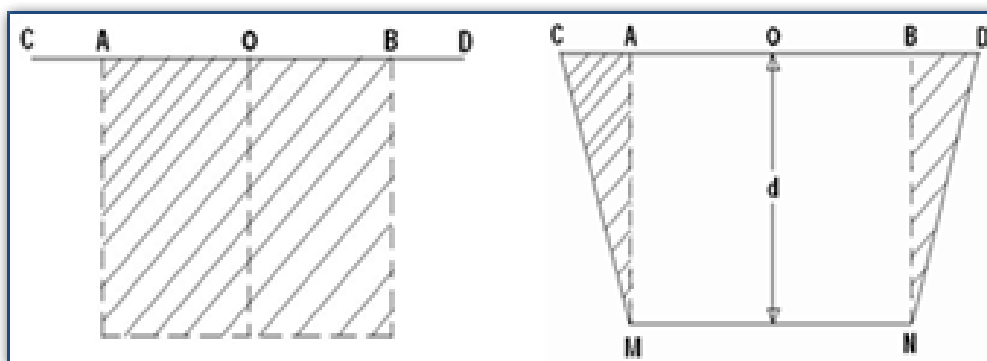

Fig 11.2 Layout & cross-section of a pond

As indicated in Fig11.2, to construct a rectangular pond, the steps are: (1) consider point O as the center of the pond; (2) if the side slopes are considered to be the same in both sides, the distances of points AC

and BD are equal, and similarly, distances of points OA and OB are as well equal; (3) start excavating or digging AMNB first and then shape CAM and DBN, as shown; and (4) excavate similar dimensions on widthwise direction.

11.4 Pond Maintenance

If the soils around the pond are not of the type that will adequately hold water, it is recommended to line the pond with a layer of at least 30 cm of soil with a high clay content. This is called lining or plastering of a pond. This includes physical removal by hand with a rake or hoe, which allows selection of specific plants to be removed. The plant roots are usually removed which provide a somewhat permanent effect. Planting a good grass cover should protect exposed surfaces of the dam, spillways and any other disturbed areas. For bigger size ponds, protection from wave action on the upstream face can be achieved by stone ripraps to absorb the majority of the force of the waves.

Riprap is a loose assembly of rocks used to line the shore of the pond and protect it from wave action or erosive forces of moving water. The rocks should be large enough not to be moved under the force of the waves. The stone riprap should extend from the top of the dam to at least 0.6 –1.0 m below the lowest expected level of the pond. If a stream is involved, consider digging a small catch pool (sediment trap) upstream to trap sediment or introduce streamside plantings to act as buffers reducing the amount of sediments entering the pond. This type of control requires involvement by surrounding landowners that may have no concern for the pond.

11.5 Seepage Losses

Ponds lose water either through evaporation or seepage. Losses due to evaporation depend on air temperature, wind speed, air humidity and length of the dry season or day. Seepage losses from ponds with a clay seal soil are less than 0.03 cm per hour or about 2.50 m in a year. Generally speaking, the losses due to seepage from ponds, located at different altitudes are related as follows:

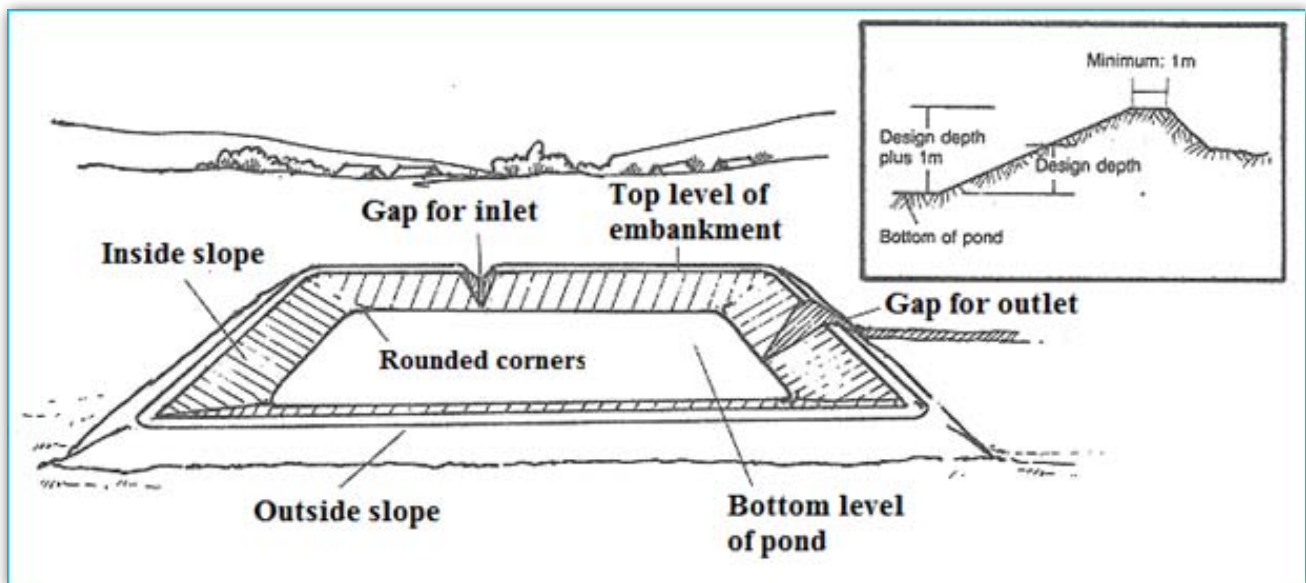

Fig 11.3 Sectional view of a rectangular pond with inlet and inner side embankment

1. To avoid the deep percolation and seepage losses from the pond, soil test pits are important. Test pits are holes dug in the earth at various points in the proposed pond location or water storage area. It is very important that a number of test pits are dug, and that someone who is familiar with geological parameters inspects them.
2. Soil test pits are excavated below the planned depth of a pond and are used to determine the feasibility of the site for a pond. This will allow to detect any potential problematic areas such as bedrock, or rock cracks or fissures.

11.6 Reducing Seepage and Evaporation Losses from a Pond

To reduce seepage and evaporation losses, the soil at the bottom of the pond should be well compacted and sealed with clay blankets. For sandy soils, the bottom of the pond should be covered with a layer of clay blankets. As shallow ponds lose more water due to evaporation from the wide surface area, increasing the depth of the pond and reducing its surface area can reduce evaporation losses. A deeper pond is, therefore, better than a wider pond because it loses less water through evaporation. Hand dug ponds should be generally of 20 to 40 m in diameter and 3 to 6 m in depth, with the side slope of 1: 1 (1 vertical to 1 horizontal).

Altitude above sea level, m.	Losses due to Seepage and evaporation
500 --- 1000	3.70 --- 4.80
1000 --- 1500	3.20 --- 3.70
1500 --- 2000	2.90 --- 3.20
2000 --- 2500	2.50 --- 2.90
Above 2500	Less than 2.50

Table 11.1 Seepage loss at different altitude

11.7 Calculating Capacity of a Farm Pond

To avoid the need to build expensive bypass structures to evacuate the excess water, the size of the pond should be proportional to the size of drainage or catchment area. The daily use of water in water-scarce areas is shown as follows. To know the minimum depth of a pond, losses due to seepage and evaporation must be considered while designing it. Minimum depth of ponds under different conditions of climate and rainfall are indicated in the table (Table 11.2).

According to the elevation of the pond location, to determine the volume of water to be stored in the pond, the volume of expected water use should be calculated.

Consumers or beneficiaries	Consumption, liter / day
Human being	15 -- 25
Cattle	20 --- 40
Milk cow	70 -- 100
Camel	40 -- 90
Donkey	10 --- 15
Horse	30 --- 40
Sheep	3 --- 5
Goat	3 --- 5
poultry	0.20 – 0.30

Table 11.3 Daily water requirement for different domestic use

Climate	Rainfall, mm	Min. depth of water over 25% of pond area, m
Humid	1000 - 1500	3
Semi-arid	750 - 1000	3.5
Sub-humid	500 - 750	4

Table 11.2 Minimum depth of ponds under different conditions

Volume of a pond is calculated based on the shape of the pond. Hence, volume of a circular labour intensive pond can be calculated by multiplying the average area of the pond by its depth. To avoid collapsing or sliding of the sides of ponds, it should have a certain permissible side slope. The volume of the sloping sides therefore should be deducted from the total volume of the pond.

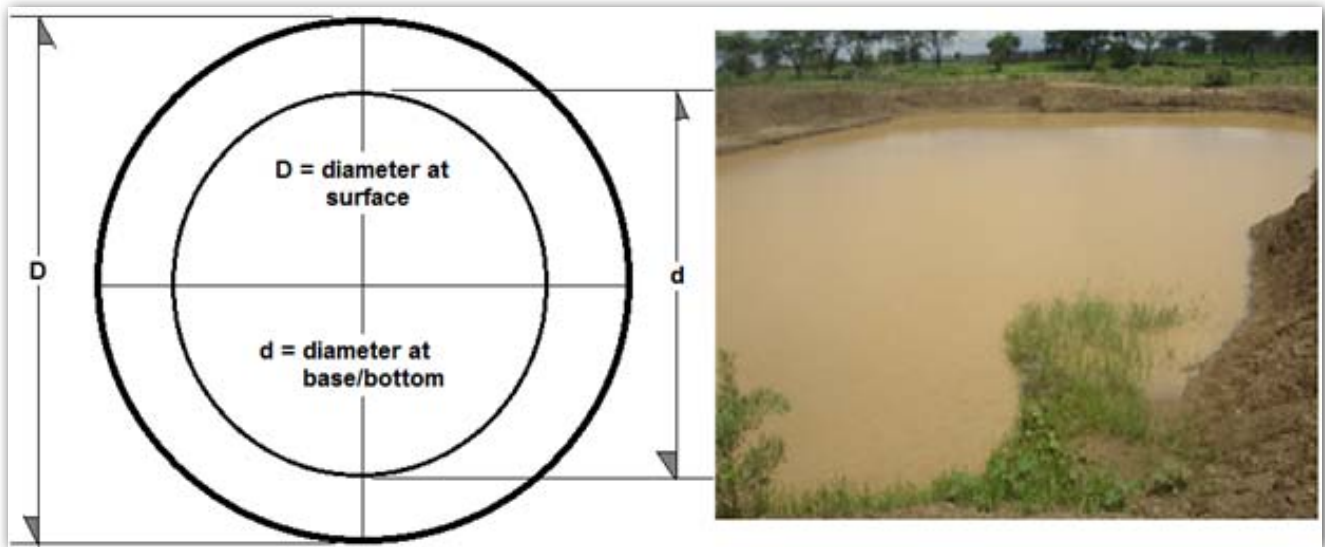

Fig 11.4 Sectional top view and actual view of a hand dug circular pond

The average area of a circular pond is calculated using the following formula:

$$A_s = \frac{\pi D^2}{4}$$

$$A_b = \frac{\pi d^2}{4}$$

$$\pi = 22 / 7 = 3.1428.$$

Where:

A_s = Area of pond at the surface, m^2

A_b = Area of pond at the base or bottom, m^2

Average area (A_{av}) of the pond can then be calculated by taking the average of the surface and base areas.

$$A_{av} = \frac{A_s + A_b}{2} = V = \frac{\frac{\pi D^2}{4} + \frac{\pi d^2}{4}}{2} = \frac{\pi (D^2 + d^2)}{8}$$

Where:

A_{av} = Average area of the pond in m^2

Table 11.3 Daily water requirement for different domestic use

The average volume or capacity of a pond can be calculated by multiplying the average area of the pond by its depth.

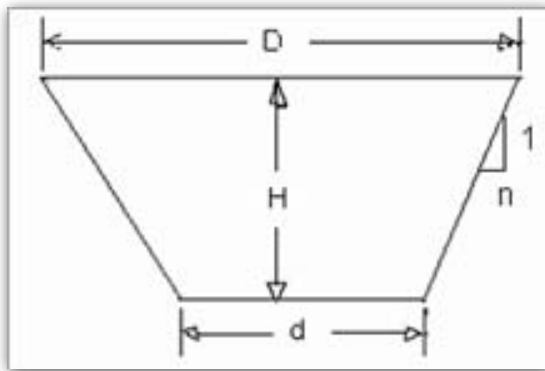

Fig 11.5 Sectional view of a circular pond

$$V_{av} = A_{av} \times H = \{3.1428 (D^2 + d^2)/8\} \times H$$

Where:

V_{av} = Volume or capacity of the pond in m^3

H = Depth of the pond in m.

D = Diameter of the pond at the surface in m.

d = Diameter of the pond at the bed of the pond in m.

Similarly, volume of a rectangular pond can be calculated by multiplying the average area of the pond by its depth.

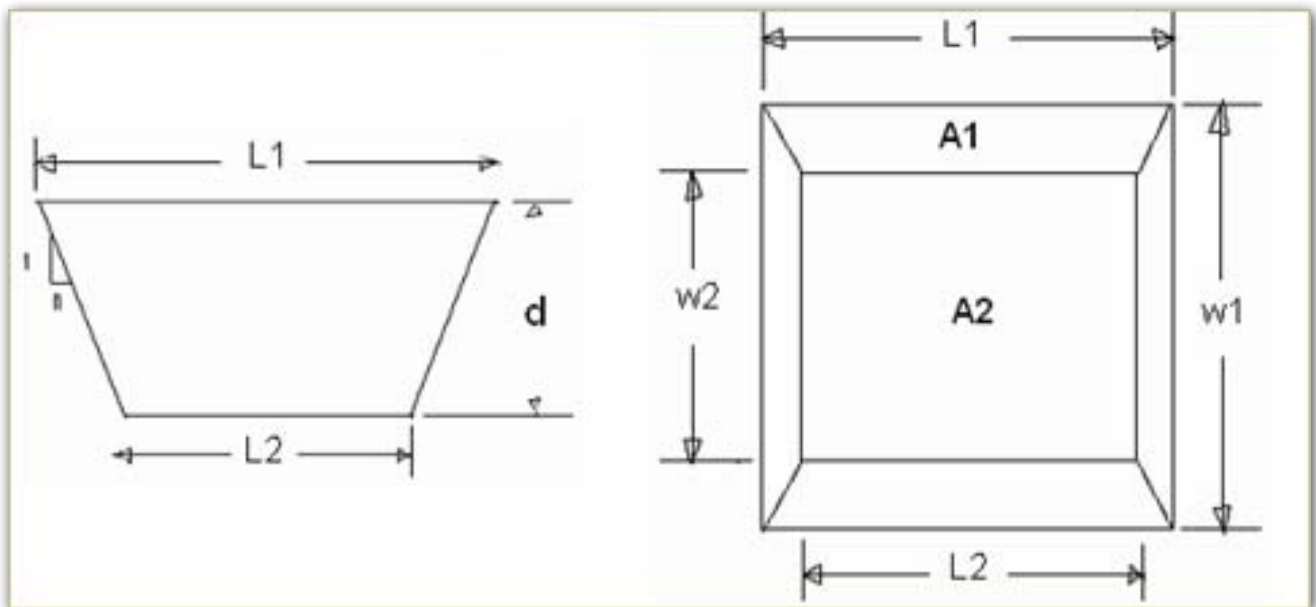

Fig 11.6 Sectional and top view of a rectangular pond

The surface area (A_1) and area at the bottom of the pond (A_2) is calculated as follows:

$$A_1 = W_1 \times L_1$$

$$A_2 = W_2 \times L_2$$

$$A_{av} = (A_1 + A_2)/2 = \{(W_1 \times L_1) + (W_2 \times L_2)\}/2$$

Where:

A_{av} = is the average area of rectangular pond in m^2

A_1 = Area at the surface of the pond in m^2

A_2 = Area at the base of the pond in m^2

W_1 = Width of the pond at the surface, m

W_2 = Width of the pond at the base, m

L_1 = Length of the pond at the surface, m

L_2 = Length of the pond at the base, m

Likewise, volume of a rectangular pond can be calculated by using the following formula,

$$V_{av} = A_{av} \times d = \left[\frac{(W_1 \times L_1) + (W_2 \times L_2)}{2} \right] \times d.$$

Where:

V_{av} = average volume or capacity of the rectangular pond in m^3

d = Depth of the pond in m

The volume of excavation required for the pond can also be estimated with enough accuracy by using the prismoidal formula:

$$V = \frac{(A + 4B + C)}{6} \times D$$

Where:

V = Volume of excavation, m^3

A = Area of the excavation at the ground surface, m^2

B = Area of the excavation at the mid-depth ($1/2 D$) point, m^2

C = Area of the excavation at the bottom of the pond, m^2

D = Average depth of the pond, m

Some of the procedures to be followed in construction labour intensive hand dug ponds are:

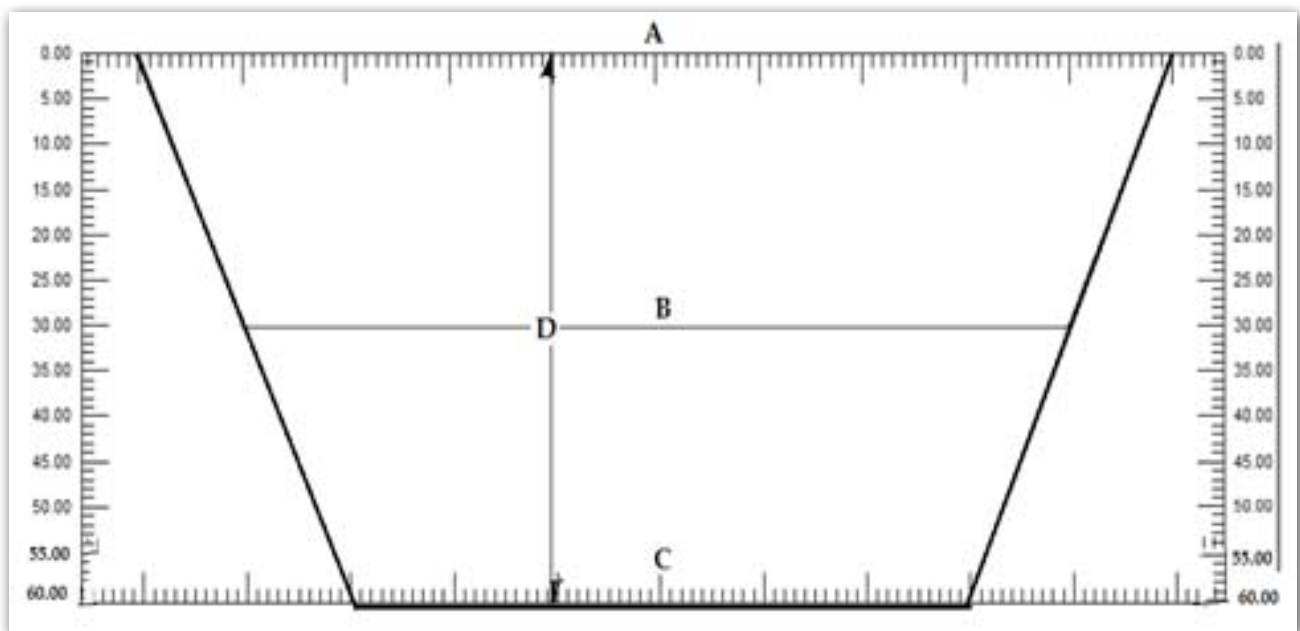

Fig 11.7 Calibrated calculation of volume of a pond using Prismoidal Formula

- ♣ Mark the pond on the ground;
- ♣ Start digging the soil;
- ♣ Keep the soil 3 meters away from the edge of the pond;
- ♣ Leave an opening in the circular mound around the pond for filling and taking water from the pond; and
- ♣ Place stone steps along the side of the pond, or construct side steps (see Fig 11.8) for the facility of taking out water by the people. The side steps are constructed to take out water from the pond at any depth of the pond without any difficulties.

Livestock should not be allowed to enter the pond. Instead water should be carried out to a trough for their uses. If livestock are allowed to enter the pond, the sidewalls of the pond will be broken and the pond will be filled with soil and the water will be polluted. The best way to exclude the livestock away is to fence the pond.

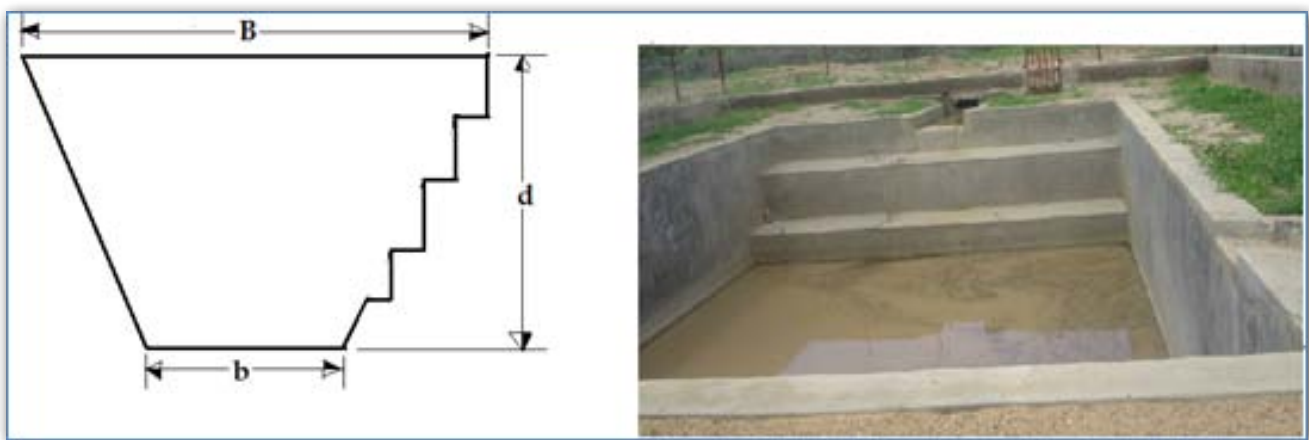
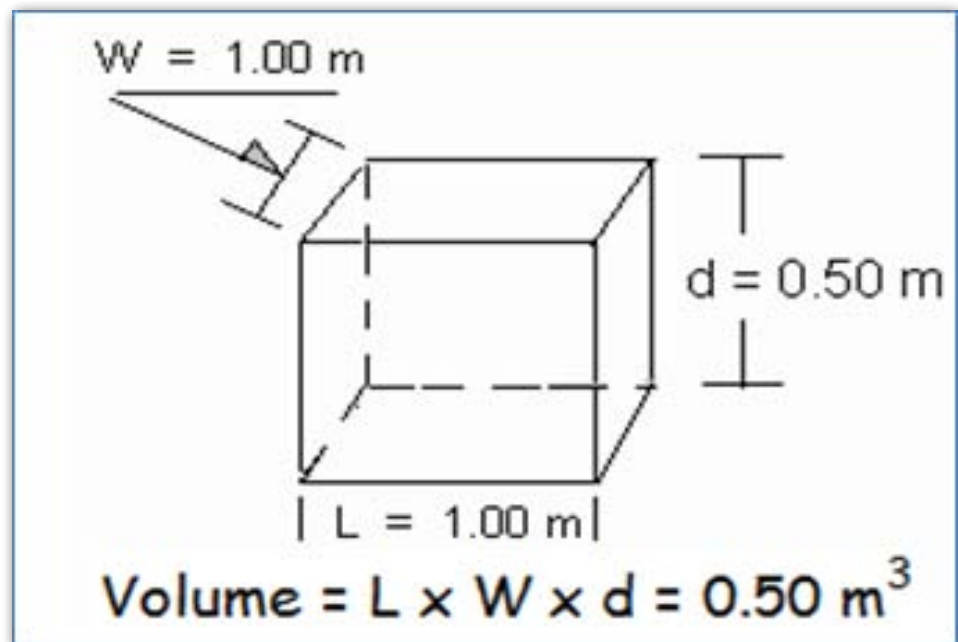

Fig 11.8 Construction of steps/stairs to manually draw water from a water pond

Work norm for pond construction: The labor requirements of the hand-dug ponds depend on the type of earthwork. The rate of digging the soil for a pond depends on the texture of the soil. Sandy soils are easier to dig than the clay soils. Average work-norm for a pond is $0.50 \text{ m}^3/\text{person-day}$.



Chapter 12

Design and Construction of Earth Embankment Dam

12.1 Description

Earth fill dams are the most common type of dams built to any height. They are designed as a non-overflow section with separate spillway. The reason for such wide-spread use of earthfill dams are: (a) the foundation requirements are not as rigorous as other dams; (b) local available soil is the main construction material; (c) high skill is not required; (d) no special plants are required; and (e) most earth-moving machines or labour intensive human labor can be used.

Depending on the fill material used, the two principal types of embankment dams are earth fill dam and rock-fill dam. An earthfill dam of any size must be designed to be safe and stable during its entire life including construction. For an earthfill dam the following design considerations indicate many of the requirements which must be met if safety is to be assured.



Fig 12.1 Typical view of zoned earth embankment dam

- ♣ The slope must be stable and resistant to deformation under all operating conditions, including rapid reservoir drawdown.
- ♣ Seepage through embankment and its abutment and foundation must be controlled so that piping and sloughing do not occur.
- ♣ The embankment must be safe from overtopping by both flood inflow and wave action.
- ♣ The embankment must be safe from catastrophic failure during reasonably expectable damages at the site.
- ♣ The slope must be safe from excessive damage from wave action or rain.

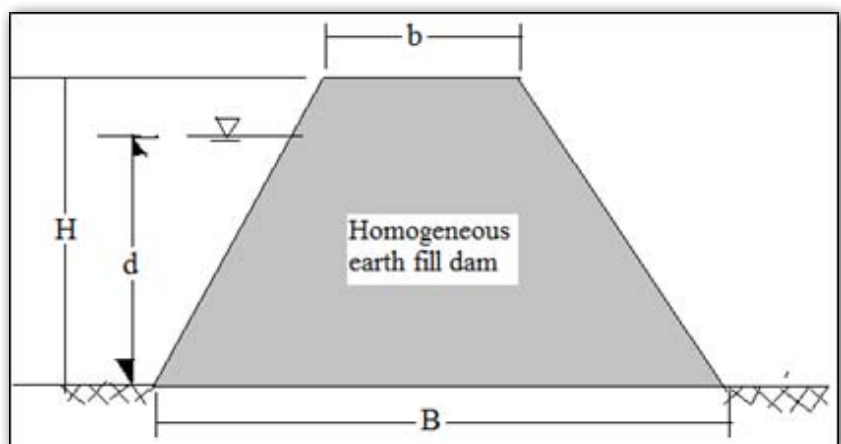

Fig 12.2 Sectional views of homogeneous earth embankment dam

An earthen or earth fill dam may be homogeneous or zoned type. A homogeneous earth dam is purely composed of a single kind of material. If only one type of suitable material is readily available nearby, a homogeneous section is generally preferred.

If the material available is impervious or semi pervious, a small quantity of pervious material is required as casing for protection against cracking. On the other hand if it is pervious, a thin impervious membrane is required to form a water barrier.

The purely homogeneous type of section has now been replaced by a modified homogeneous section, in which a small amount of carefully placed pervious material controls the action of seepage so as to permit much steeper slopes as compared to pure homogenous dam. Zoned earth dam is composed of a central impervious core flanked by zones of materials considerably more pervious called shells.

Zoned section earth dam is the most popular type used nowadays in which the cross section is divided into zones. The outer zones are more pervious to have a free draining property while the inner zone or the core zone is made up of an almost impervious clayey soil to check or control the seepage. The core of the earth dam provides impermeable barrier within the body of the dam. Impervious soils are generally suitable for the core. However soils having high compressibility and liquid limit, and having organic contents may be avoided, as they are prone to swelling and formation of cracks. The following guidelines are recommended for design of a core zoned earth fill dam: (1) the core may be located either centrally or inclined upstream; (2) the minimum top width should be kept 3 meters; (3) the top level of the core should be fixed at 0.5 m above the maximum water level; and (4) the side slopes may be kept 1:2 and 1:1.

Fig 12.2 Sectional views of homogeneous earth embankment dam

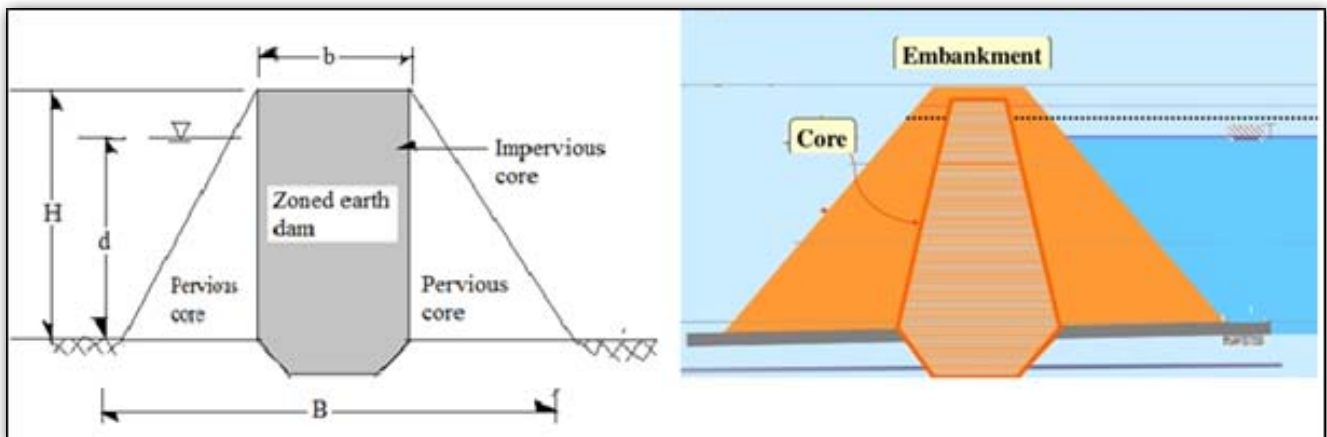

Fig 12.3 Cross sectional views of zoned earth embankment dam

The main components of the earth dam are cut off; core; casing; internal drainage system and foundations; slope protection; surface drainage; and impervious blanket. Thickness of core at any section shall not be less than 30% (preferably not less than 50 percent) of maximum head of water acting at that section. The upstream and downstream earth dams should be protected against waves or soil erosion. The upstream slope protection of earth dams is ensured by providing stone riprap. A minimum of 30 cm thick stone riprap over 15 cm thick filter layer may be provided up to the top of the dam. The downstream slope protection is also ensured by sodding or riprap. It is usual practice to protect the downstream slope from rain-cuts by providing suitable sodding (please note that grass sodding on the upstream side of the earth fill dam is not recommended as it is drowned or inundated by the stored water) or riprap on the entire downstream slope from top to toe drain.

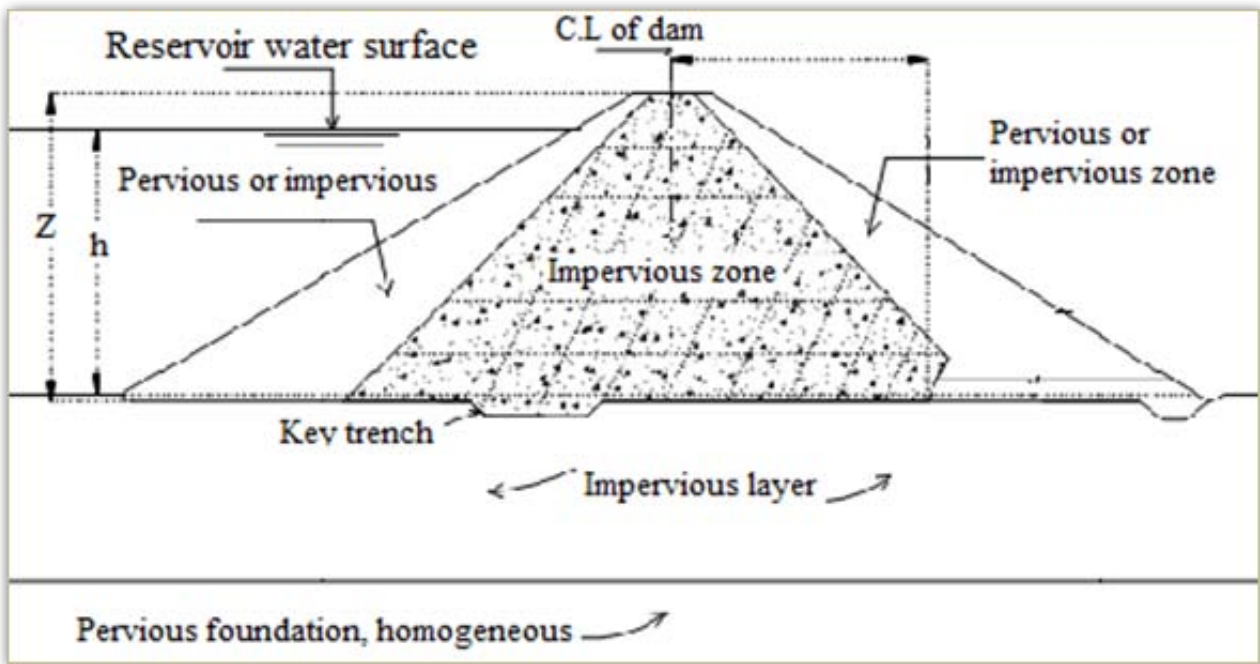

Fig 12.4 Typical cross section of a zoned earth fill dam

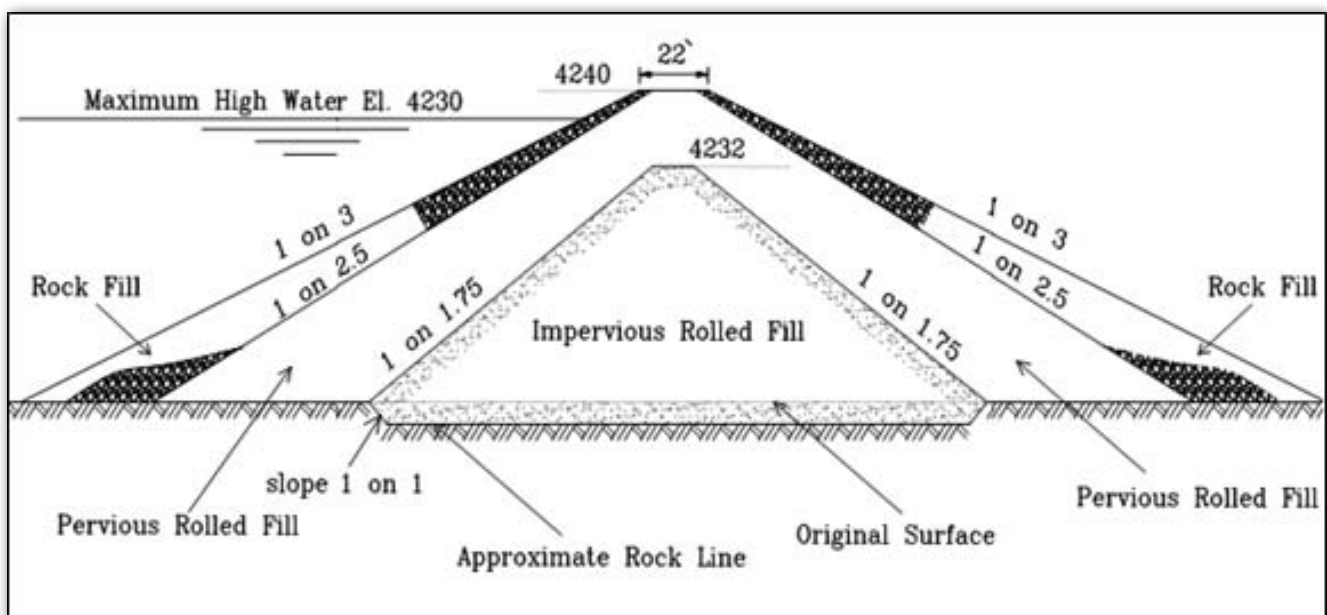

Fig 12.5 Typical zoned cross section of a zoned earth fill dam

To ensure safety of an earth dam, it is very important to handle the seepage water in the dam so as to maintain the original particles of soils in their place. The measures commonly adopted for safe disposal of seepage water through embankment dams are: (a) inclined or vertical filter (chimney filter); (b) horizontal filter; (c) rock toe, and (d) toe drain.

12.2 Components of Earth Dam

Small earth embankment dams are normally constructed of native materials from the immediate vicinity of the dam. For dams on pervious foundations, seepage control is necessary to prevent excessive uplift

pressures and piping through the foundation. The methods for control of under seepage in dam foundations are horizontal drains, cutoffs, upstream impervious blankets, downstream seepage berms, toe drains, and relief wells. An earth dam is composed of suitable soils obtained from borrow areas or required excavation and compacted in layers by mechanical means. Following the preparation of a foundation, earth from burrow areas and from required excavations is transported to the site, dumped, and spread in layers of required depth.

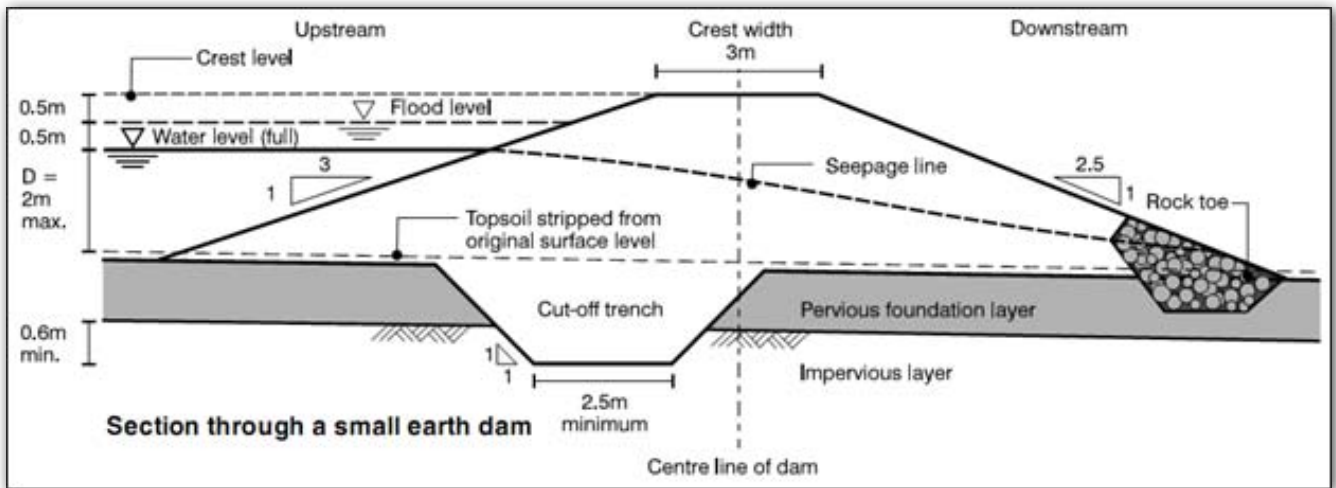

Fig 12.6 Typical cross sectional views and sections of an earth fill dam

The soil layers are then compacted by tamping rollers, sheep foot rollers, heavy pneumatic-tired rollers, vibratory rollers, or earth-hauling equipment.

The advantage of an earth dam is that it can be adapted to a weak foundation, provided that proper consideration is given to thorough foundation exploration, testing, and design. In all cases, it is desirable to determine the best methods of construction and compaction of earth fills on the basis of test quarry and test fill results.

12.3 Design of Small Earth Dams

Simple earth dams can be built where there is an impervious foundation, such as un-fissured rock, or a clay subsoil. The channel upstream should preferably have a gentle slope, to give a large reservoir for a given height of dam. An ideal dam site is where the valley narrows, to reduce the width of the dam and excessive earth work.

For the design of a uniform embankment dam of up to 3 m high, soil textures such as sandy clay loam, clay loam, silt clay loam, or soil with a higher clay content are suitable. Any of these soil types can be used provided that cracks do not form.

12.4 Construction of Small Earth Dams

A 3 meter high dam would typically have a 2 m maximum depth of water when full, increasing to 2.5m under flood conditions, with a 0.5m depth of flow over the spillway. The top 0.5m (minimum) is required to provide a safety margin (free board) which allows for water rising on the dam due to waves, and wear and tear on the dam crest.

The total design height of the dam must be increased for construction by at least 10 percent to take account of settlement. For small dams, well-compacted settlement should be between 5 to 10 percent of the height of the dam.

The construction materials should preferably be taken from the reservoir area. However, different parts of the side of the valley should be examined so that the most suitable soils are located (soil textures will vary according to position and depth in the valley). When constructing earth dams, the following materials should be avoided: organic material (including topsoil and decomposing material), material with high mica content, calcite clays, fine silts, cracking clays, sodic soils, schist and shale, and materials with roots or stones.

While constructing an earth fill, other points to be considered include:

- Construct the dam during dry season.
- Divert the stream by blocking it with a temporary low dam, or diverting it through a culvert (which could become part of the outlet works or spillway later).
- Strip topsoil because it contains organic matter (such as roots, debris, decomposed materials) which prevent proper compaction and create seepage routes (piping) once the organic matter has decayed:
- Pay attention to people's safety. Avoid hazardous practices and dangerous equipment.
- Place material in the dam: in layers of 10 to 20 cm deep and at the optimum moisture content when material can be rolled to pencil thickness without breaking, and is as wet as possible without clogging the roller.
- Compact with a heavy roller, or tramping animals or driving vehicles across (as required).
- Cover the whole downstream dam with topsoil to protect against erosion and plant strong grass such as kikuyu grass, star grass or Bermuda grass.
- Maintain the grass (water it in the dry season if necessary), but prevent trees with deep root, and keep out animals such as rats and termites
- Protect the upstream slope - lay a stone or brush mattress (for example bundles of saplings between 25 and 50mm long) on the slope, and tie it down with wire anchored to posts
- Secure a floating timber beam 2 m from the dam, which needs replacing every 10 years or so.

12.5 Seepage Control and Safety against Internal Erosion

Excessive seepage in a pond is usually due to a poor pond site or improper construction techniques. Some water will seep through the dam, even if it is constructed of good materials, and well-compacted and reduces the strength of the dam. However, sites where inadequate soils are encountered during construction should be sealed by "clay blankets" which consist of well graded material containing at least 20 percent clay. Thickness of the blanket depends on the depth of the water to be impounded. The minimum thickness of a clay blanket is 30cm for all depths of water up to 3m. It is recommended to increase this thickness by 5.0 cm for each 0.30 m of water over 3.0 m depth. It is recommended and advised to compact the clay material in layers of 15cm to 20 cm.

Existing ponds that have excessive leaks may also need clay blankets. Other materials to be used for sealing or plastering leaky ponds are bentonite, chemical additives, and waterproof linings. Bentonite is a fine textured colloidal clay. When saturated, it grows to many times its original volume. If mixed with well-graded, coarse grained material, thoroughly compacted, then saturated, the material tends to fill pores and blanket the leaking areas. Some chemical treatments can be added to fine-grained clay soils to

help in sealing seepage areas. This method can be quite complicated and a laboratory analysis of the soil is essential to determine which type of chemical additives will be most effective and at what rate it will be applied. Many types of materials are being used as waterproof linings. Geo-membrane and polyethylene are just a few. They could virtually eliminate seepage if properly installed. A cover of earth may also be needed for some linings to protect against punctures.

It is also a safer, but technically difficult solution to include a rock-toe drain to collect seepage water. This should extend up to a third of the height of the dam, and a graded sand and gravel filter must be placed between the dam fill material and the drain to prevent fine clay particles from being washed out. The filter must be designed according to the particle size of the dam material and the drain.

The seepage through the dam embankment and foundation should be to control piping, erosion, sloughing and excessive loss of water. Seepage control measures are required to control seepage through dam and foundation. If only one type of suitable material is readily available nearby, a homogeneous section is generally preferred. If the material available is impervious or semi pervious, a small quantity of pervious material is required as casing for protection against cracking.

On the other hand, if it is pervious, a thin impervious membrane is required to form a water barrier. The function of casing is to impart stability and protect the core. The relatively pervious materials, which are not subject to cracking on direct exposure to atmosphere, are suitable for casing.

12.6 Spillway Design

Spillways are structures constructed to provide safe release of flood waters from a dam to a downstream area, normally the river on which the dam has been constructed. A spillway is required to protect the dam from over-topping, for example during high flows. It passes surplus water downstream safely, preventing both the failure of the dam, and damage at the downstream. If the reservoir is full and flood waters enter the same, the reservoir level will go up and may eventually result in over-topping of the dam. To avoid this situation, the flood has to be passed to the downstream and this is done by providing a spillway which draws water from the top of the reservoir. A spillway can be part of the dam or separate from it. Spillways can be controlled or uncontrolled.

A controlled spillway is provided with gates which can be raised or lowered. In controlled spillway, when a reservoir is full, its water level will be the same as the crest level of the spillway. If flood enters the reservoir at this time, the water level will start going up and simultaneously water will start flowing out through the spillway.

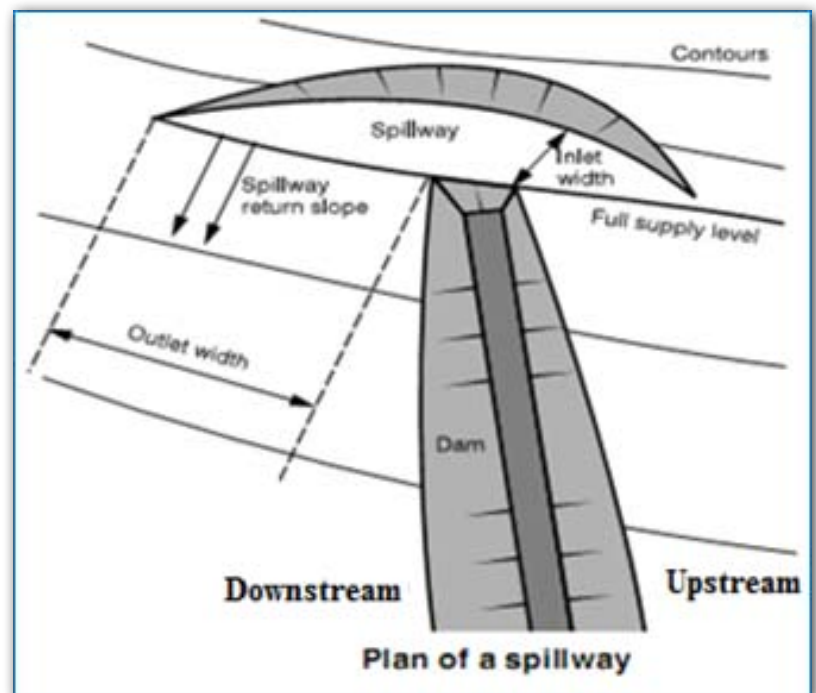

Fig 12.8 A typical top view or plan for a spillway

The rise in water level in the reservoir will continue for some time and so will the discharge over the spillway. After reaching a maximum level, the reservoir level will come down and eventually come back to the normal reservoir level.

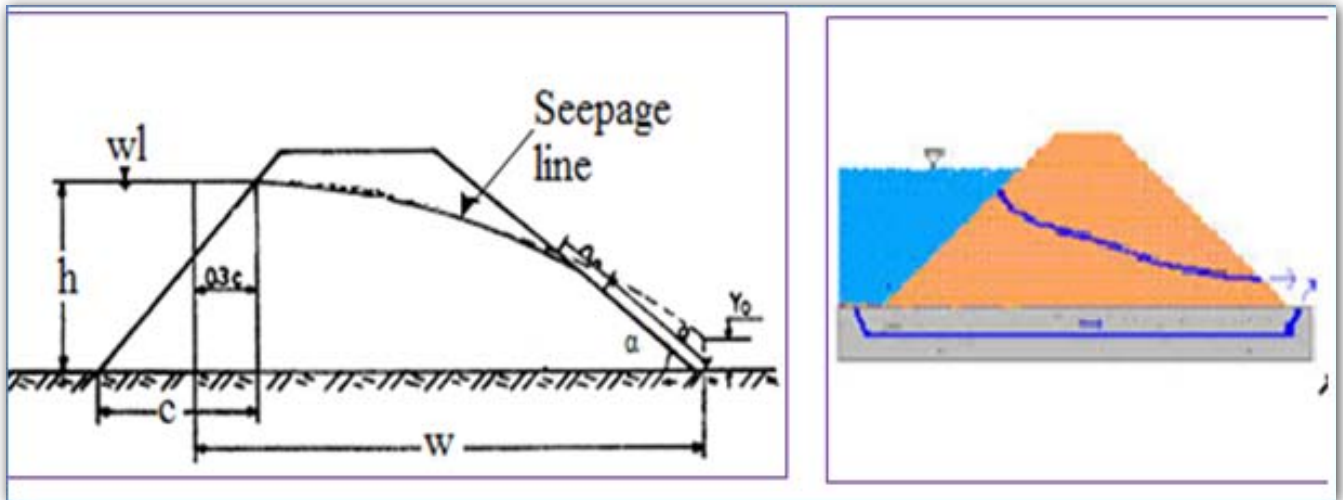

Fig 12.7 A typical seepage line for an earth fill dam

The top of the dam will have to be higher than the maximum reservoir level corresponding to the design flood for the spillway, while the effective storage available is only up to the normal reservoir level. The storage available between the maximum reservoir level and the normal reservoir level is called the surcharge storage and is only a temporary storage in uncontrolled spillways. In concrete and controlled spillway, water can be stored even above the spillway crest level by keeping the gates closed. The gates can be opened when flood has to be passed. Surplus water flows over a spillway crest at the top water level and into an open channel around the side of the dam, discharging safely into the stream below the dam. It may be made from reinforced concrete, but a cheaper solution is a grassed spillway with: (1) a vegetated earth channel; (2) protected crest at reservoir top-water level; and (3) at a maximum velocity of 2.5m/s.

A grassed spillway requires regular inspection and maintenance, so that erosion can be repaired and a good grass cover is maintained. It is often used together with a trickle-pipe spillway so that small inflows into a full reservoir flow through the trickle pipe do not erode the grass spillway.

12.7 Calculating Height and Storage Capacity of an Earth Fill Dam

The height of the dam will depend on the storage required in the reservoir. Therefore, to calculate the height and storage capacity of the dam: (1) determine the water requirement per day; (2) estimate the area of the reservoir; (3) estimate the evaporation and seepage losses per day and, hence, the volume of losses per day; (4) estimate the length of the critical period during which the stream flow is less than the water requirement and losses, ie when requirements would be met using the storage in the reservoir; and (5) estimate the average stream flow during the critical period and the effective storage required – ie (S) equal to water requirement per day plus evaporation and seepage losses per day minus average inflow per day multiplied by the length of critical period.

$$S = (R + Ax E - Q) \times T$$

Where:

R = daily water requirement in liter/day

A = is the reservoir area in m²

E = Estimated seepage and evaporation losses in mm/day

Q = Estimated average flow during critical period in liter/day

T = Estimated length of critical period in days

S = Total effective storage capacity or water required in liters.

Therefore, the dam must be high enough to store this quantity of water. The storage capacity of the reservoir (C liters) is best determined from cross-section surveys across the valley, but can be estimated from the area of the reservoir (A m²) and the maximum depth of water at the dam (D m) when full:

$$C = 330 A \times D = 330AD, \text{ liters}$$

The dam site should then be surveyed to estimate the area (A) of the reservoir for different values of D, and a trial-and-error method will then give the reservoir capacity (C) which meets the storage required (S) and provides a safety margin. The resulting value of A should then be used in the calculation of S to obtain a consistent result.

12.8 Reservoirs of a Dam

This is a natural or artificial place where water is collected and stored for use, especially water for the purpose of irrigation, drinking, land reclamation, electricity generation, fishing, recreation and/or protection of towns from flood damage or danger. It can be an artificial reservoir or permanent lake that is created at the upstream side of the dam. One major consideration in the development of any surface water resource project is the structural stability of the reservoir which should be capable of containing safely the projected volumes of water for use throughout its life time.

12.9 Factors Affecting Location for Reservoirs

One major consideration in the development of any surface water resource project is the structural stability of the reservoir, which should be capable of containing and storing safely the projected volumes of water for use throughout its life span. In this regard, the main factors to be considered for a safe reservoir are water-holding capability of reservoir area, bank storage, sedimentation, and seismicity. Failure to attain water-holding capability can be caused due to either the sliding or the erosion of a segment of the reservoir rim and seepage of water through the structure. Major slides into a reservoir would obviously reduce reservoir capacity and its service life considerably.

A dam may be over-topped due to the resulting wave action or rise of the water surface on account of a major slide into the reservoir. If the reservoir site is likely to be affected by the slides and cannot be abandoned, some restraining steps in reservoir operation should be taken to avoid serious failure. These steps could be in the form of limiting the filling and draw-down rates or imposing the maximum allowable water surface at a level lower than the maximum normal water surface. Alternatively, installation of drains to relieve water pressure along likely slip surfaces, some form of impervious lining, and pinning the unstable mass of its parent formation by rock bolting that can be resorted for preventing slides can be installed. Stabilization of the unstable mass can also be achieved by strengthening or replacing weak material. Grouting is the most common remedy for strengthening such weak masses.

It may be desirable to plan the steps to be taken to mitigate the effects of potential slide after it has occurred in spite of all preventive steps.

Reservoir water loss, either to the atmosphere or to the ground, can be a controlling factor in the selection of a site for a conservation reservoir. For a flood control reservoir, water loss is of concern only if it relates to the safety of the project. The lining of the surface through which seepage is expected is one of the preventive measures to reduce the reservoir water loss to the ground. At times, a blanket of impervious material extending from the heel of the dam is required, which also serves to control the seepage from the reservoir. Loss of reservoir water to the atmosphere occurs due to direct evaporation from the reservoir surface. The evaporation losses are affected by the climate of the area, shape and depth of the reservoir, wind conditions, humidity, and temperature. From considerations of evaporation, a reservoir site having a small surface area to volume ratio will be better than a saucer-shaped reservoir of equal capacity.

Streams usually bring water and sediment to reservoirs and deposit it in the reservoir due to the reduced stream velocity. Hence, the capacity of the reservoir is reduced on account of sediment deposition in the reservoir. A portion of the reservoir storage is usually reserved for the storage of the sediment. The life of a reservoir is predicted on the basis of the amount of sediment delivered to it, the reservoir size, and its ability to retain the sediment. Sediment deposition at the initial stage may be beneficial in the sense that it may have the effect of a natural blanket resulting in reduced seepage loss. Measures to minimize sediment deposition in reservoirs include catchment protection through a vegetative management program to prevent soil erosion, silt detention basins at inlets of smaller reservoirs, and low level outlets in dams to provide flushing action for removal of sediment from the reservoir. Of the various sediment control measures, catchment protection is the most effective but also expensive method.

12.10 Compaction of Soils for Embankment Dams

Leaks in earth-filled dams that lead to dam failures are often the result of inadequate compaction levels. The principal purpose and reason for compaction of soils is to reduce subsequent settlement under working loads. Compaction increases the shear strength of the soil and reduces the voids ratio making it more difficult for water to flow through soil. Compaction is important and required for an earth dam if the soil is being used to retain water. Compaction can prevent the buildup of large water pressures that cause soil to liquefy during wave pressure or other hazards.

The main factors affecting soil compaction include water content of the soil, type of soil being compacted and amount of compaction energy used. While compacting, water is added to soil (at low moisture content) and it becomes easier for the particles to move past one another during the application of the compaction forces. As the soil is compacted the voids are reduced and this causes the dry unit weight (or dry density) to increase. Initially, as the moisture content increases so does the dry unit weight. However, the increase cannot occur indefinitely because the soil state approaches the zero air voids line which gives the maximum dry unit weight for a given moisture content. Increased compaction effort enables greater dry unit weights to be achieved because of the shape of the no air voids-line must occur at lower optimum moisture contents. It should be noted that for moisture contents greater than the optimum use of heavier compaction machinery will have only a small effect on increasing dry unit weights. For this reason it is important to have good control over moisture content during compaction of soil layers in the field.

Compaction should be undertaken by using a tamper foot roller, commonly referred to as a sheep-foot roller. As a rule of thumb, to obtain the required compaction effort, the following should be undertaken as a minimum for all dams greater than approximately 3 metres in height and 3,000 cubic meter in capacity or volume:

- ♣ All fill material for the embankment should be placed in layers no greater than 15 cm thick.
- ♣ The largest size of the particle should not be greater than one-third of the height of the layer (that is not greater than 5 cm).
- ♣ Each layer should be thoroughly compacted before the next layer is placed. A minimum of six passes to achieve the required compaction effort is generally required by a suitable machine.
- ♣ The compaction effort achieved should be on average 98% standard maximum dry density, and the minimum compaction effort should be 95% standard maximum dry density. If the range of compaction effort varies throughout the dam, then it can lead to the dam embankment settling to different degrees causing the embankment of the dam to crack, which may ultimately lead to leakage and dam failure.
- ♣ The material forming the embankment should be placed with sufficient moisture to ensure proper compaction. The moisture content should be in the range of one percent to plus 3 percent of optimum moisture content. If the material is too dry, water should be added, and if the material is too wet it should be spread and mixed with dry soil to have permissible moisture content.
- ♣ Before each additional 15cm layer is added to the embankment, the preceding layer should be scarified to ensure that the two layers are properly joined so that no natural paths for seepage are present that may result in dam failure.
- ♣ If possible, a wheeled scraper or truck should be used for placing the clay on the dam site. The clay should then be spread by the use of the blade on a tamper foot roller or from a bulldozer towing a tamper foot roller.

Chapter 13

Design and Construction of Sand Storage Dam

13.1 Description

Sand storage dams (sometimes called ground water dams) store water under the ground. A sand storage dam is a small dam built above ground and into the river-bed of a seasonal sand river. Sand accumulates upstream of the dam, resulting in additional ground water storage capacity. Similar to sand storage or sand dam, a subsurface dam obstructs the ground water flow of an aquifer and stores water below ground level. Sand and subsurface dams are suitable for rural areas with semi-arid climate like Karamoja to store only seasonally available water to be used in dry periods for livestock, small scale irrigation as well as for domestic use. They can be built with locally available materials through LIPW but building the structure still requires relatively high investments., It is labour intensive and specific engineering expertise is needed.

Decentralized storage of water is an important strategy in semi-arid and arid regions outside the reach of perennial rivers, springs, deep groundwater or other adequate water sources like in many districts in Karamoja Region.

In many moisture stressed areas like in districts of Karamoja, storage of water from the rainy season to the dry season, or even from wet years to dry years is very important and top priority for livelihoods development and resilience building. In these districts, different water harvesting techniques and technologies, which are untapped resources can be achieved not only for domestic and livestock uses but also for small and medium scale irrigation development. If these runoff water during the rainy seasons can be harvested with properly designed water harvesting techniques and technologies, they can give a appropriate answers to the water needs of these communities.



Fig 13.1 A typical sediment storage dam (Kotido)

Sand storage dams can be built into the riverbeds of seasonal and intermittent rivers or wide gullies. These can capture and store water beneath the sand on the upstream of the sand dam and improve groundwater storage capacity of the riverbeds, subsurface and riverbanks storage which can generate small scale irrigation.

These types of reservoirs fill during the wet season, preventing quick runoff of valuable rainwater out of the catchment and out of reach of the community. If this can be done properly, which of course is not new in some areas in Karamoja, water availability during dry seasons can be prolonged and generally guaranteed for the community water needs.



Fig 13.2 Typical masonry sediment storage dam (Kotido)

However, the losses through evaporation in such arid and semi-arid areas are very high. The accumulated water, therefore, should be protected against contamination, seepage and excessive evaporation losses. Though water quality can be improved through natural filtration of sand or soil for the downstream use, it should also be protected against contamination.

13.2 Basic Design Principles

Before starting a sand dam project in these areas, the community must be intensively involved to create a feeling of ownership, which has proven to be the key factor in successful construction and maintenance of sand dams. In this case the full engagement of the community in decision-making, demand creation, mind set up and visioning should be of paramount importance. Different types of sand dams can be distinguished. Depending on the availability of the construction materials, these sand dams can be built of stone masonry, reinforced concrete, or simply loose rock or of earth embankment. However, the earth dam should consist of impermeable soil material (mostly clay or clayey soils, or black soils). Though an earth dam is not popular and is seldom used, it is relatively expensive to construct and it requires special skills for its design and construction. Otherwise, it can easily be damaged and even destroyed by underground flow.

13.3 Site Selection and Construction

The first step in sand dam is to carry out a site survey, which involves analyzing the geological and physical characteristics of the site, especially the underlying rock structures and soil properties. Riverbeds with crystalline rocks and coarse sand have higher yield compared with volcanic rocks. Similarly, river valleys and regions sloping between 1% and 2% are ideal sites for sand dams as they normally give the highest water storage. Knowledge of hydrological data is important for estimating the total stream flow, size of river transportation thereby influencing the thickness and height of the wall. Information on geological and topographical characteristics and even hydrological data can all be sourced from relevant government departments.

The second step is to obtain the required tools and materials. Essential materials include waterproof port land cement, nails, binding wire, timber, sand and stones, which are sometimes readily available along the riverbeds. Other equipment includes spade, sledgehammer, shovels, wheelbarrows, power mixer and water-containers. Where stones are readily available, masonry sand dams are recommended. Otherwise concrete walls are equally strong and durable.



Fig 13.3 A typical layout & construction of sediment storage dam (SS dam) in arid & semi-arid areas

To construct a sand dam a deep trench is first dug across the valley-wall or stream, reaching the bedrock or other stable layer like clay. To cut costs, local labour should be mobilized and involved in this process (community involvement through labour intensive public works).

A concrete or masonry wall is then built on the underlying rock bars across the river channels or intermittent stream so that it can trap and hold back the sand brought by the river during flooding or rain season. The height may range between 2 to 5m depending on the depth of the underlying rock or other stable layers. At either end of the dam especially where the valley sides are flat, wing walls may be added

at an angle to the main dam to direct and confine the flows of channel as the sand stores water in its pores. Since the natural sorting and deposition of sediments in streams is a function of channel slope and the shape of channel cross section, channel geometry is quite important in sighting the prospective sand dam. While channel slopes may vary in different valleys and regions, a slope of between 1% and 2% normally gives the highest water storage. The specific storage normally increases at the lower slopes than the higher ones.

After the construction of a sand dam, a new channel cross-section is created together with new gentler channel slope immediately upstream of the dam. The modified channel must safely pass the highest expected flood without overflowing the banks and threatening the bank abutments. In addition to rock outcrops for firm foundations, high riverbanks are another desirable feature. Where banks are low the dam has to be raised on either or both sides and wing walls extended beyond the banks in order to direct floodwater and prevent it from cutting around the dam.

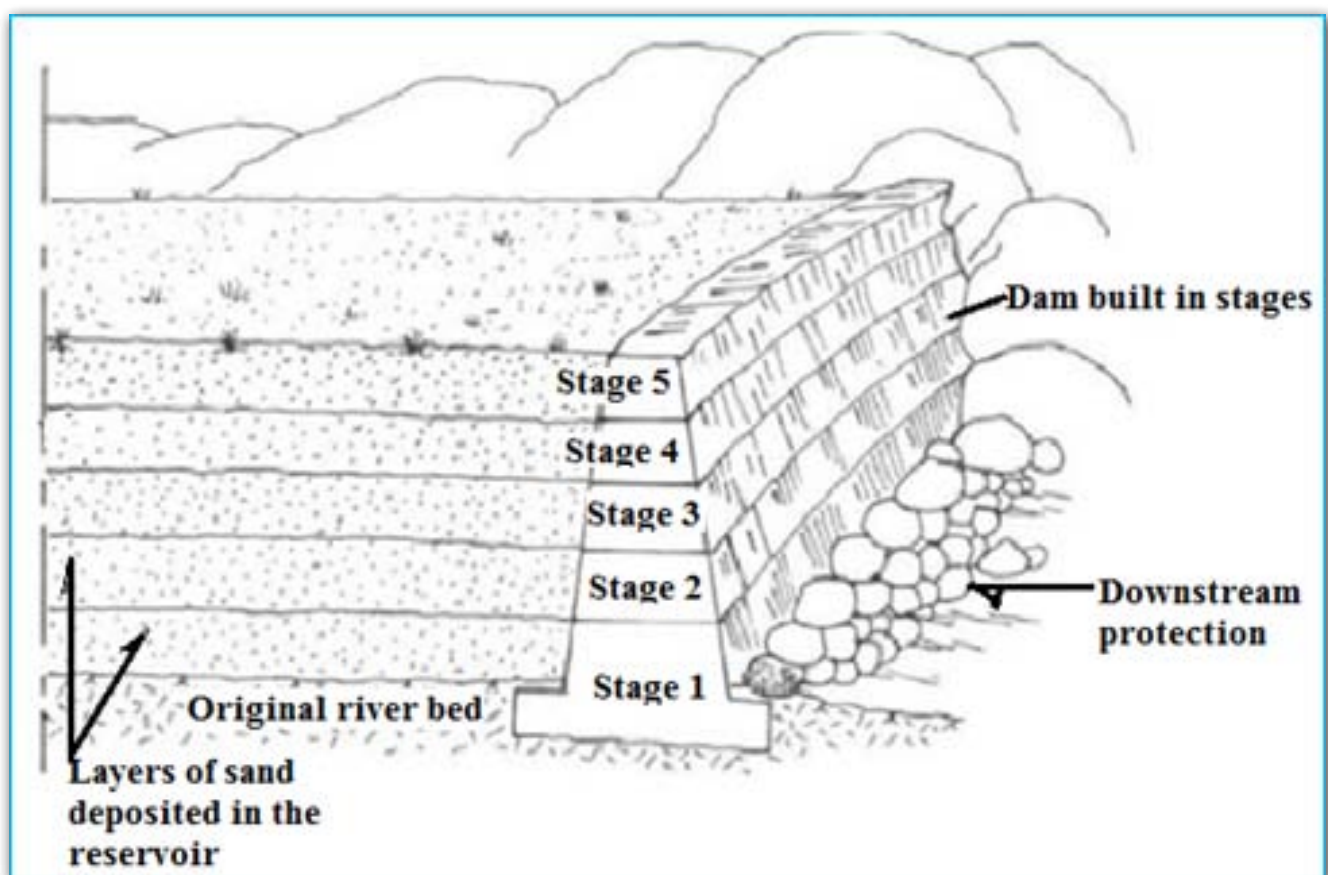

Fig 13.4 Series of construction stages for sediment storage dam

Water from sand dams can be used for different purposes like for domestic use or small scale irrigation and can be used either by digging wells at the downstream or by using hand pumps from closed wells near the sand dam.



Fig 13.5 Typical example for extraction of water from sand dams

It is also possible that an outlet pipe with a tap can be installed as a perforated pipe at the bottom of the dam just above the impermeable layer. In order to prevent entry of sand and silt, the outlet pipe should be covered fully with filter material or geo-membrane. However, the disadvantage of an outlet pipe is that it can weaken the dam structure, maintenance is complicated and it is also found to be an expensive option.

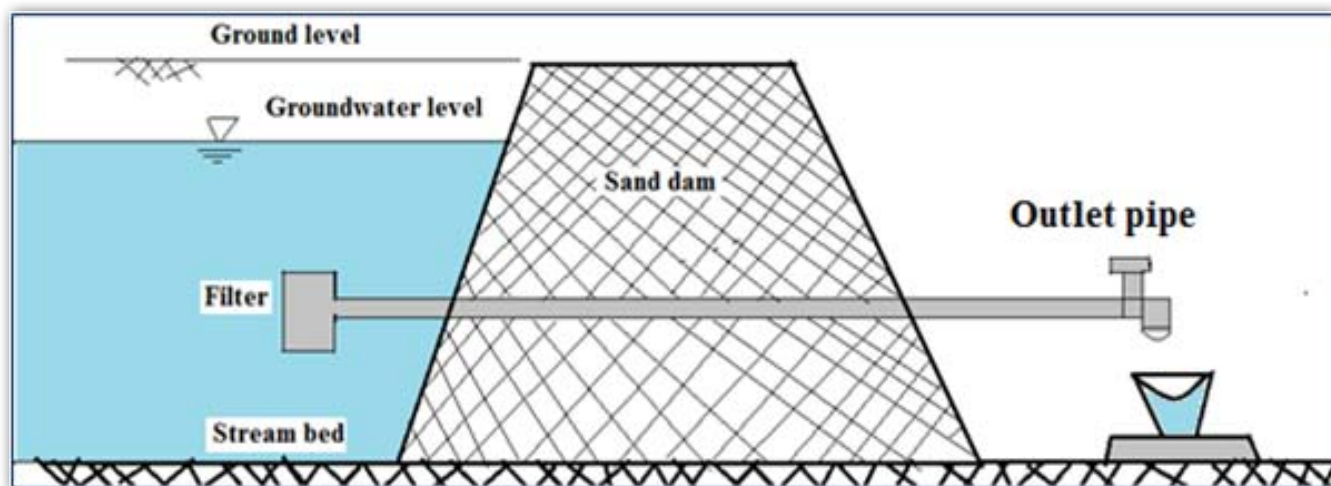

Fig 13.6 Extraction of water from a dam through an outlet pipe

13.4 Mechanisms to Collect Water from Sediment Storage Dams

When a sand dam is constructed it is necessary to excavate a trench in the sand bed in order to reach bedrock, which can be used to create a subsurface dam too. A trench is dug across the valley or stream, reaching to the bedrock or other stable layer like clay. An impervious wall is constructed in the trench, which is then refilled with the excavated material. A subsurface dam is constructed below ground level and arrests the flow in a natural aquifer. The best sites for construction of groundwater dams are those where the soil consists of sands and gravel, with rock or an impermeable layer at a few meters depth. Ideally, the dam should be built where rainwater from a large catchment area flows through a narrow passage.

13.5 Difference between Subsurface Dams and Sand Dams

As it becomes clear from the figures, the general principle of sand storage dams and subsurface dams is similar. In general, sand dams are used when the topographical gradient is high and subsurface dams are used when the topographical gradient is low. If the impervious layer lies near the surface, the storage capacity of the basin will be low. A sand storage dam will enlarge the storage, while a subsurface dam only uses the storage capacity under the surface. When the river is narrow and has high embankments, the storage capacity of a sand storage dam can easily be enlarged.

Sand and subsurface dams are common and can be built in rural areas, anywhere where there are seasonal rivers with coarse sandy sediment and where the river is underlain by impervious bedrock or clays like black cotton soil, which are common conditions in arid and semi-arid regions like Karamoja. Sand dams are more advantageous to store seasonal water resources. They protect evaporation losses, reduce contamination by livestock and other animals, filter water flowing through riverbeds, are safe against breeding of mosquitoes and other water-borne diseases causative organisms (compared to open storage ponds or facilities). Their construction is not expensive and they can be constructed with a high level of community involvement. However, the technology is labour intensive as well as physical capital intensive hence most local communities cannot implement it without external support.

Chapter 14

14. Design and Construction of Storage and Diversion Dams

14.1 Description

Storage dams are mainly to store water and use it subsequently when required for various uses such as irrigation and water supply. In designing a storage dam, consideration is given to site selection. The most appropriate site for a storage dam is where the valley is narrow, the geology is suitable for a foundation and the upstream part or reservoir area of the valley is capable of storing large quantities of water. The upstream part of the valley should be wide, have a gentle slope and a minimum permeable surface. Other important factors to be considered in line with site selection are the distance to the project area, possible alignments of the main canal, suitable site for the spillway and the environmental and social components. The site selection usually implies a comparative study of the different alternate locations. A storage dam can be constructed of earth, rock or concrete. To make sand fill and rock fill dams impermeable, usually a core of clay material is applied. If the dam is not made of concrete, the outlet structure and spillway are usually constructed separately from the dam.



Fig 14.1 A properly managed storage dam is vital to secure source of water (Kotido)

The capacity of each reservoir is fixed largely by the natural condition of the valley in which water is to be stored, and this together with the height, a dam must be able to store the quantity of water needed and economically available. The minimum dam height needed to meet the water demand in an irrigation area can be determined by making an inflow-outflow analysis for varying dam heights. An inflow-outflow analysis consists of the following steps:

- ◆ Initial water storage is assumed.
- ◆ The storage at the end of the first month is then computed. This storage equals the storage at the beginning of the month, minus the change in storage, being the difference between outflow and inflow during the month. The outflow for the month is equal to the irrigation requirements, reservoir seepage, evaporation losses and the water requirements for other uses during the month.
- ◆ If the month-end storage is higher than the maximum allowable storage, such an amount of spillage is added to the outflow so that the storage at the end of the month equals the maximum storage.
- ◆ If the month-end storage is lower than the minimum allowed storage for the dam height under study, consideration must be given to higher dam height as the dam height under study cannot meet the irrigation demand.

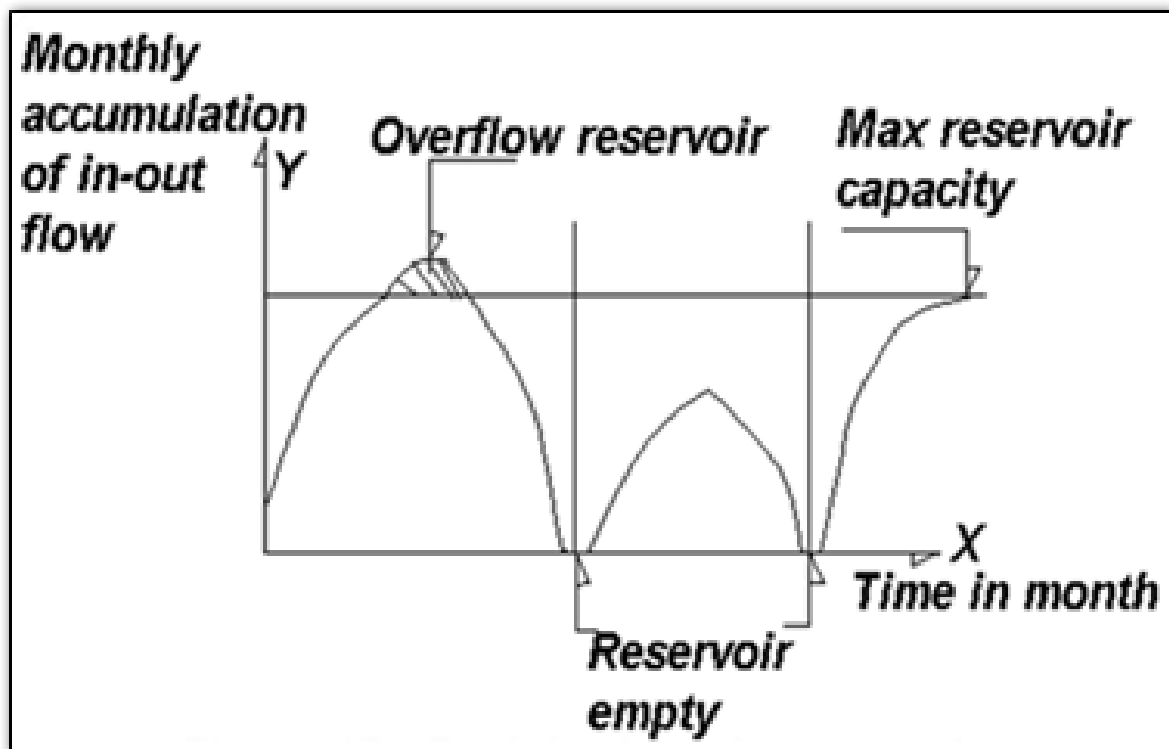

Fig 14.2 Monthly inflow and outflow measurement

- ◆ The above steps are repeated for all the months for which data are available.
- ◆ If the computations are continued to the last month, which is only possible if none of the month-end storage falls below the minimum, it must be verified whether the minimum storage is approximately equal to the minimum allowed. If that is the case, the minimum dam height has been found. If not, the storage height has to be raised or lowered.

Where Y-axis shows monthly accumulation of inflow and outflow in m³; and X-axis shows the time in month. The main advantage of an irrigation reservoir is that it provides a regular water supply, and the secondary benefits or advantages are (1) the possibility for hydroelectric power production; (2) the prevention of flooding in the downstream areas; and (3) the possibilities for recreation and fish production. Some potential problems of a reservoir are:

- ▶ As a rule of thumb, it is located in narrow upstream valley at a fair distance from the downstream irrigation area, and this implies the need for an expensive long supply canal.
- ▶ It is not suitable for small scale and/or gradual step-by-step implementation.
- ▶ It requires careful studying and planning of all related aspects, especially agricultural development.
- ▶ It requires careful staffing for operation and maintenance.
- ▶ It involves high initial investments and low revenues during the first year after implementation.

When selecting a reservoir site, several factors should be considered:

- ▶ The dam should be as short as possible and located on dry firm soil void of roots and shrubs.
- ▶ The height of the dam should be consistent with water supply, and with the economy of the project and the diversion and spillway requirements.
- ▶ Ensure that a good supply of medium-textured soil is available for the dam.
- ▶ Note that when heavy clay soil is used, the dam may crack when dry, and yet sand cannot be used because it will not hold water.
- ▶ The site should be readily accessible and should allow construction of a good spillway and reservoir.
- ▶ Consideration should be given to the hazard to life and property, which would occur in case an excess flood washes out the dam and releases the water in the reservoirs.
- ▶ The reservoir should be located on material that will not allow excessive seepage.
- ▶ Shale and rock out cropping frequently have cracks that will develop solution channels and result in serious loss of water
- ▶ Trees and shrubs should be removed from the area to be inundated.
- ▶ The size of the reservoir should be consistent with the water supply and the amount of water needed.

14.2 Spillways as a Stream Return

When the dam is built of concrete, the irrigation outlet and spillway can be combined with the dam construction or body of the dam. The purpose of a spillway is to pass flood flows without overtopping the dam wall. Particular attention must be paid to providing adequate width and depth (or freeboard) of a spillway as per the specifications given in the dam permit. All storage dams must be built with spillways large enough to convey the maximum anticipated flood flows. A spillway is a very critical segment of the design and is the feature, which frequently causes failure of dams. Design considerations for spillways must fit the site considerations. The larger the structure and the reservoir, the greater is the danger to life and property, hence the safer must be the spillway. When designing the spillway as the safeguard or safe outlet component of the main dam, the following guidelines should be applied:

- ♣ The absolute minimum width of a spillway should be designed.
- ♣ Minimum spillway dimensions are given on the permit and adequate allowance for the passage of the specified flood flows must be maintained by increasing the amount of freeboard

or increased spillway width if culvert pipes, or any other obstruction is used or required in the spillway. Specific engineering advice must be sought before changing, modifying or obstructing a spillway in any manner.

- ♣ The spillway should be cut in solid material (preferably rock) that will resist erosion. The stream return should be channelled back to the original watercourse and stabilised with a suitable size riprap consisting of rock or other materials such as gabions that will resist erosion and subsequent deposition of soil materials downstream.
- ♣ In no circumstances should a spillway be blocked or the spillway be purposely filled in to increase the capacity of the dam. The spillway of a dam is purposively designed to pass a very extreme flood. Reducing the size of the spillway increases the risk of the embankment overtopping and ultimately failing because the size of the spillway is limited to only passing smaller flood events than what the dam was originally designed for and the freeboard of the dam is reduced.
- ♣ It is the user community's responsibility to maintain the dam in a safe condition at all times including the maintenance of an adequate spillway able to pass the specified flood flows.

14.3 Freeboard

Freeboard is the vertical distance from the top of the embankment to the level of the spillway. It is, therefore, important that adequate depth be provided. If the depth is insufficient, floods will overtop the dam and the embankment material will be carried away at a progressively greater rate and extensive damage will happen. Many cases of complete dam failure have resulted from insufficient freeboard. Freeboard must not be less than the dimensions specified on the dam works permit. The absolute minimum freeboard is 0.50 metre, usually with an additional 0.25 metre to take into account potential wave action.

14.4 Description of Diversion Dams

Diversion dams are barriers constructed to raise the water level and divert a portion or all of the river water from its natural course or stream into a required direction or course. Diversion dams do not generally impound water in a reservoir. When a river has an adequate and assured flow, storage is not necessary and only a diversion structure may be necessary. In the selection of diversion dam site, the following aspects have to be considered:

- * A minimum length of the main supply canal to the irrigation areas.
- * A preferable location immediately downstream by a river bend where there are stable banks.
- * There must be a room for a desiltation basin.
- * The geological properties of the river bottom and the bank must have sufficient bearing capacity and low permeability.
- * The topography of the upstream river valley should allow the damming up of backwater.
- * There should be required hydraulic head for the gravity flow between the off take at the dam and the irrigation area below. In very flat valleys, the minimum required head may not be available, and pumping may have to be restored.

Occasionally, a dam may have a settling basin for the sedimentation of finer solids. The useful life of irrigation reservoirs may be shortened by accumulation of sediments. Once sediment has accumulated, the site is essentially of no further value for storage of water. In irrigation projects, planning allowance

should be made for the effect of sediment accumulation up on the usefulness of the reservoir and all practical steps should be undertaken to avoid sedimentation. Devices and methods used to control silting of reservoirs are silting basins, by-pass canals, off-channel locations, vegetated streams, flood sluicing, drainage and flushing. Watershed protection and special reservoir design which will allow using one or more of the foregoing means of prevention are the two most useful approaches to controlling sediment. Diversion dams are overflow dams, on which overflow spillways are constructed as part of the main dam itself by using a portion of the dam as an overflow section with crest at full reservoir level.

14.5 Spillways Design and Construction

A spillway is a structure used to provide the controlled release of flows from a dam into a downstream area, typically being the river that was dammed. Spillways release floods so that the water does not overtop and damage or even destroy the dam.

Except during flood periods, water does not normally flow over a spillway. Other uses of the term "spillway" include bypasses of dams or outlets of a channel used during high water, and outlet channel carved through a natural dam. There are two main types of spillways called controlled and uncontrolled spillways.

A controlled spillway has mechanical structures or gates to regulate the rate of flow. This design allows nearly the full height of the dam to be used for water storage year-round, and flood waters can be released as required by opening one or more gates. An uncontrolled spillway, in contrast, does not have gates; when the water rises above the lip or crest of the spillway it begins to be released from the reservoir. The rate of discharge is controlled only by the depth of water above the reservoir's spillway. Storage volume in the reservoir above the spillway crest can only be used for the temporary storage of floodwater; it cannot be used as water supply storage because it is normally empty.



Fig 14.3 Good overflow spillway masonry dam

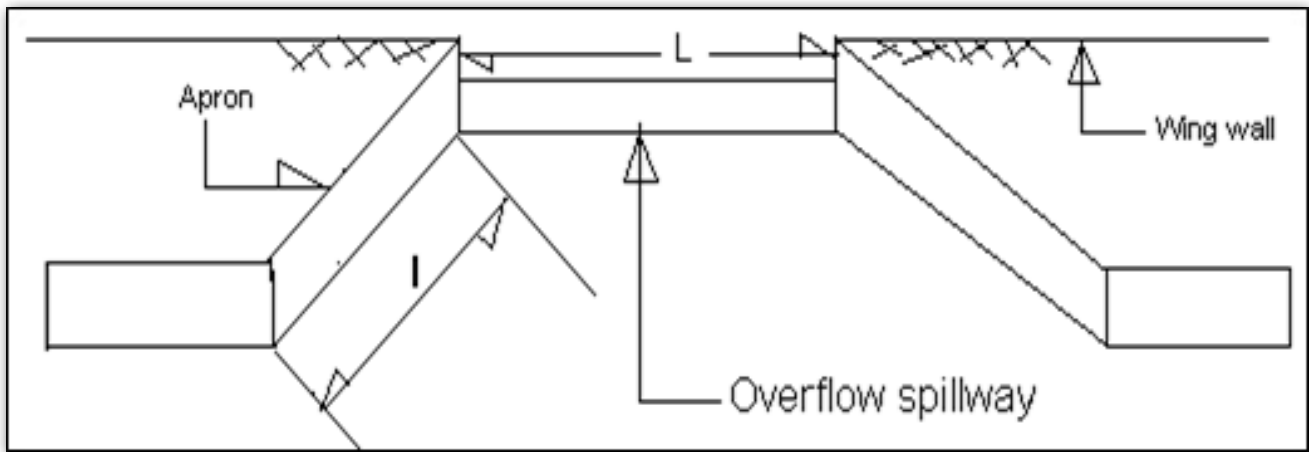

Fig 14.4 Front view of an overflow masonry storage/diversion dam

In an intermediate type, normal level regulation of the reservoir is controlled by the mechanical gates. If inflow to the reservoir exceeds the gate's capacity, an artificial channel called either an auxiliary or emergency spillway that is blocked by a fuse plug dike will operate. The fuse plug is designed to over-top and wash out in case of a large flood, greater than the discharge capacity of the spillway gates. Although it may take many months to restore the fuse plug and channel after such an operation, the total damage and cost to repair is less than when the main water-retaining structures have been overtopped. The fuse plug concept is used where it would be very costly to build a spillway with capacity for the probable maximum flood.

14.6 Spillway Design Considerations

One parameter of spillway design is the largest flood it is designed to handle. The structures must safely withstand the appropriate spillway design flood. Normally, a 100-year recurrence interval is the flood magnitude expected to be exceeded on the average of once in 100 years. It may also be expressed as an exceeding frequency with a one percent chance of being exceeded in any given year. The volume of water expected during the design flood is obtained by hydrologic calculations of the upstream watershed. The return period is set by dam safety guidelines, based on the size of the structure and the potential loss of human life or property at the downstream.

14.7 Energy Dissipation

As water passes over a spillway and down the chute, potential energy converts into increasing kinetic energy. Failure to dissipate the water's energy can lead to scouring and erosion at the dam's toe (base). This can cause spillway damage and undermine the dam's stability. The energy can be dissipated by addressing one or more parts of a spillway's design.

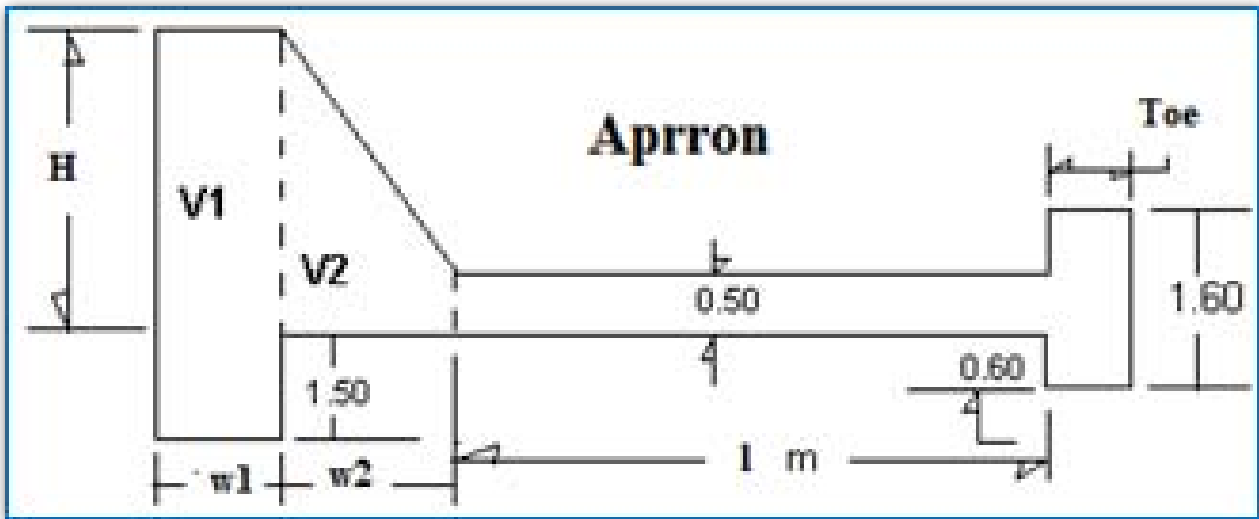

Fig 14.5 Cross-sectional view of an overflow spillway

14.8 Stilling Basin

Third, a stilling basin at the terminus of a spillway serves to further dissipate energy and prevent erosion. They are usually filled with a relatively shallow depth of water and sometimes lined with concrete. A number of velocity-reducing components can be incorporated into the design to include chute blocks, baffle blocks, wing walls, surface boils or an end sill.

Total discharge over the spillway can be computed by using the broad crested weir formula:

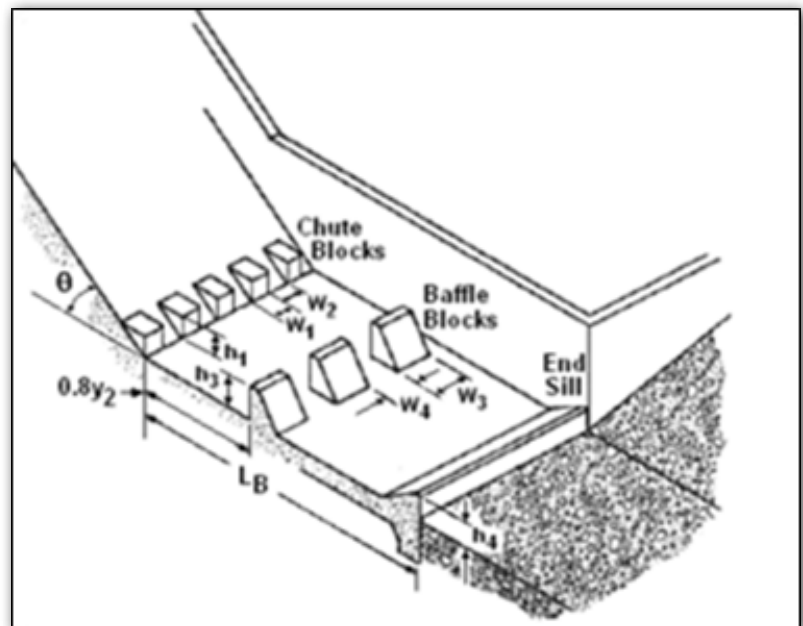

Fig 14.6 Stilling basin & energy dissipaters of overflow dam

$$q = CLH^{3/2}$$

Where:

q = is the total discharge through the weir in m^3/sec .

C = coefficient of discharge (and $C = 1.6 - 1.8$ for broad-crested weir formula).

L = effective length of the weir crest in m.

H = head above the crest in m.

Peak discharge of the stream can be calculated by using the formula of the Triangular Hydrograph Concept.

$$q_p = \frac{0.749 QA}{T_p}$$

Where:

q_p = is peak discharge in m³/sec

A = drainage or catchment area in m²

Q = depth of runoff in m

T_p = time from start of rise of runoff to peak rate in minute.

$$T_p = \frac{D}{2} + 0.6 T_c \cong 0.6 T_c + \sqrt{T_c}$$

Where D is rainfall excess period; and T_c is the time of concentration in hours.

$$T_c = \frac{(0.87 L^3)^{0.385}}{H}$$

Where L is the length of the stream in km; H is elevation difference between the upper extreme end and the dam site in meters. The length of the apron can be calculated using the following formula:

$$l = 2.2 C_b \sqrt{\frac{h}{13}} \approx 0.16 C_b \sqrt{h}$$

Where C_b is the Bligh's constant; and H is the height from apron to weir crest. The value of C_b depends on the type of foundation material.

Table 13.1 Bligh's constant for different materials	
Type of foundation material	Bligh's constant (C_b)
Sand and muddy soil	18
Fine sand soil	15
Coarse sand	12
Gravelly sand	9
Clay soil	4-6

Chapter 15

Shallow Well Design and Construction

15.1 Overview

There is water at some depth almost everywhere beneath the earth's surface. The chief potential sources of water in their approximate order of preference (based on cost, quality of water, need for equipment and supply) are springs, wells, rainwater and surface water.

A well is a dug or drilled hole that extends deep enough into the ground to reach water. Wells are usually circular and walled with stone, concrete, bricks, or pipe to prevent the hole from caving in. Wells are sunk by digging or drilling through one or more layers of soil and rock to reach a layer that is at least partially full of water called aquifer. The top of the aquifer, or the level beneath which the ground is saturated with water, is called the water table. In some areas there is more than one aquifer beneath the water table. Deep wells, such as those sunk by large motorized equipment, can reach and pull water from more than one aquifer at the same time. However, this manual will only discuss sinking wells to the first usable aquifer with hand-powered equipment

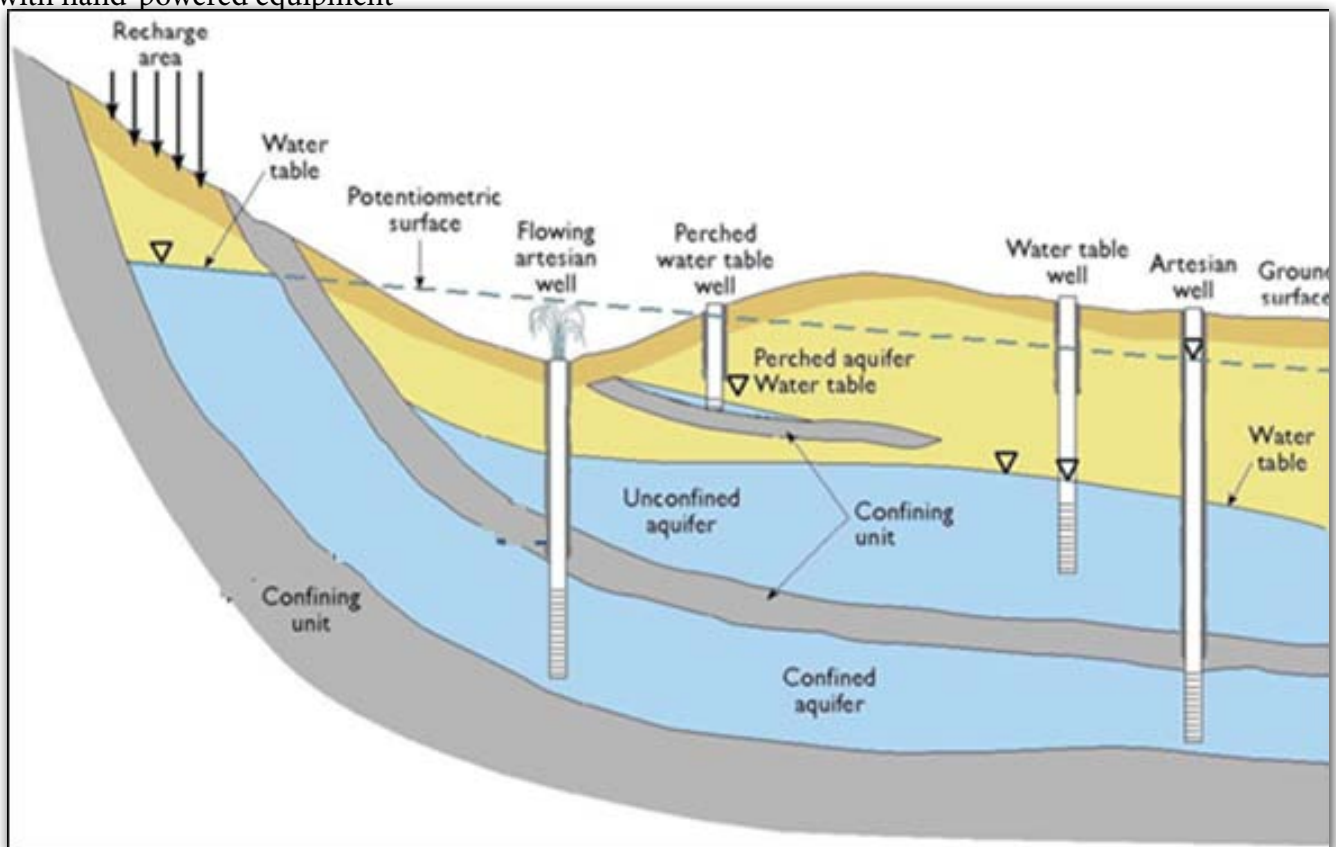

Fig 15.1: Types of aquifers and possible locations/sites of well locations

In determining the success of any well construction subproject, the degree of community participation and control may be the most important factor. In any ideal situation, the entire well digging work should be completely controlled and run by the local community. This is, however, often not possible. It, therefore, becomes the task of the district extension workers or extension agents to see that a community in need of

better water supply is encouraged to realize and act to meet this need. Some kind of organized campaign should be an integral part of every water supply improvement subproject. Unless the local communities are convinced of the benefits that clean water can bring to them and their children, they are not likely to make effective use of a newly developed water source.

When the community has decided that more and better water is needed, it will be necessary for them to decide what kind of source is possible and will best suit their needs. A well is not always the most appropriate water source in a particular locality/community.

The goal of these schemes is to find the cheapest, most reliable way to provide the needed amount of clean water. If there are year-round springs nearby, they can usually be developed to supply clean water. This water can often be conveyed through pipes without the extensive pumps or water treatment.

Because there is water at some depths, a well can be sunk almost everywhere. The water that comes into the bottom of a well has filtered down from the surface and is, in most cases, cleaner than water that is exposed on the open ground. Collection and storage of rainwater may provide another source where surface and underground water supplies are limited or difficult to reach. Normally, except in the rainiest regions, rainwater will not supply all the water needs of the local community. However, as a supplement, rainwater can be collected from roofs, or protected ground runoff areas, and stored in covered cisterns to prevent contamination.

Although streams, rivers, and lakes are all commonly used sources of water, their quality is almost always poor. Only clear mountain streams flowing from protected watersheds could be considered as fit for human consumption.

15.2 Description of Groundwater

Groundwater originates for all practical purposes from infiltration of rainfall below the root zone, either directly in the soil or in ponds, lakes and river beds. Hand-dug wells are one of the devices or systems excavated and lined by human labour, generally by entering the well with a variety of hand tools to draw or pump out this groundwater for different purposes. A hand dug well may be as small as 80 cm diameter, and in some traditional cultures as large as 15 meters diameter.

The traditional methods of obtaining groundwater in many rural areas are still the most common method, which is obtained by using hand-dug wells. However, because the wells are dug by hand, their use is restricted to suitable types of ground such as clays, sands, gravels and mixed soils where only small boulders are encountered.

The purpose of this technical manual on hand dug wells is, therefore, to make user-friendly design techniques for field staff and extension workers who are engaged in developing and maintaining ground water supplies for rural households or communities in areas where other options are restricted.

This manual brings together basic knowledge of simple techniques and technologies of upgrading simple hand-dug wells, a method ideally suited to households or groups of individuals. It is the information kit for the extension workers or villagers who are doing the job. Thus, this technical manual has been prepared for development workers who are involved in the design and construction of hand-dug wells to supply water to local communities for personal consumption, small scale irrigation and other purposes.

The manual is also useful and helpful for field workers with little or less experience to assist communities in planning, implementation and maintenance of hand-dug wells that are appropriate to the needs of the local community. This manual in general gives key guidance to extension workers in designing wells appropriate to the needs of the local community, to assess advantages or disadvantages of locally available construction materials, to decide on the most appropriate construction techniques, and to construct wells capable of meeting the needs of the community.

Though all potential situations cannot be covered, this manual indeed provides adequate background to allow extension and development workers to assess situations and determine what available techniques might be useful to apply.



Fig 15.2: Simple and local hand dug well construction technique

15.3 Advantages and Limitations of Shallow Wells

Rural communities have frequently employed hand-dug wells to increase the supply of water available for community as well as individual uses.

Using simple construction techniques and suitable materials, hand-dug wells can provide reliable sources of water and offer the following advantages:

- * Because the community can be involved in the actual construction process, it is their own asset, which they are more likely to maintain.
- * The equipment needed is light, simple and thus suitable for use in remote areas.
- * The construction techniques are easily taught to unskilled workers, thus cutting cost and time for supervision.

- * With the exceptions of cement and reinforcement, the necessary materials are usually locally available, making it one of the cheapest methods of construction of wells in rural communities.
- * A complete well provides a reservoir at the source which will accumulate and store water from aquifers that would otherwise be too weak to use.

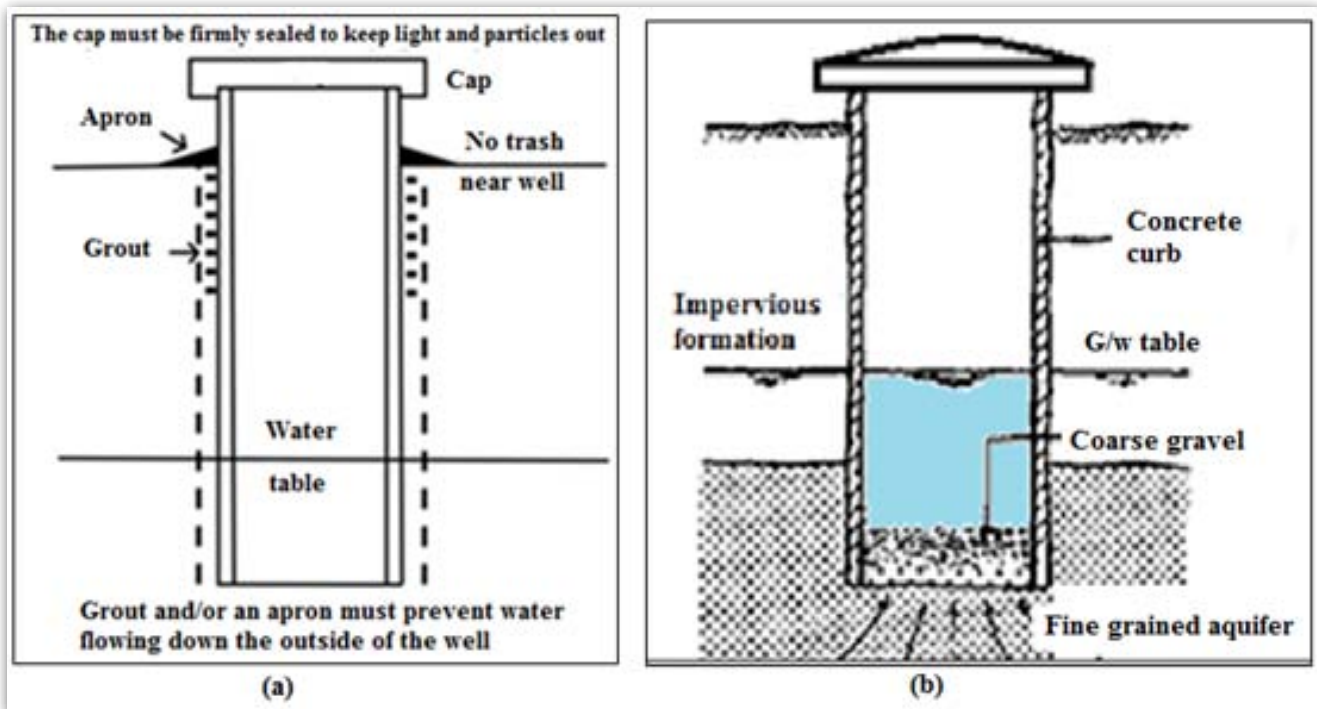

Fig 15.3: Hand dug well with a firmly sealed cap

On the other hand, shallow hand-dug wells have the following limitations:

- * Sixty meters is usually the practical limit to the depth that can be reached, although most dug wells are less than 20 meters deep.
- * Depending on the availability of labour, construction is slow.
- * Extracting large quantities of water with motorized pumps is not feasible.
- * Hard rock is very difficult to penetrate and often can only be accomplished by blasting, which is slow, hard work.
- * Because it is difficult to penetrate very far into the aquifer, slight fluctuations in the water table often make hand-dug wells unpredictable and unreliable.

A hand-dug well is the only method of well-construction where people actually go into the well to campaign, demonstrate and explain what each part of the well is and how it works to help villagers understand and then want to work together and maintain it more. In so doing, proper maintenance necessary in keeping the well-functioning is likely to be better carried out, particularly in communities using a well or an improved water source for the first time. If installed on a hand-dug well with a full cover, a pump will help reduce chances of contamination significantly. In rural areas where pump maintenance and repair can be a real problem, large diameter wells are often the best solution to water supply problems. Pumps can be installed while leaving access through which water can be drawn by rope and bucket if the pump should break down (See Fig 14.4).

Compared to other well sinking methods, digging a well by hand takes a long time. An organized and experienced construction team consisting of five workers plus enough people to lower and raise loads in the well can dig and line one meter per day in relatively loose soil that does not cave in. However, the bottom section is likely to take 2 or 3 days per meter because of the difficulty in working while water continually enters the well.

Depending on how the designer plans to develop the well, the top section can take a day or two to several weeks. An experienced team sinking a 20 meter well and installing pulleys on the top structure could easily take 5 weeks, including occasional days off (this, of course, assumes no major delays). A new or inexperienced group would be expected to take twice that time.

Hand-dug wells should be dug during the dry season when the water table is likely to be at or near its lowest point. The well can be sunk deeper with less interference from water flowing into it. The greater depth should also ensure a year-round supply of water. If the well cannot be dug during the dry season, plan to go back to deepen it at the end of the dry season.

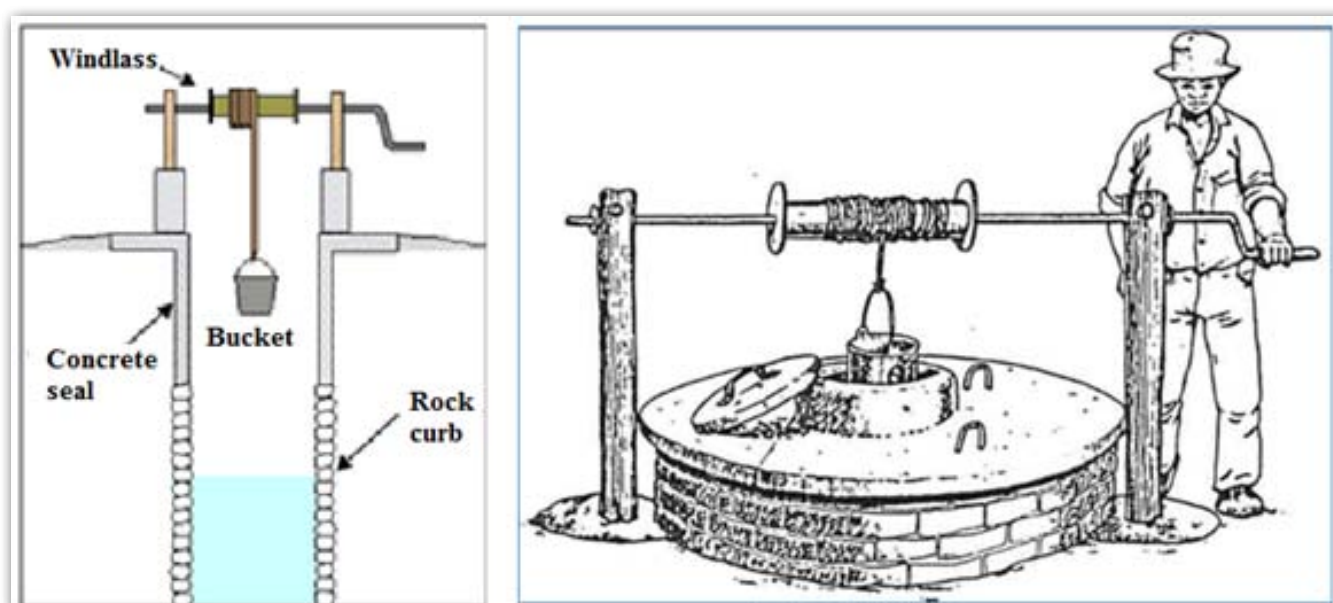

Fig15. 4: Manual methods to draw out water from hand dug wells

15.4 Participation of Community in Site Selection

Though this technical manual can be used as an everyday field guide for those performing the work, it is recommended that whenever possible, appropriately skilled local individuals, or agencies are encouraged to provide technical support to the field staff to perform the work. However, if skilled workers are not available, the manual can be used to guide the local extension workers and communities to provide the basic skills and services in exploiting groundwater resources. It is mandatory that community members are involved in the selection of the site and should be guided in site selection by the technical personnel of the district and the implementing agency. Planning of hand dug wells should also first consider preference and choice of community (particularly women). If the preferred sites are not suitable for some technical reasons, this must be explained to the community and alternative locations should be proposed for consideration.

Every dug well should be located in an area that is:

- ♣ At least 30 meters from any part of a human waste disposal area (for example, septic drain field, latrine).
- ♣ At least 15 meters from any food or related wastewater disposal area (for example, kitchen and/or laundry wash water disposal areas).
- ♣ At least 30 meters from any confined animal feeding areas, animal housing or manure storage.
- ♣ At least 150 meters from any solid waste landfill or chemical or industrial waste disposal area.
- ♣ At a higher land surface elevation of the preceding identified areas whenever possible (if the groundwater flow direction is known, at a location of higher groundwater head).
- ♣ Reasonably accessible to the beneficiaries if it is also the point of water distribution for individual households or communities.
- ♣ Protected from contamination from wild and open-range animals and livestock (see Fig156).



Fig 15.5: Manual hand dug well construction

- ♣ Outside of floodplains and areas prone to regular flooding from surface rainwater drainage.
- ♣ Close to power if the well is to be connected to an electric pump.
- ♣ Protected from damage, and reasonably available for future servicing of the well.

15.5 Preliminary Groundwater Survey

The main objective of a preliminary groundwater survey is to minimize the cost of groundwater development. Planning a preliminary groundwater survey should include minimizing the total cost of study and implementation of the groundwater development project. It is essential to keep this concept in mind in order to avoid oversizing the study in relation to the expected final groundwater development.

The importance of the exploration phase of the subproject should not be neglected, particularly in areas of discontinuous aquifers where little information is available. The results to be expected from a preliminary survey are:

- ♣ Identification of aquifers and estimation of their characteristics. This assessment survey includes geological setting, hydraulic continuity, groundwater quantity and quality assessment and expected water demand, depth of water table from the ground surface, and physical characteristics of the formation to be penetrated to reach water or water table.
- ♣ Identification of appropriate development methods, which include performance of dug or drilled wells; well depth, diameter, and where wells are open to aquifer; construction methods; technical specifications; use of local or imported techniques; and overall costs.
- ♣ Selection of pumps or water lifting devices.
- ♣ Assessment of the risks of failure



Fig 15.6: Shallow well with proper area drainage system

A preliminary survey may identify the groundwater conditions, and taking these and other conditions into account, a reasonable basis for choice of groundwater development may be obtained. Identifying groundwater conditions includes determining the location and physical properties of the aquifer, estimating the quantity and quality, and determining depth to the water table from the surface. The groundwater conditions will determine what kind of wells may be constructed. Depending on these possibilities and on the local resources and economics, costs are compared and a reasonable choice may be made. Finally, typical technical specifications for the wells and pumps may be prepared.

15.6 Methodology for Preliminary Hydrogeological Survey

In reviewing existing geological and hydrogeological information, geological and hydrogeological maps of a scale ranging from 1:200,000 to 1:1,000,000 can provide essential information on aquifers, their extension, boundaries and lithology, and depth to water level.

This information is usually sufficient to determine whether or not the aquifers are continuous within the area considered for the livestock water supply project and domestic uses.

In addition to these geological and hydrogeological maps, satellite images may provide complementary information on geological formations and structures. Aerial photographs may also be necessary and geophysical surveys need to be available. In addition, information from an inventory of water wells is the basis for a more accurate identification of the aquifers which will then be tapped in the framework of the future groundwater development subproject.

From the data collected on the existing dug and drilled wells it will be possible to establish the hydraulic continuity of the aquifer and to map the depth to water, the distribution of the good wells and water quality. In the case of discontinuous aquifers, the data collected should also include dry wells (dug or drilled) in order to establish a correlation between as many parameters as possible. Dug well discharge is usually correlated with the:

- ♣ nature of the water-bearing formation;
- ♣ formation fracture characteristics, if any (from air photo interpretation);
- ♣ distance to important tectonic structures (from satellite imagery and air photo interpretation);
- ♣ depth of penetration of the wells into the aquifer.

This information would be collected by the service responsible for the Water Resources Inventory, like Ministry of Water and Environment, in which case the additional field investigations required will be limited to updating the inventory or checking questionable information.

15.7 Selection of types of Wells and their Construction Phases

The first factors to be considered for selecting the type of well and pump are the expected depth to water and depth of the well. When both depths are less than 10 m the most suitable solution in pastoral areas consists of digging wells from which water will simply be extracted by hand or animal powered lifting devices

At the other extreme, when both depths are greater than 70-80 m the only solution consists of drilling wells (boreholes) which will be equipped with motor driven pumps. In between these two extremes all solutions are possible and other criteria have to be considered to decide whether to dig or to drill the wells and which pumps to install on the wells.

When the water table is relatively shallow, wells are dug by local community when the formation is soft. Even in the harder rock, use of hand methods to break out blocks of rock can be relatively inexpensive provided the labour is provided by the community. The unit cost per meter for digging and lining large diameter wells depends on the depth of the wells, the hardness of the formation, the difficulty of access and the distance from the capital.

In discontinuous aquifers, it is always necessary to drill a reconnaissance borehole to ascertain the presence of water before digging a well, and the cost of the drilling should obviously be added to the construction cost of the dug well. However, in the following examples dealing with groundwater development programmes in discontinuous aquifers, the cost of the reconnaissance boreholes will not be considered.

In dug well method the hole is constructed by digging to the desired diameter and depth with hand. The dug out materials are removed by lifting them from the hole in some type of container. The hole is shored, lined or cased as the depth is increased. One of the limitations of the traditional well digging is the difficulty of penetrating far enough into the aquifer to ensure an adequate depth of water in the well at all times in the future.

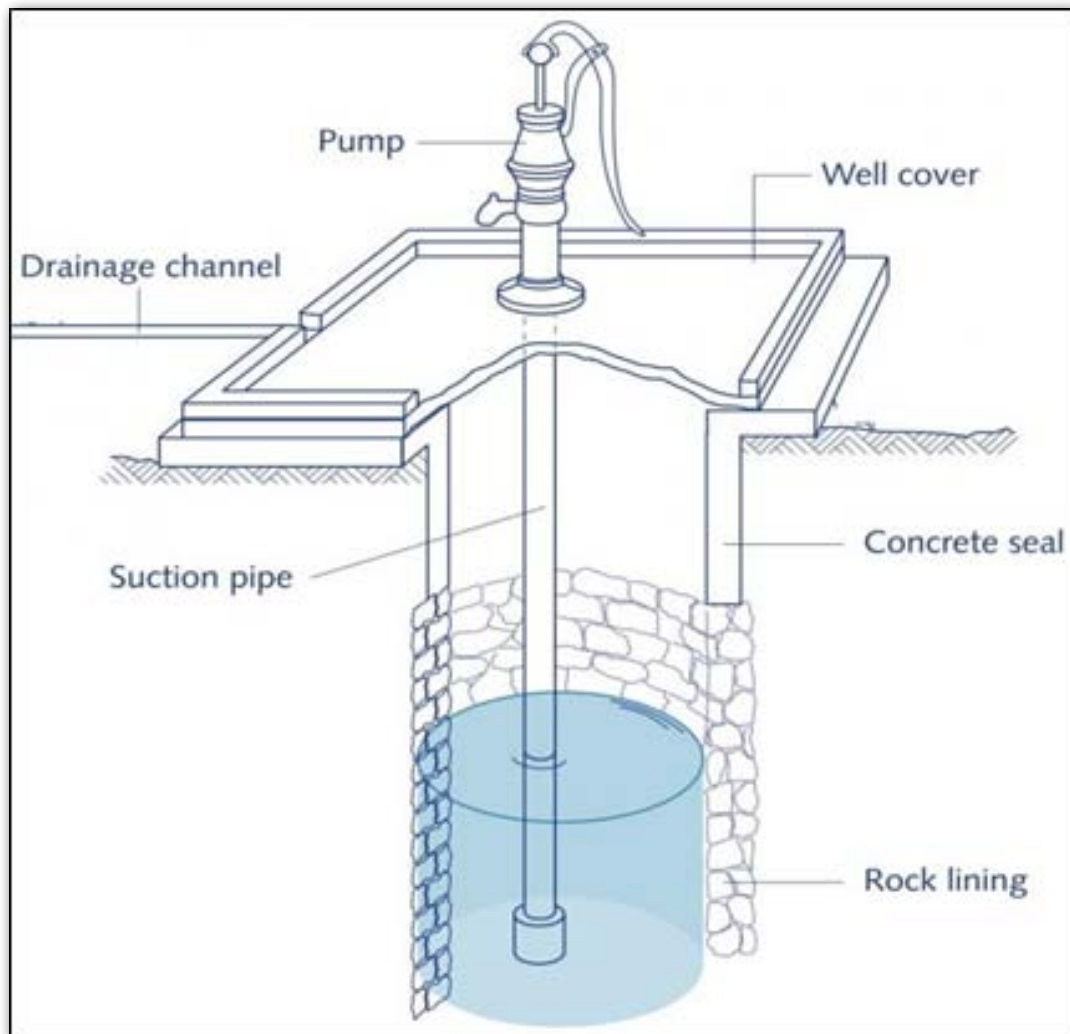

Fig 15.7: Profile and sectional view of a hand dug shallow well

The difficulty is made worse by the fact that the water table fluctuates seasonally and may even drop considerably at the end of a long dry period. These wells are manually dug holes in the ground (using shovels, picks, etc.) with the exception of modern wells. They are generally not very deep (between 8 and 20 meters). Because they are so shallow, these wells are at higher risk for contamination. Wells are often relatively easy ways to obtain water, particularly in areas that lack surface water. Their construction is an economical technique because it only requires physical labour with simple hand tools. Hand-dug well construction can be broken down into several phases:

- ◆ digging through dry earth: this means making a cylindrical hole from the surface down to the level of the water table;
- ◆ constructing the casing (a lining that reinforces the walls of the well);

- ◆
- ◆ setting up the mechanism for abstraction: this is the part of the well that is below the level of the water table that allows water to enter the well;
- ◆ installation of surface material to keep the well in good condition and preserve the quality of water that comes from it.

15.8 Traditional and Permanent Wells

Traditional wells are construction structures made by local community with the means that they have at their disposal, sometimes with the help of professional well-diggers. These wells are dug by hand using very old methods, without concrete spouts, with walls only supported with wood or branches.

Temporary digging: These small wells are generally less than 10 m deep. They are constructed simply and quickly with a simple lining of branches or straw. They must be regularly reinforced because they can cave in. The depth of the water in them is generally shallow, and **the volume of water they supply is low.**

Permanent Wells are **deeper** (sometimes as deep as **10-20 meters or more**) and are made by experienced well-diggers. **Their diameter varies from between 0.8 and 1 m.** While the lifespan of wells like these is longer than for temporary wells, **they may deteriorate significantly** if the support for the well walls is not substantial enough.

Modern Well: This type of well can be dug partly by hand but it is generally done with mechanical digging equipment. The diameter of these wells varies between 1.0 m and 1.8 m. The walls are firmly supported by a metal or concrete casing, topped with a coping and protected from animals. The digging techniques vary depending on the nature of the soil: (1) in soft soil (sand, clay, soft schist) - manual tools like shovels, picks and crow bars can be used; (2) in harder soil (sandstone, hard schist, etc.) - a jackhammer is needed; (3) in very hard soil (granite, quartz) - explosives can be used but this is an expensive and dangerous technique. In these situations, drilling is a better technique to be applied/used.

15.9 Advantages and Drawbacks

There are multiple dangers (cave-ins, falling walls) when a well is dug by hand. A certain amount of knowledge, skills and understanding of the technique are absolutely necessary to ensure the safety of the people working on its construction.

Advantages: Wells dug this way have a wider diameter which means water can be drawn from a wider zone in the water table. These wells can capture water from less permeable materials such as fine sand, loam or clay.

Drawbacks: they are generally **fairly shallow**, which means they can be contaminated from the surface; most surface wells are not very deep and they are dug in permeable soil so they **can quickly run dry in a drought** or with a simple seasonal drop in the water table if it goes below the depth that the well reaches.

15.10 Technical Specifications for Well Construction

The site should be cleared for a 5 m radius of the well center point, and the ground within this radius should be levelled and barriers set up to demarcate the construction area. The layout of the construction site should allow for easy access to the well for moving the materials, for easy and appropriate disposal of the soil excavated from the well, and for the rapid and safe disposal of the water when dewatering.

The center point of the well should be located where water can easily drain away and the well radius (0.90 m) drawn on the ground around the center point, giving an excavation diameter of 1.8 m. The soil should be excavated down to 90 cm and a shutter inserted to hold the top soil from collapsing. The well should then be excavated to a depth of 5 m or to the top of water table, whichever occurs first. A plumb bob should be used by the supervisor to ensure the verticality of the well.

Unless the soil is particularly stable, it is not advisable to excavate further without lining. Shutters of 1.6 m diameter should then be placed in the reinforcement bars, both vertical and horizontal, are placed behind the shutters and concrete poured in at 1 m lifts. The reinforcement steel bars should be 6 mm for vertical rods and 6 mm for the horizontal rods and the concrete mixed in the ratio of 1:2:4. If possible excavation should proceed at least 3.5 m below the water table.

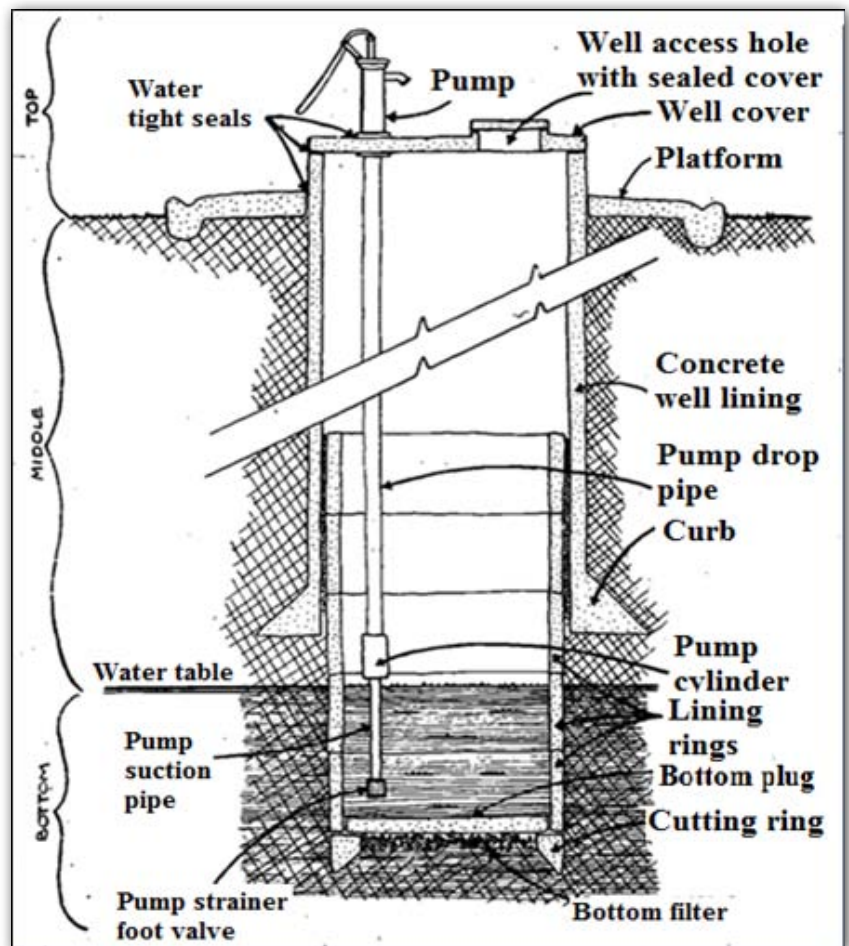

Fig 15.8: Cross section and profile of a dug well

15.11 Construction of head wall, apron, drainage channel and cover slab

The head wall is an extension of the well lining and should extend 300 mm above ground level. The apron is meant to provide a clean and well drained area around the well. To ensure good drainage, the surface of the apron slab should be 100 mm above the ground level. It should have a gradient of 1:20 towards the drainage channel and a radius of 1.5 m around the well. It should be cast with concrete mixed into ratio of 1:2:4 (cement/sand/gravel) reinforced with 6 mm horizontal and radial steel rods. It should be allowed to cure for 21 days.

The ground immediately around the apron slab should be covered with a layer of stones to prevent the soil becoming muddy, and the soil around the slab eroding away and undermining the edge of the slab. When the apron is being cast data about date of completion, depth of the well and static water level should be inscribed into the wet concrete in an area that will not be easily eroded.

The drainage channel should be 4 m long, 200 mm wide and 50 mm deep. It should terminate in a soak away pit of 400 mm x 400 mm x 400 mm. The cover slab, well fitted with a hand pump, should be the exact diameter of protruding well head, that is, 1.8 m (the internal diameter is 1.6 m plus 10 cm concrete wall on each side).

The construction of the cover slab has to be coordinated with the pump installation as the pump stand has to be imbedded in the cover slab. It should be 100 mm thick, reinforced with 8 mm steel rods at 150 mm grid, concrete mixed in the ratio of 1:2:4 and allowed to cure for 21 days. It should incorporate a manhole of 400 mm x 400 mm, fitted with a lockable steel lid set in a frame and hinge style so that it can be opened if the pump breaks down and bucket and rope can be used to fetch or draw water. It also permits groundwater monitoring and well inspection. The cover slab for wells using a rope and bucket is the same as described above, except that it should have a 400 mm x 400 mm lockable metal lid set in a frame and hinge style in the center of the slab. On completion of the works, the area around the well should be levelled and all material and equipment removed. It is mandatory that the well area must be fenced off with a lockable gate. However, the materials to be used and designed should be left for the community to decide.

15.12 Estimating the Water Yield of a Well

A well fitted with a hand pump is expected to give a yield of at least 100 lt/hr. This should be established by conducting a three-hour pumping test. The yield can be measured with a flow meter on the discharge pipe or by timing how long it takes to fill a container of known volume. At the same time, the drawdown in the well should be monitored using a deep meter. Another method is to pump out the water and monitor how long it takes to recover. If the recovery is very low it may not meet the demand.

15.13 Cost and Maintenance Requirements

Construction, operation and maintenance costs depend on the techniques and the pump system used. For construction costs, it is needed to take into account digging (labour, drilling equipment, etc.); material used for the lining; any pump equipment necessary (hand pump, or motorized pump). Many wells are only equipped with a pulley and a well-bucket attached to a rope. These costs vary considerably depending on the materials used and their availability.

The ideal water lifting device for groundwater production in rangeland areas, in arid and semi-arid areas, should be capable of: (1) delivering a minimum of 20-30 m³/day; (2) delivering the amount necessary to meet the daily requirements of 500 - 700 cattle; and (3) be operated by only one person, if necessary, should require little or no maintenance. In fact, there are no devices which can meet all these conditions and the solutions proposed can only take into consideration one or two of the above conditions and be as close as possible to the third one. For example, hand water lifting does not require any maintenance, it can be carried out by one person but can deliver 20 m³/day only under very restrictive conditions, that is, water level depth not exceeding 10 m and 5 to 6 people drawing at the same time. It is clear that the type of water lifting method should suit the type of well (dug or drilled) already existing or planned.

Chapter 16

Spring Design and Construction

16.1 Description

The geological definition of a spring is a natural flow of water from the ground or from rocks, representing an outlet for the water that has accumulated in permeable rock strata underground. A spring is a place where groundwater naturally seeps or gushes from the earth's surface. Spring water typically moves downhill through soils or through cracks and fissures in the bedrock until the ground's surface intersects the water table. Some of the water that falls as rain soaks into the soil and is drawn downward by gravity to a depth where all openings and pore spaces in the rock or soil have become completely saturated with water. Thus, this zone is called the zone of saturation, and upper surface of the zone of saturation is called the water table. Above the water table lies the zone of aeration, where the pore spaces in the soil are quite dry and are filled with air.

When the upper surface of the groundwater (water table) intersects a sloping land surface, a spring appears. The occurrence of springs is closely related to the geology of an area. If an impervious layer of rock, such as a clay deposit, underlies a layer of saturated soil or rock, then a line of springs will tend to appear on a slope where the clay layer outcrops. Springs can be a valuable water source, and improvement in flow can often be accomplished simply by driving a pipe into the ground at the point where water seeps from the ground.

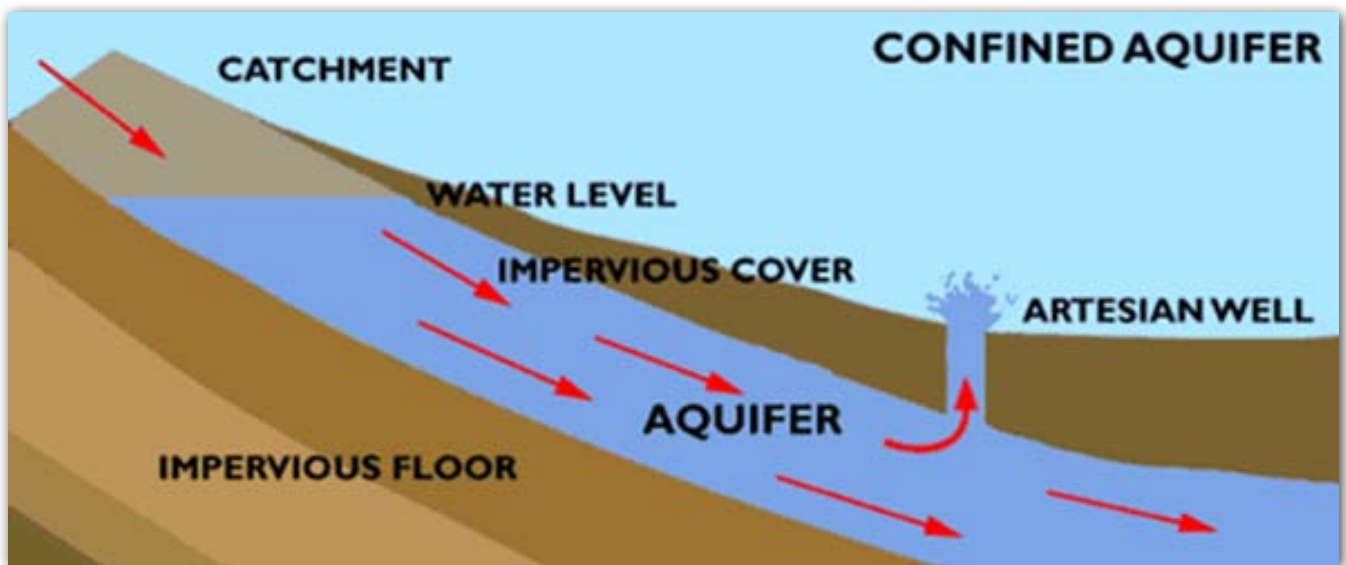

Fig 16.1: Profile of a confined aquifer and emergence of a spring

Springs are classified in several ways. The two general types of springs are Artesian and Gravity springs. An artesian spring occurs when the groundwater, under pressure, finds its way to the land surface (see Figures 16.1, 16.2, 16.3).

Fig 16.2: Formation of Artesian spring

An artesian spring flows because the pressure in the aquifer (water bearing soil or rock), which is covered by a confining layer (clay or other impervious material), is greater than atmospheric pressure at the land.

A spring is formed when the water reaches the surface through a fracture or porous layer. These types of springs usually occur along faults (a fracture in the earth), or in areas of great topographic relief such

as cliffs or valleys. Artesian springs occur when water under pressure is trapped between two impervious layers. Because the water in these springs is under pressure, flow is generally greater than that of gravity springs. Artesian fissure springs are similar to fracture and tubular springs, in that water reaches the surface through cracks and fissures in rocks. These springs make excellent community water sources because of their relatively high flow rates and single discharge points.

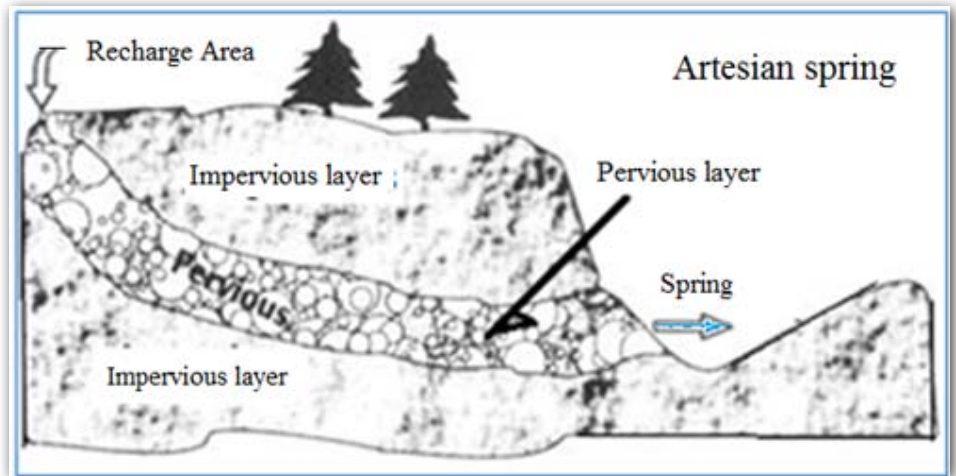

Fig 16.2: Formation of Artesian spring

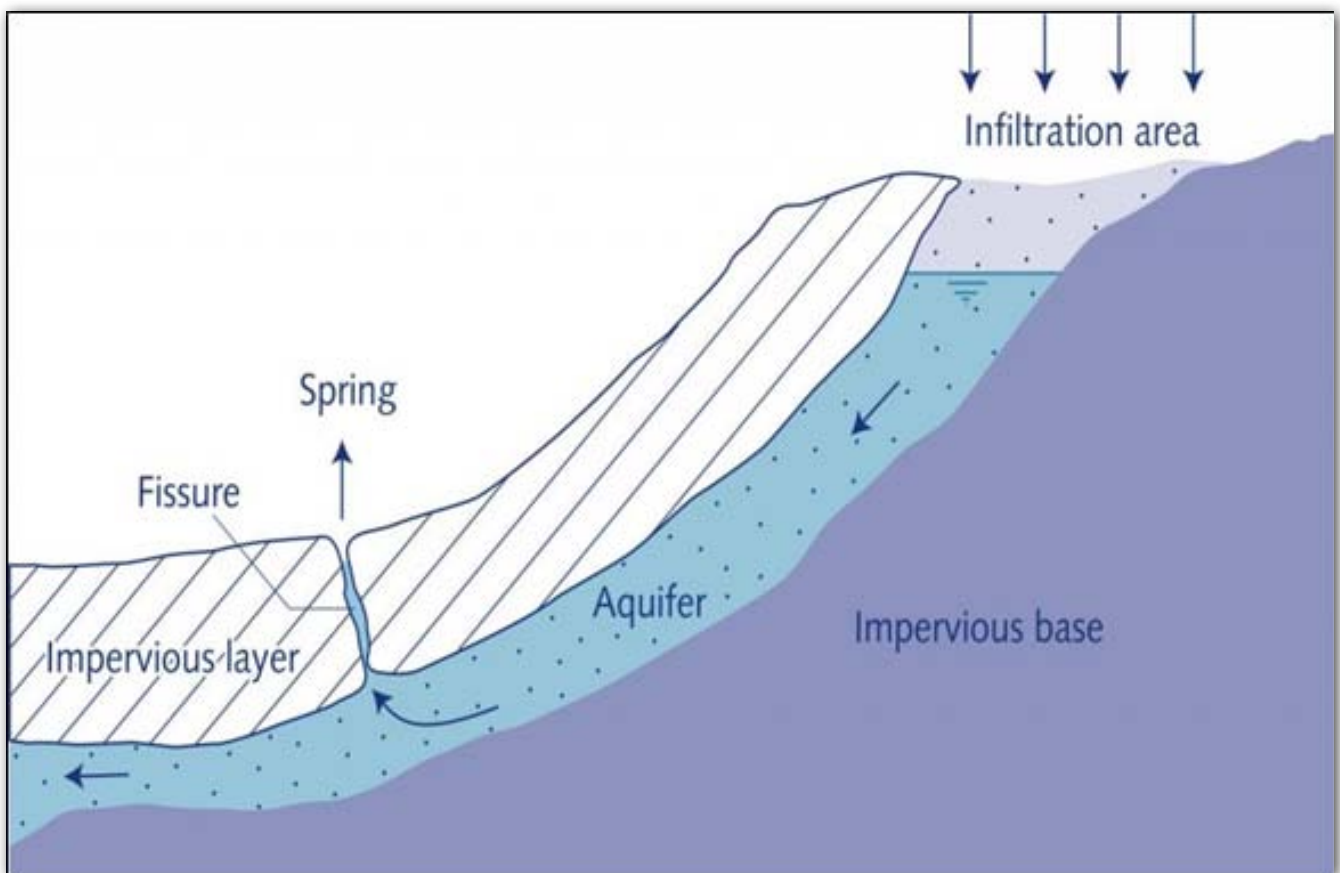

Fig 16.3: Hydrological formation and aquifer emergence of a spring

Another type of artesian spring that can be developed as a high quality water source is the artesian flow spring.

These occur when water confined between two impervious layers emerges at a lower elevation (see Fig 16.2). Artesian flow springs often occur on hillsides, making protection a fairly easy process.

A gravity spring is formed by water soaking into the ground until the water encounters a confining layer that will not let the water seep further down. The water then flows across the top of the confining layer until it reaches the ground surface. Examples of gravity springs are springs found in hillsides or cliffs (see Fig 16.4). Gravity springs include depression springs, contact springs, and fracture or tubular springs.

Depression springs occur when the land's surface dips below the level of the water table. Yield from depression springs is highly variable, depending on the level of the water table. In areas that experience a pronounced dry season, depression springs may not be a suitable source of drinking water if the water table drops below the level of the depression, causing the spring to become seasonally dry. Gravity contact springs occur when an impervious layer beneath the earth's surface restricts surface water infiltration. Water is channeled along the impervious layer until it eventually comes in contact with the earth's surface. This type of spring typically has a very high yield and makes a good source of drinking water. Fracture and tubular springs are formed when water is forced upwards through cracks and fissures in rocks. The discharge is often concentrated at one point, thereby facilitating the process of protecting the source.

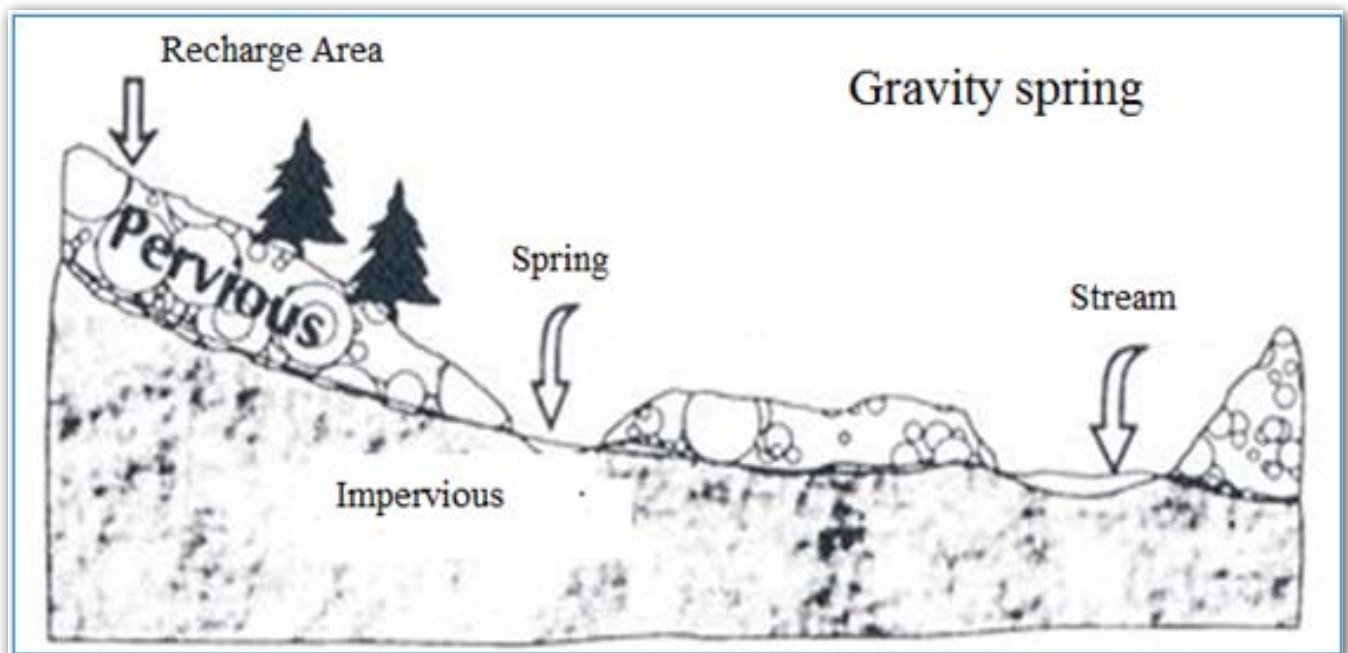

Fig 16.4: Formation point of a gravity spring

16.2 Discharge Rate of Flow

Springs with a significant flow of water, say over 20 m³/h, were developed long ago and are currently used for either irrigated agriculture or human needs, but smaller flows are often overlooked as potential sources of water for livestock consumption, mostly in arid and semi-arid areas where a small water flow immediately evaporates if not properly collected and conveyed.

A spring discharging less than 0.5 m³/h does not usually show any flow. Water disappears by evaporation and evapotranspiration in the middle of the vegetation which naturally develops around the spring. Small springs usually occur as outflows of catchment basins of limited extension and with poor hydraulic characteristics in mountainous areas. A simple and accurate way to determine flow volume of small water supplies is the 90° 'V' notch.

The most accurate method of measuring small discharges is by observing the time required to fill a container of known capacity, or the time required to partly fill a calibrated container to a known volume. The basic equipment needed is a calibrated container and a stopwatch.

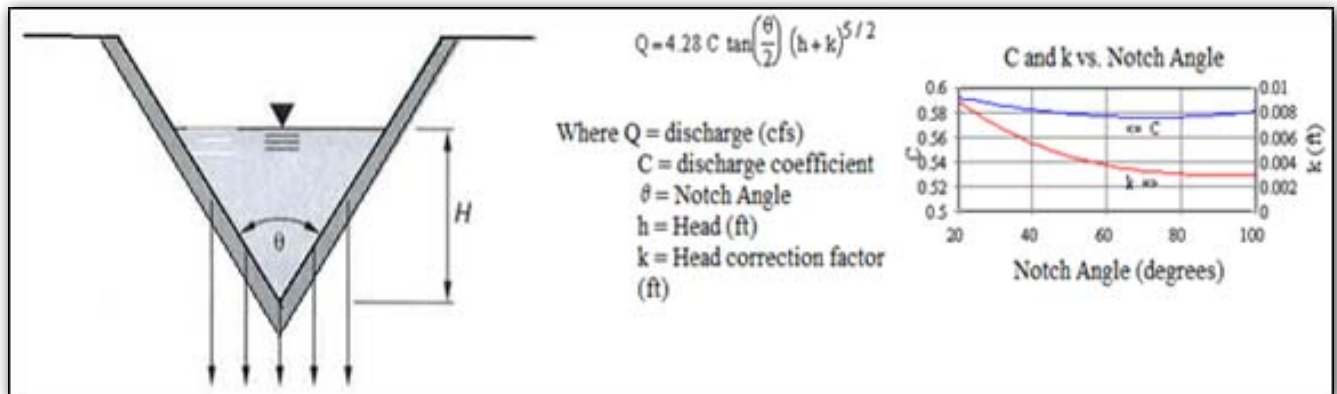

Fig 16.5: Measurement of discharge through a 90° 'V' notch

Calibration is done by weighing the container with varying amounts of water in it and noting the depth of water in the container. Volumetric measurements are made under a condition when the flow is concentrated or can be concentrated so that all of it may be diverted into a container or the measurement of flow can be diverted through the V-notch. The measurement is made three or four times to be certain and to be sure the result is consistent.

A 'V' notch suitable for determining flows up to 10 m³/h can easily be made from a piece of flat metal measuring 40 cm x 25 cm from which a triangular notch with a right angle has been cut out (see Fig 16.5, Fig 16.6). The positions of the graduation referred to at the bottom of the notch are as follows:

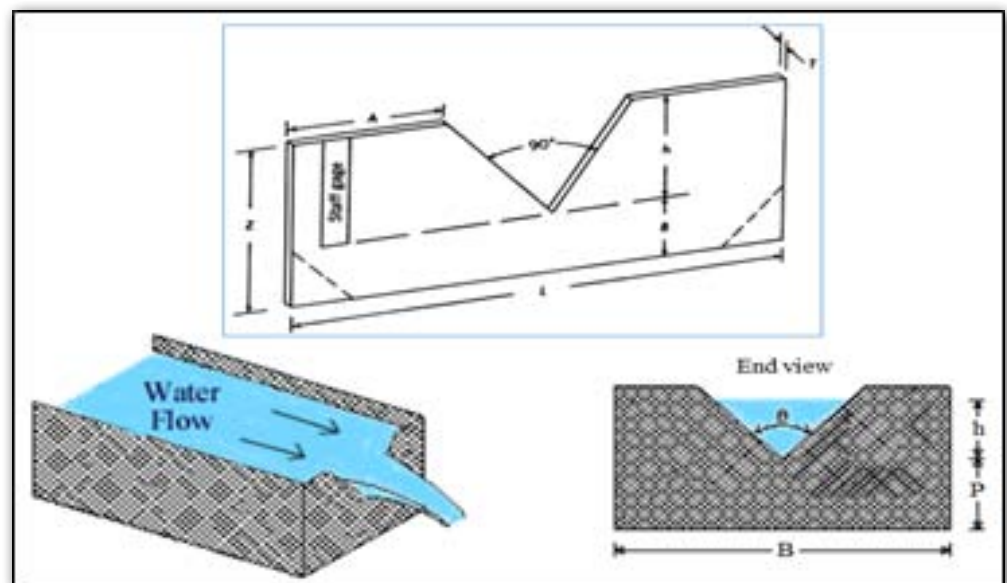

Fig 16.6: Spring box with tight cover to measure volume of discharge

The most important point to remember is "DO NOT increase the water level of the spring". The normal water level of the undisturbed spring should be marked and no attempt should be made to increase or lift this level for any reason. If the water level is increased, the extra pressure may cause the spring to flow out through another outlet which may be far away from the present one.

Flow or discharge rate through 900 V-notch can also be estimated using the following equation:

$$Q = 2.49h^{2.48}$$

Where:

Q = flow rate in cubic feet per second (cfs).

h = Height of the upstream water above the bottom of the weir in feet.

16.3 Spring Water Protection

The main objective of spring development and protection is to provide improved water quantity and quality for human consumption. Before reaching the surface, spring water is generally considered high quality, depending on the composition of the surrounding soils and bedrock. However, groundwater can become contaminated as it exits the ground's surface. Contamination sources include livestock, wildlife, crop fields, forestry activities, septic systems and fuel tanks located upslope from the spring outlet. Therefore, spring water sources need to be protected at the source or eye. Just as there are many types of springs, there are also many different kinds of protective structures, such as spring boxes, seepage spring development structures, and horizontal wells.

Spring boxes are typically cheaper, require the least skill, and can be made with locally available materials. In contrast to the generally held belief that discharges decline if the springs are touched, the development of natural springs often leads to improved yields. A spring includes the following main components:

- ♣ **Collection box (also called a spring box):** A box made of concrete, fiberglass, galvanized steel, or other material approved to be in contact with potable water that collects spring water. It may be sealed and buried, or it may extend above grade and have access for inspection and disinfection.
- ♣ **Collector pipe:** A perforated or slotted pipe that collects spring water.
- ♣ **Collection system:** A system of gravel, collector pipe, and a trench or spring box and/or cut-off wall used to contain the spring.
- ♣ **Cut-off ditch:** An excavated trench extending below the water-bearing formation and into an impervious layer. It is used in place of a spring box.
- ♣ **Cut-off wall:** A well-tamped impervious wing shaped wall of clay, concrete, or other material that ensures the spring flow enters the collection system.
- ♣ **Diversion ditch:** A ditch above the spring box that diverts the surface flow around the spring development.
- ♣ **Overflow:** Plumbing that prevents excess spring water from undercutting the spring box.
- ♣ **Vent:** A screened opening that prevents a vacuum in the spring box.

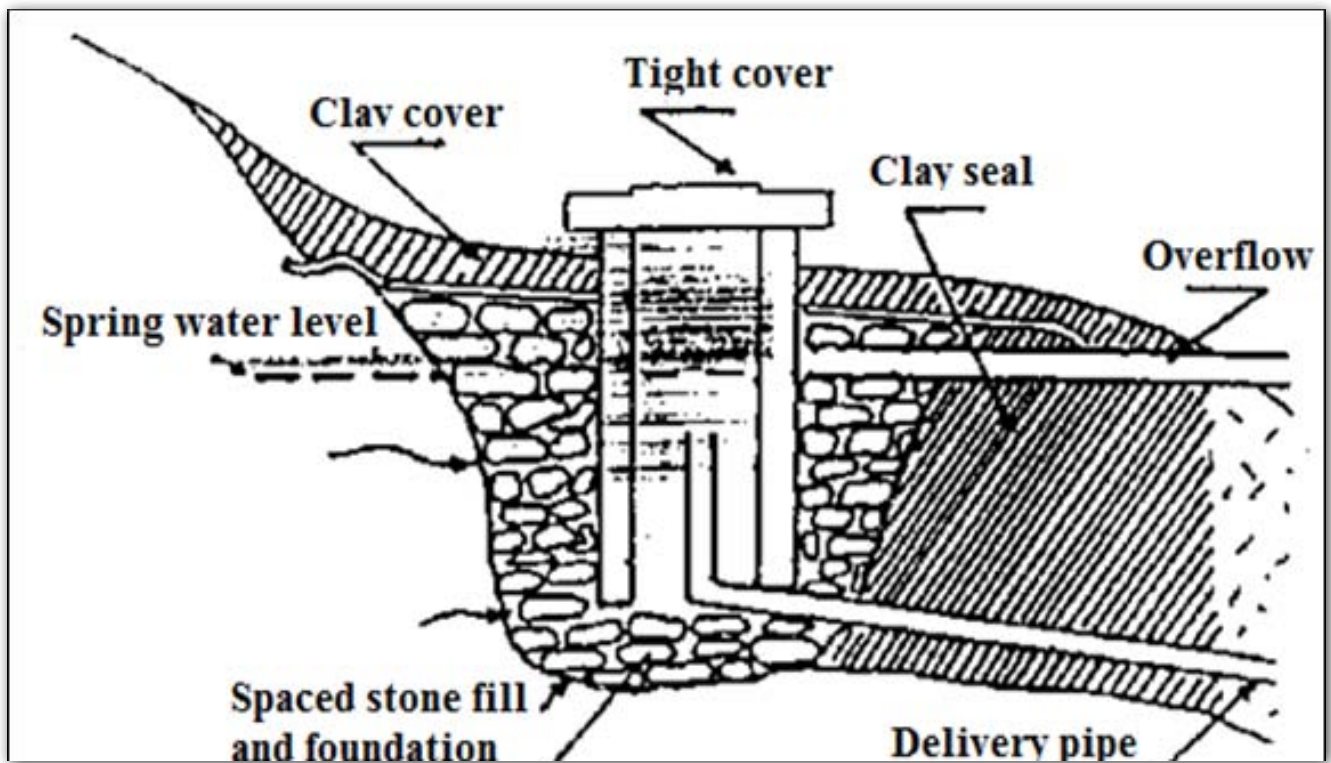

Fig 16.7: Spring box construction with tight cover

16.4 Benefits of Spring Development Structures

The obvious benefits of spring development structures include increased flow and reduced possibility of spring water contamination. However, there are other benefits that are less easily recognized. First of all, the cost associated with constructing a spring box is minimal, and the system is basically maintenance free, requiring only infrequent disinfections and sediment removal. Secondly, spring box technology is very simple and can be easily modified to fit just about any situation.

Although protective structures, such as spring boxes, do not necessarily improve accessibility of the source, they can be easily adapted to work in conjunction with other technologies such as gravity-fed distribution systems. Small springs can be developed at low cost to augment an existing water supply or to provide a source of water should the main water supply experience seasonal fluctuations.

16.5 Basic Design Features

Although there are many different designs for spring boxes, they all share common features. Primarily, a spring box is a watertight collection box constructed of concrete, clay, or brick with one permeable side. The idea behind the spring box is to isolate spring water from surface contaminants such as rainwater or surface runoff. All spring boxes should be designed with a heavy, removable cover in order to prevent contamination from rainwater while providing access for disinfection and maintenance (see Fig 16.7).

Spring box design should include an overflow pipe that is screened for mosquito and small animal control. It is also important to provide some measures of erosion prevention at the overflow pipe.

Approximately 8 meters upslope from the spring box, one needs to provide a diversion ditch capable of diverting surface runoff away from the spring box (see Fig 16.8), and animal fence should be constructed with a radius of at least 8 meters around the spring box. This protects the water source from livestock and wildlife contamination, as well as from soil compaction that could lead to reduced flow yields.

Some sources argue that by removing vegetation from the area surrounding the spring, flow may increase due to reduced water use by vegetation. Others maintain that shallow rooted grasses should be allowed to grow in the area due to their capacity for utilizing surface water before it is able to infiltrate and contaminate spring water. In either case, deep-rooted trees and plants should be avoided as their root systems could damage protective structures and reduce spring flow.

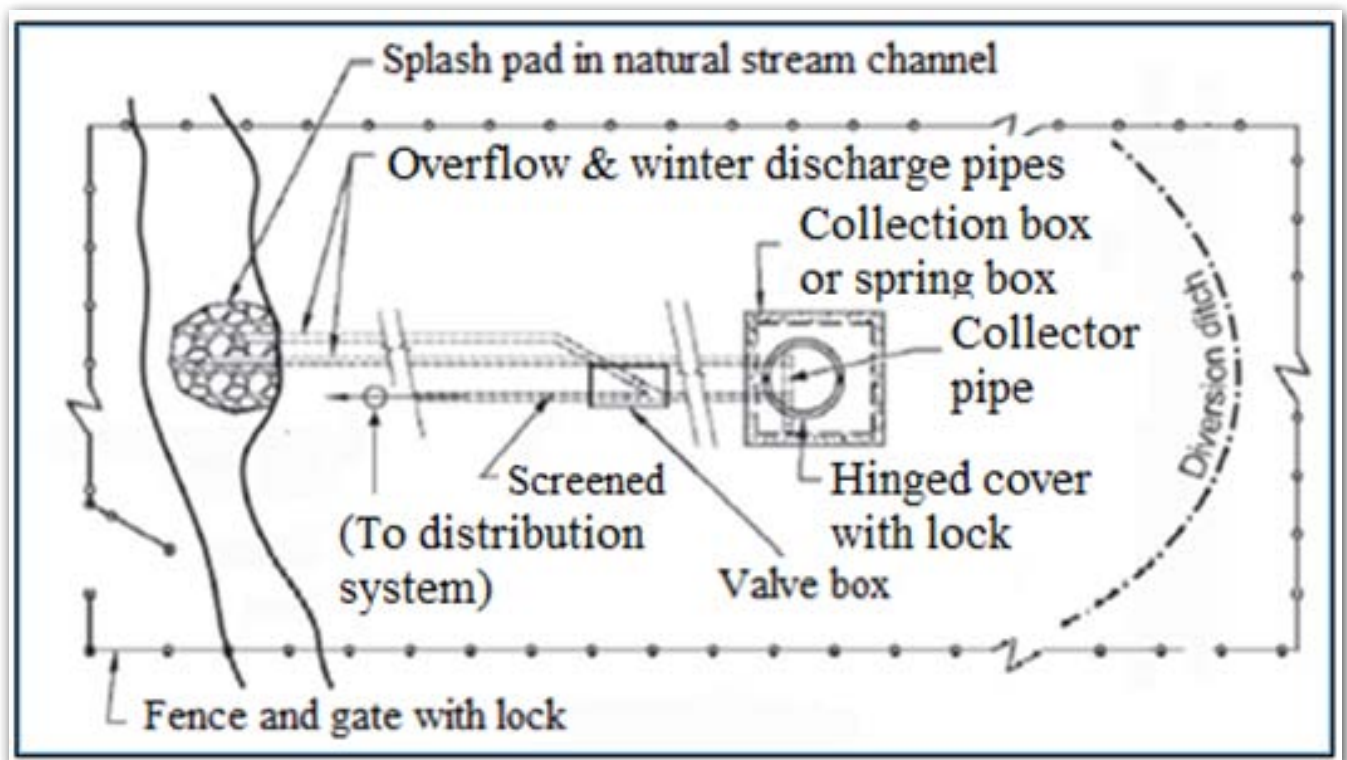

Fig 16.8: Typical spring, plan view (not to scale)

There are two basic spring box designs that could be modified to meet local conditions and requirements. The first is a spring box with a single permeable side for hillside collection, and the second design has a pervious bottom for collecting water flowing from a single opening on level ground (see Fig 16.9).

The spring box with an open bottom is typically simpler and cheaper to construct because less digging and fewer materials are required.

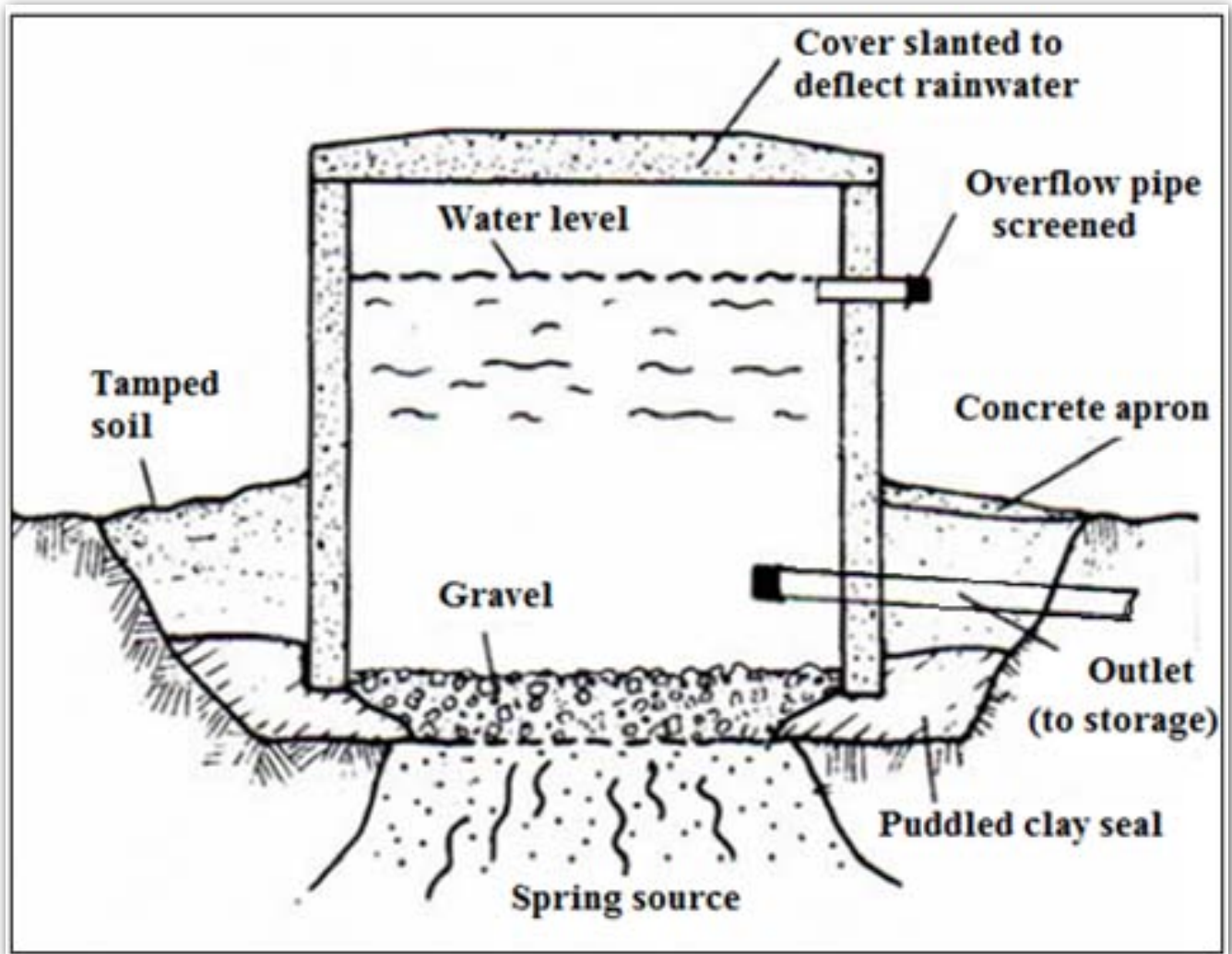

Fig 16.9: Spring box with permeable bottom for collecting spring water from an open level ground

16.6 Designing the Structure

Because each spring site is unique and every community has individual water supply needs, there is not a particular spring box design that will fit all circumstances. It is up to the project manager and the community to decide what will work best depending on local conditions. For instance, if the spring is located at a higher elevation than the distribution area and the distance is not too great, it may be preferable to design a spring box that is large enough to also act as a storage structure large enough to supply the entire community, thereby eliminating the need to construct additional water storage tanks (see Fig 16.10). It is also possible to design a spring box with a built-in sedimentation tank if the source has high sediment loads.

The design chosen for any particular spring development project will depend on local conditions, spring yield, available materials and community knowledge and requirements. The goal of the design process is to generate a dimensional plan of the spring box (see Fig 16.10) and a map of the area, including the location of the spring, the houses in the community, distance from the spring to the community and elevation change as well as prominent features and landmarks.

Another useful resource to produce during the design process is a list of all labour, materials, and construction tools needed, as well as those that are available on site. Such a list will help ensure that all necessary tools and materials are available on site in order to avoid delays and setbacks.

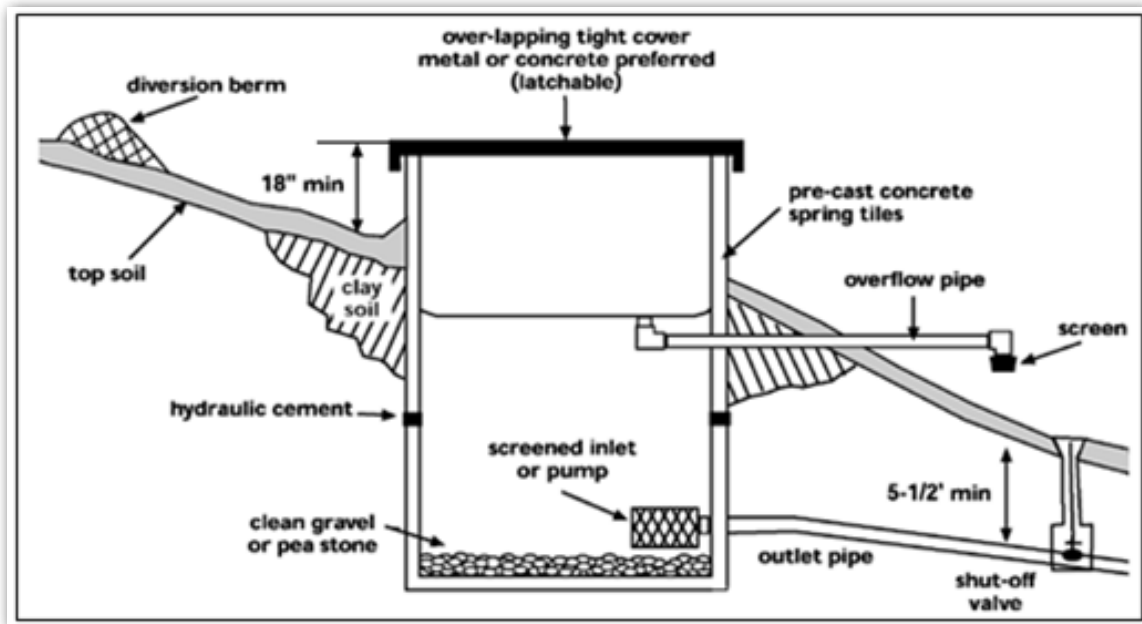

Fig 16.10: Typical spring construction with over-lapping tight cover

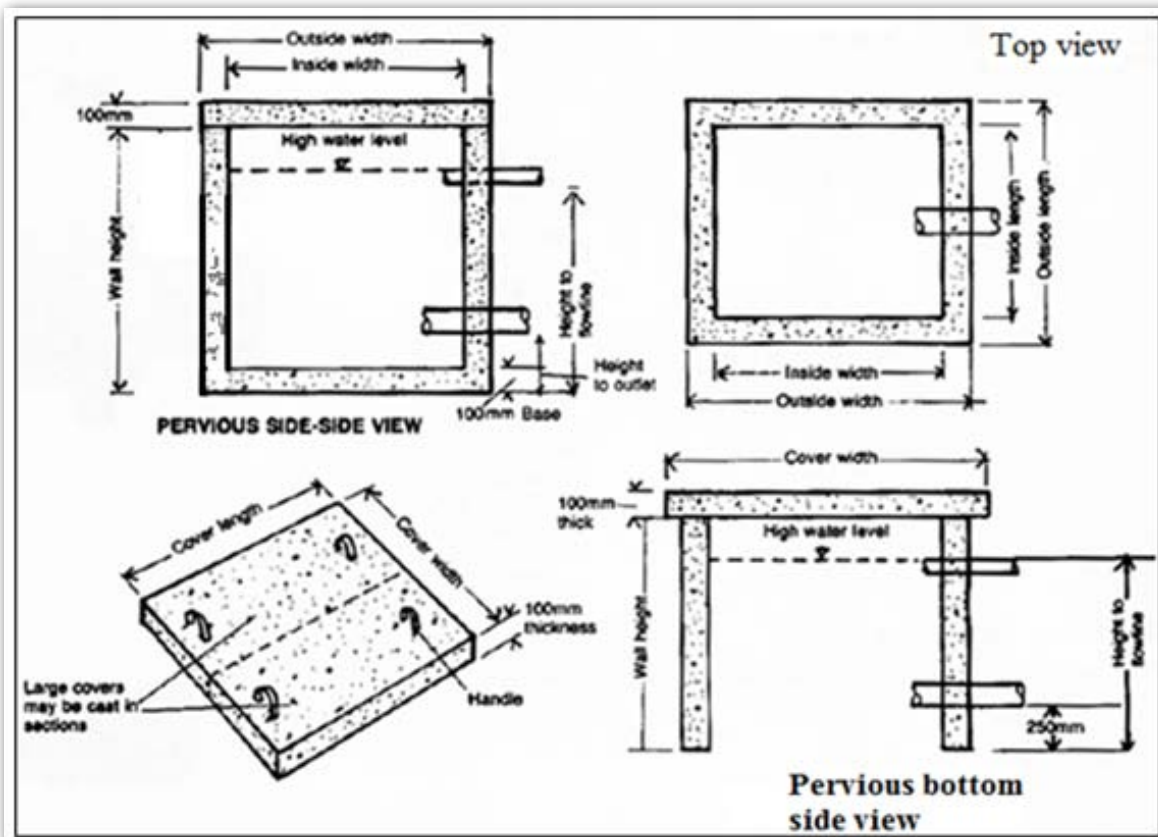

Fig 16.11: Dimensional plans of pervious side spring box & pervious bottom spring box

16.7 Selection of Site for Spring Construction

- ♣ A point source, where the water emerges from a single location, is the ideal situation.
- ♣ It is important to collect the spring water at its point source, not down gradient where surface contamination is likely. The source of the spring is usually at the uphill edge of the saturated area.
- ♣ The degree of slope is important. Generally steeper slopes are more desirable, and getting depth of cover is quicker for digging into a steep slope.
- ♣ Avoid spring sites that are located in depressed and concaved areas where surface water drainage is toward the spring.
- ♣ Avoid spring sites that are located down gradient from bodies of surface water like ponds, lakes, creeks, irrigation ditches, etc.
- ♣ Avoid spring sites that are located downhill from sources of pollution such as pits of toilets, sewage disposal systems, animal enclosures, fuel storage tanks, etc.
- ♣ If possible, avoid spring sites that are covered by growths of deep rooted trees, bushes, etc., because greater maintenance is required to keep the tree roots out. The decaying and dead root systems provide channels underground which may allow surface water to pollute the spring water.
- ♣ Ensure that the spring site is located on land that is owned by the user, or ensure that the user has authorized and documented rights to use the spring. Water rights, maintenance agreements, and recording on the deed can be written to address use of the adjacent watershed to protect the spring site for the user. Authorized ownership rights will guarantee the right to use the water from the spring.
- ♣ If the spring cannot supply the system by gravity flow, consider the alternative of drilling a well.
- ♣ Evaluate and avoid a site with evidence of burrowing rodents or plan to install underground wire mesh to prevent burrowing of rodents into the spring collector.
- ♣ Evaluate the site for accessibility of construction equipment, such as a backhoe for delivering gravel and other construction materials.
- ♣ Springs that demonstrate wide seasonal fluctuations in flow are suspected as being under the influence of surface water.
- ♣ A rock-filled collection bed or trench in a flat swampy meadow, beside a stream, or in the stream bed itself, is not a spring source which is producing ground water. Rather, it is a collector of subsurface water, or shallow ground water, which is under the influence of surface water and is therefore subject to the treatment requirements of surface water.

16.8 Preparing Site for Spring Construction

Once construction materials and labour are accounted for, the spring needs to be located and the site prepared (see Fig 16.12). The site should be fenced off to protect it from animals, and a diversion ditch needs to be dug approximately 8 meters upslope from the site to divert surface runoff water away from the spring. Next, dig out the spring until the flow is concentrated from a single source point (spring eye). If the spring is located in a hillside, it may be necessary to dig into the hillside far enough to locate the spring eye. See if flow from major openings increases, or if flow from minor openings decreases or stops.

These are signs that the flow is becoming concentrated from a single eye or source point. Remember that the objective is to collect as much water as possible from the spring and that it is generally easier to collect from a single opening than from many separated openings.

If a single flow source cannot be located because of numerous separated openings, it will probably be necessary to construct a seep collection system rather than a spring box. Depending on the terrain of the site, it may be necessary to dig a temporary diversion ditch to drain spring water from the excavation site.

Once a single spring eye is located, dig down until you reach an impervious soil layer. This will make a good, waterproof foundation for the spring box. Before installing the spring box, pile stones and gravels against the spring. This will provide some capacity for sedimentation and will prevent erosion from around the spring eye, which will also support the impervious section of the back wall of a pervious-side spring box (see Fig 16.14). If the spring is flowing from a single opening on level ground (pervious-bottom spring box), dig a basin around the spring eye until an impervious layer is reached. Line this basin with rocks and gravel, making sure to cover the spring eye so that water flows through the gravel before entering the spring box (see Fig 16.9)

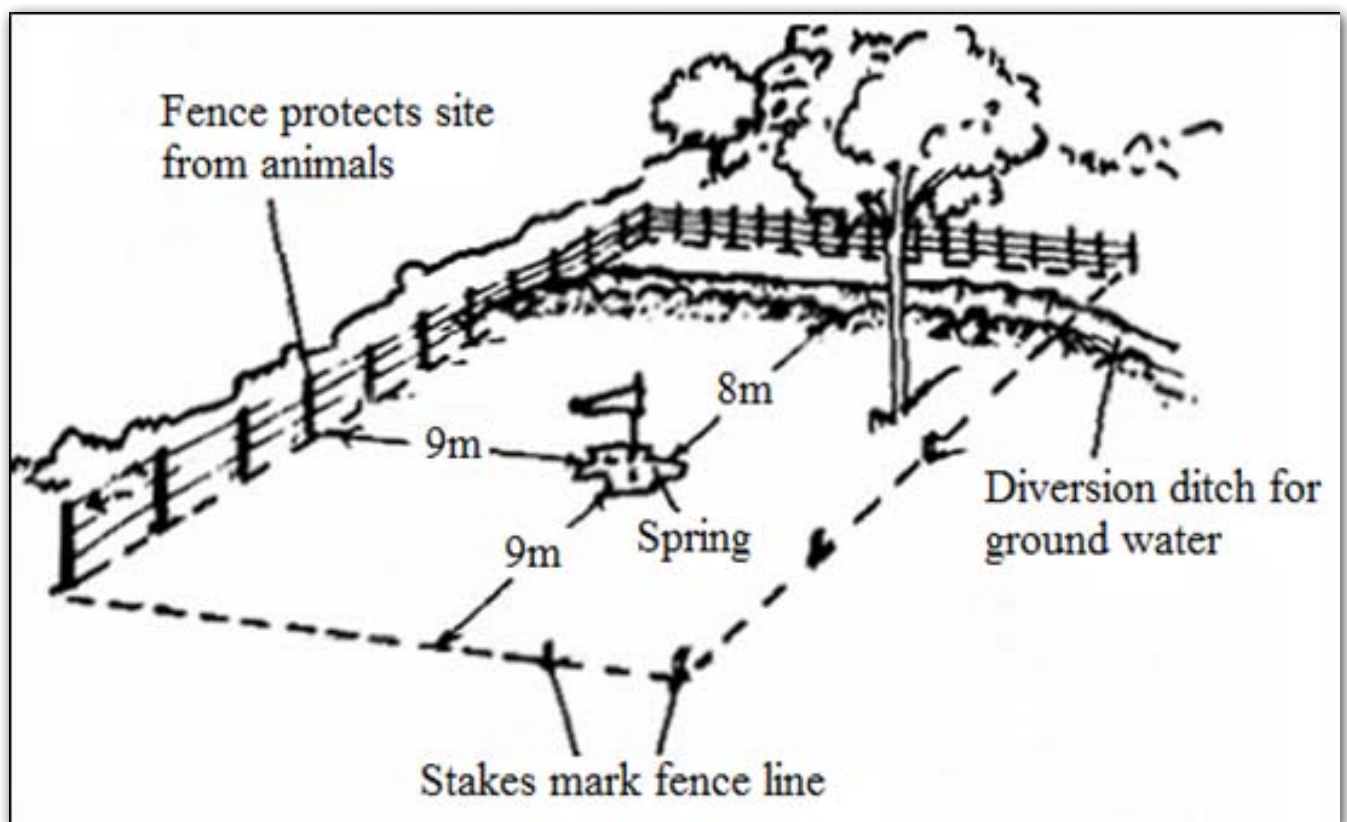

Fig 16.12: Preparation of spring box site

16.9 Spring Construction

- * Determine the general approach to the development of the spring site and the best way to collect the water:
 - i. Use a horizontal trench excavation parallel to the contours of the hill, or
 - ii. Use a trench excavation parallel to the slope of the hill.
- * Carefully excavate and remove the soil overburden to locate and isolate the exact point source of the spring water, if possible, and to expose the point where the water emerges from the “parent material or bedrock.”

- * At this time, make measurements of the spring flow to determine if the quantity is adequate to supply the needs of the system.
- * Dig as deep as reasonably possible to get as close to the origin of the spring where it issues from the “parent material/bedrock”. The reason for this is to maximize the solid backfill cover over the spring and minimize the possibility of contamination by surface water and the need to import backfill material.
- * Plan to provide a minimum cover of 5 feet (1.52 m) of acceptable backfill material above the collection bed.
- * Place the drain rock in the trench excavation to create a collection bed. Place the rock all around the perforated collection pipe for a minimum of 10 inches (25.4 cm) in all directions. These dimensions assume a 4 inch (10.16 cm) diameter collector pipe in a 24 inch (60.96 cm) wide trench.
- * Use PVC plastic pipe, concrete pipe, or vitrified clay tile pipe to construct the collector pipe. The types of pipe are generally more durable under these circumstances than metal pipe or asbestos cement pipe.
- * Place a polyethylene membrane on the top of the drain rock to prevent migration of backfill material into the rock collection bed. Seal and anchor the edges of the membrane by keying it into undisturbed soil in the walls of the trench.
- * Backfill the trench with compacted backfill (suitable impervious soil). This backfill soil should have a significant content of clay and silt (approximately 20 percent or more) to ensure that surface water cannot percolate through it easily.
- * Place a second polyethylene or equivalent membrane at the top of the trench at a depth of 12 to 18 inches (30.48 cm to 45.72 cm) below the final ground surface.
- * Provide a watertight seal at the point where the discharge pipe penetrates the polyethylene membrane using clamps or other means.
- * Particular care must be taken to provide a waterproof barrier dam of compacted impervious soil or other material around the discharge pipe to prevent seepage out of the collector bed along the discharge pipe. It is important to note that the discharge pipe should remain the size of the collection pipe in order to allow full flow out of the spring and prevent water back pressure from high flows leading to damage to collection system.
- * Maximize the backfill soil cover above the collection bed to a minimum of 5 feet (1.52 m) to prevent surface water from percolating into the spring and comingling with the spring water. The backfill should be graded into a mound shape that will shed surface water away from the spring area. The mounded area should be seeded with native grasses or other small vegetation which will discourage erosion and maintain the shape of the mound.
- * Construct a surface water diversion ditch approximately 12 inches (30.48 cm) deep on the uphill side of the mounded area.
- * During all phases of spring construction, take reasonable care to avoid contaminating the spring excavation area. Topsoil and organic matter contain bacteria which may contaminate the excavation. Also keep the spring construction materials (drain rock, pipe, membranes, etc.) as clean as possible.
- * Provide a suitable sample tap on the spring discharge pipe to allow collection of samples of the spring water for water quality analyses.
- * If livestock graze in the area, consider fencing the spring area from at least 100 feet (30.48 m) uphill and between 25 feet (7.62 m) and 100 feet (30.48 m) downhill from the source to prevent these animals from trespassing or intruding. Animal wastes are a pollution threat to the spring and the presence of many animals may encourage erosion.

- * Remove all trees, shrubs and other woody growth in the area to prevent intrusion of root growth into the collector. A clear area of 100 feet (30.48 m) radius from the spring may be necessary to prevent roots being a problem. These plants can also “steal” a significant portion of the flow produced by the spring, and their roots provide a channel for surface water and bacteria to enter the spring and pollute it.
- * Take care to protect the spring piping from freeze damage by providing adequate depth of burial, insulation and for maintaining continuous flow through the piping.
- * Provide an adequately constructed, raised, screened U-bend air vent on the discharge pipe as it exits the spring collector. This vent or opening will prevent formation of air bubbles in the discharge pipe between the spring and the storage tank, and it will prevent the creation of vacuum conditions in the spring collector by flow draining down the discharge pipe to the tank.
- * The discharge piping from a spring collector must be constructed so that the flow from the spring is always draining out of the collector and can never be turned off. If a valve on the discharge pipe is closed and water is backed up into the collector, the accumulating water pressure may seriously damage the collector. It may also cause a decrease in the spring’s production capacity because the spring flow has been diverted underground to another location away from the collector.
- * Provide a lock for the valves (if any) on the spring discharge pipe to prevent unauthorized tampering or damage.

16.10 Constructing the Spring Box

Although concrete construction requires that the concrete remain moist for at least seven days, spring box construction should be done at the peak of the dry season. This is to ensure that only the most reliable springs are protected. Since the strength of the concrete will increase with curing time, construction of the spring box should start as soon as the proper design for the particular spring is chosen, preferably on the first day of work. However, it is often necessary to excavate the spring before construction is initiated in order to determine the type of spring to be protected and the proper design to implement.

The first step in spring box construction is to ensure that all required materials and tools are available on site. This will help avoid construction delays. The next step is to build forms. The dimension of the form will depend on the dimension of the spring box, but a good rule of thumb is that the outside dimension of the form should be 10 cm larger than the dimension of the spring. When constructing a spring box for a spring flowing from a single source on level ground, a form with an open bottom should be built (see Fig 16.13). If a pervious-side spring box is to be constructed, a form needs to be built for a box with an impervious bottom and one permeable side. In order to build a form for a box with a bottom, set the inside form 10 cm above the bottom for the floor. This can be done by nailing the inside form to the outside form so that it is left hanging 10 cm above the floor (see Fig 16.10). Make holes in the forms to fit the diameter of the overflow and outflow pipes, and place small pieces of pipe in them to ensure that properly sized holes are left in the spring box when the concrete sets.

Make sure temporary braces are installed on the outside of the forms and that wire bracing is used between the inside and outside forms. If the forms are not properly braced, the weight of the cement will cause the forms to separate. To brace with wire, drill small holes in the forms and place wire through them to tie them together. Tighten the braces by twisting the wire with a strong stick, thus pulling the forms together (see Fig 16.10).

Next, set the forms in place, either in the permanent site or nearby, depending on the size of the spring box. If the spring box is so large that installation will be difficult after the concrete has been placed and cured, the form should be in its permanent site prior to placing the concrete. Make sure that your temporary diversion ditch is functioning properly while the concrete cures. Prior to placing cement in the forms, oil the inner sides with old motor oil so that the concrete does not stick to them. Keep in mind that although the spring box walls do not require major reinforcement, minor reinforcement around the perimeter of the box will prevent cracking of the cement. It is best to refer to concrete construction guides to determine the proper level of reinforcement for a particular spring box. In addition, the cover will require significant reinforcement, and handles will facilitate cleaning and inspection.

The spring cover should be sloped or concave so that water does not puddle on top of the cover. Concrete should be mixed in a proportion of one part cement, two parts sand, and three parts gravel (1:2:3). Only add enough water to make a thick paste, as too much water leads to weak cement.

Finally, place the concrete into the forms, tamping (compressing) as you go to ensure that there are no residual air pockets. This can be done by "vibrating the forms," which can be accomplished by pounding the outside form with a rock or hammer. Smooth out all concrete surfaces to ensure that the cover fits well, and cover with wet canvas, burlap or straw to prevent the concrete from losing moisture. This protective covering needs to be kept wet throughout the curing process, at least seven days, although longer curing will result in a stronger structure.

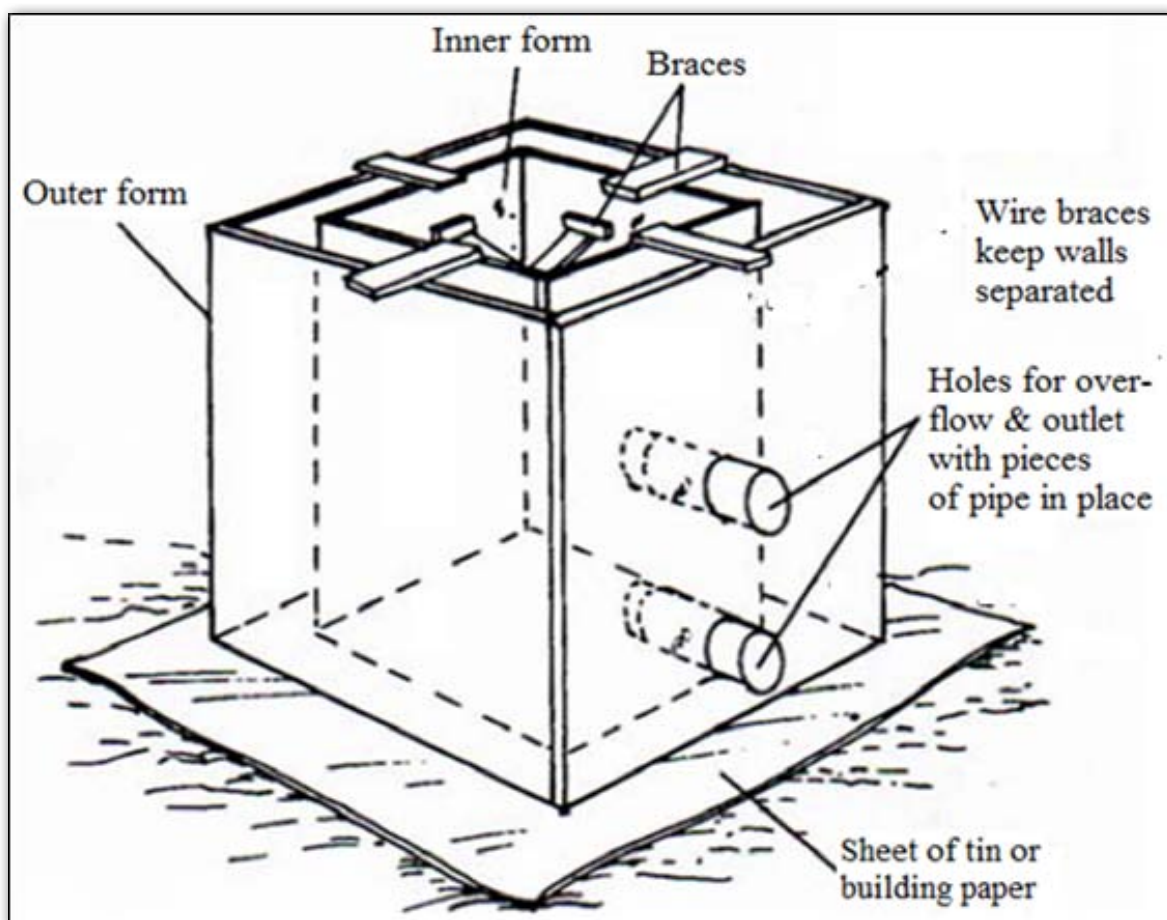

Fig 16.13: Form for a permeable-bottom spring box.

16.11 Installation of Spring Box

To minimize the possibility of contamination, it is important that the spring box be installed on a solid, impermeable base and that a seal is created between the ground and the spring box so that outside water is unable to infiltrate the box. Place the box so that the permeable section of the spring box collects the flow of the spring.

When installing a hillside collection box, make sure that gravel and stones are piled at the back of the box to provide structural support for the structure while allowing water to enter the box (see figure 16.14). Next, create a seal with concrete or puddled clay (a mixture of clay and water) where the spring box comes into contact with the ground. This will ensure that water does not seep in under the box. For hillside spring boxes, backfill the area where the spring enters the box with gravel to the height where the permeable wall ends and the concrete wall begins. Place layers of puddled clay or concrete over the gravel backfill and sloping away from the spring box to divert surface water away from the water source, and then backfill with firmly tamped soil. If puddled clay or concrete is unavailable, soil alone may be used, although it should be at least 2 meters deep to prevent contaminated surface water from reaching the water source. For a level-ground spring box, puddled clay or cement should be placed around the spring box, sloping away from the water source to prevent infiltration.

Remove the pipe pieces used to form the pipe holes in the spring box and install the outflow and overflow pipes. Seal around the pipes on both sides of the wall to prevent leaks, and secure screening over the pipe openings. Make sure the screen size is small enough to prevent mosquito infestation, yet strong enough to deter small animals, and of a material durable enough to last a long time (for example, plastic screening works best).

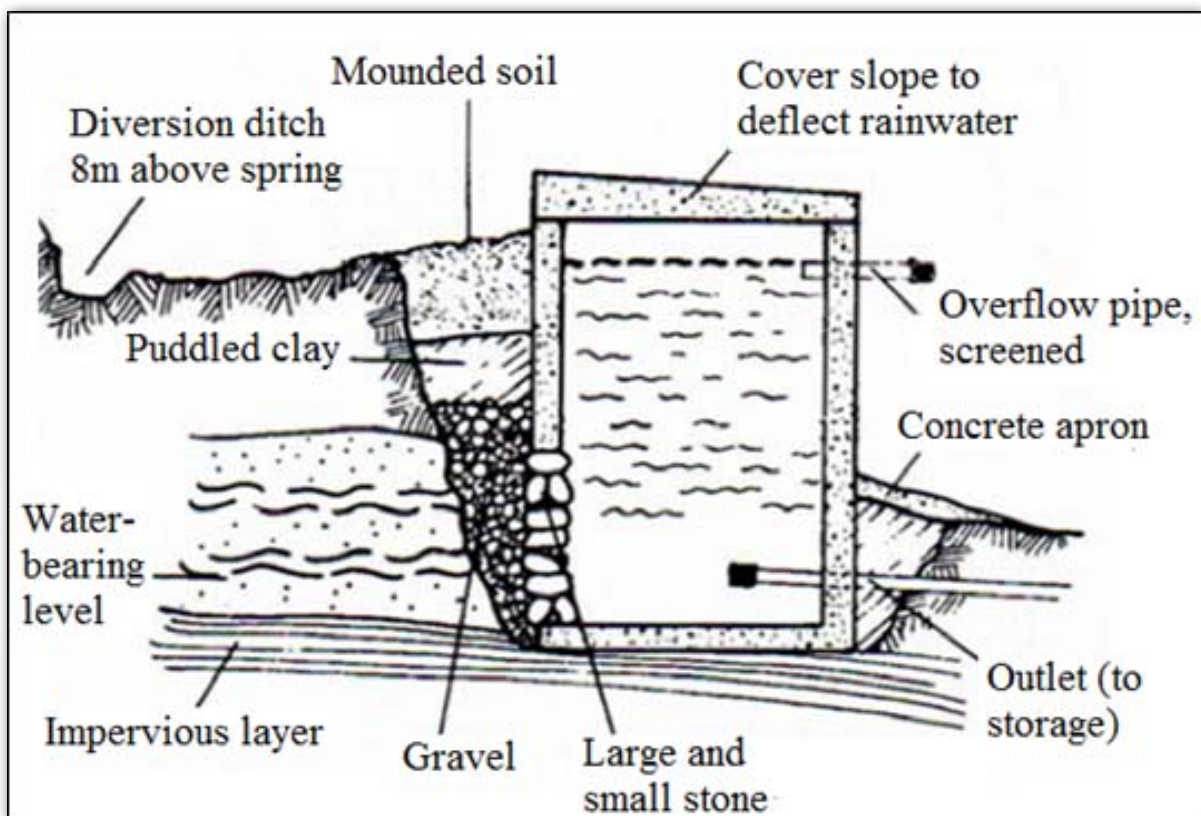

Fig 16.14: Spring box with single pervious side for hillside collection

Before completely backfilling the spring box, disinfect the inside of the box and the cover with chlorine solution and close the box. Remember that all backfill should slope away from the spring box to maximize runoff away from the box.

16.12 Alternatives to Spring Boxes

Spring boxes are not the only method of protecting spring water sources. There are alternative structures that may suit the needs of the community better than a spring box. For example, if the distance from the spring eye to the primary distribution point isn't great, a stone-filled trench and headwall may be a preferable method of spring water protection. The design is much simpler, which may facilitate the dissemination of this technology from one community to the next, as the design is easier for local masons to copy. They are also quicker to construct and require less cement or local materials than a spring box, making them cheaper to build. The basic design of a stone-filled trench and headwall is to dig a trench from the distribution point to the spring eye.

The trench should have a fairly impervious bottom to minimize water loss through infiltration. Two options exist for transporting water from the eye to the distribution point. The first is to simply fill the trench with clean stones and a layer of puddled clay approximately 100 mm thick; over the stones in order to prevent surface water from infiltrating and contaminating the source. The second option is to pile clean stones over the eye, protect the source with a layer of puddled clay, and use a plastic pipe to convey water from the source to the distribution point. This method has several advantages over the stone-filled trench. First, if the topography allows, the pipe can be situated so that the outlet is above ground, eliminating the need to construct a large headwall. If this method is used, it is necessary to protect the above ground portion of the plastic pipe with a short length of steel pipe. With either method, a concrete headwall will need to be constructed at the outlet with a concrete apron below the outlet pipe to provide easy access and to prevent erosion.

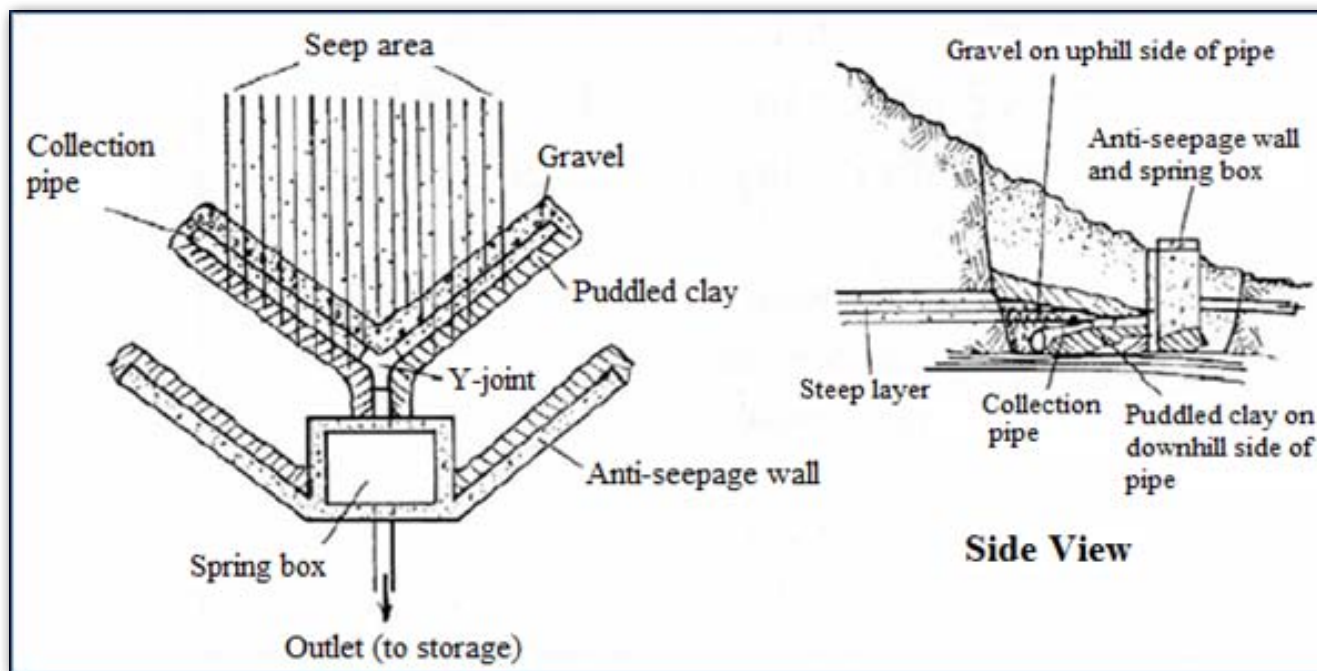

Fig 16.15: Seeps and spring intake with collection pipes

A second alternative to a spring box is the development of a horizontal well (see Fig 16.16). These are particularly useful where the water table is steeply sloped. In a horizontal well, a pipe with a screened or perforated driving point is driven into an aquifer horizontally at a higher elevation than the spring's natural discharge. Often, a headwall will need to be constructed in order to adequately seal the space outside the pipe. The only requirement of horizontal wells is that the water table be steeply sloped. Flat water tables typically will not be under enough pressure to provide adequate flow.

If a single spring eye cannot be located, a seep collection system is a third alternative to a spring box (see Fig 16.15). In a seep collection system, perforated collection pipes are laid in a "Y" shape perpendicular to the seep flow in order to collect and concentrate water, which is then diverted to a spring box or to a storage tank (see Fig 16.15). Designing and constructing a seep collection system is much more difficult and typically more costly than other methods.

In addition, collection pipes often clog with soil and rocks, making water collection less efficient and requiring more frequent and intensive maintenance.

16.13 Operation and Maintenance

Most spring contamination results from poor spring development, construction, or from direct flow of surface water into shallow groundwater feeding the spring. Spring water should be tested before and after heavy rains each year for bacteria, pH, turbidity, and conductivity to determine if surface-water contamination is a problem.

If properly installed, spring boxes require very little maintenance. However, it is recommended that the water quality be checked before being put into use, and also on a yearly basis or as needed. It is also a good idea to check that the uphill diversion ditch is adequately diverting surface runoff away from the spring box and is not eroding. One maintenance item that is frequently overlooked is to ensure that the animal fence is in good repair.

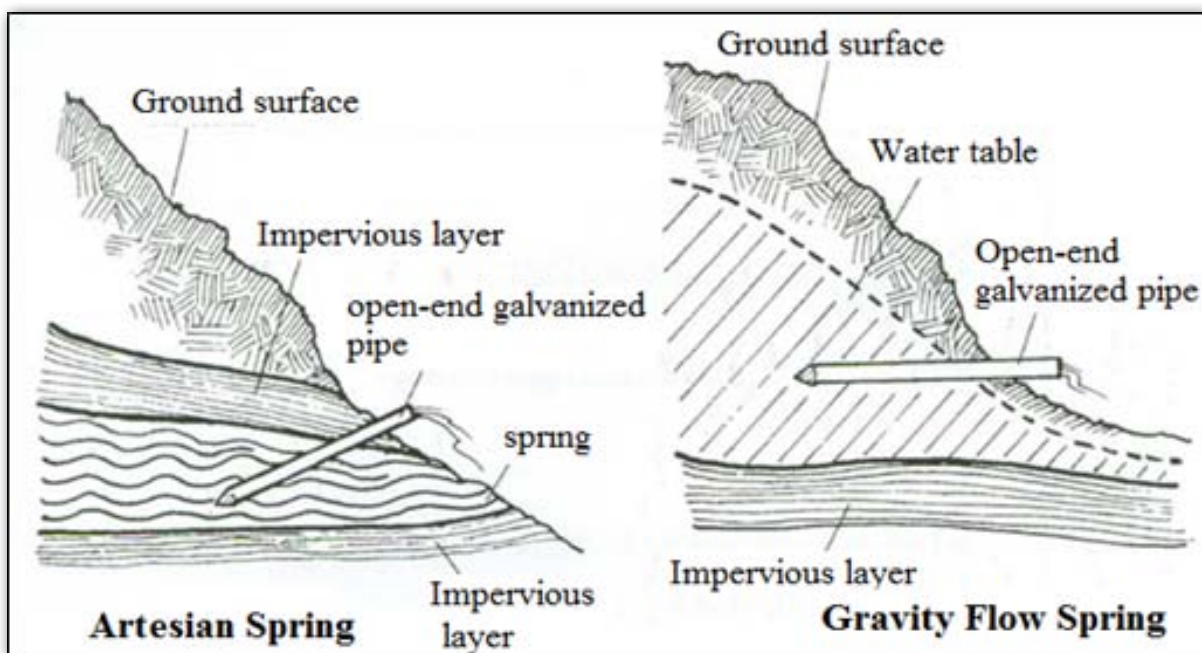

Fig 16.16: Spring construction with horizontal well placement

Although some grazing area may be lost, the loss in grazing area is preferable to a contaminated water source or compacted soil that could lead to decreased flow rates. For hillside collection boxes, it is important to check that the uphill wall is not eroding and is maintaining structural integrity. The cover should be checked frequently to ensure that it is in place and appears to be watertight.

Make sure that water is not seeping out from the sides or from underneath the spring box, and check that the screening is in place on the overflow pipe. In general, consider the following activities in operation and maintenance of a spring: Cut all woody plant growth every year to control root damage to the water source and collection piping.

- * Remove all dead vegetation within eight meters of the spring.
- * Remove woody brush and shrubs to prevent roots from intruding into the collection area.
- * Grade the spring collection area to prevent standing surface water.
- * Check that the fencing is intact, repaired and the gate is locked.
- * Check that the spring box lid is locked. The lid should be a shoe-box design with 8 centimeter overhang.
- * Check that the spring overflow is armoured or non-breakable. Place a large rock in the overflow splash zone if it is missing.
- * Check that the vent is screened and in good repair.
- * Check the overflow screen to ensure that it is intact. Replace damaged screen.
- * Keep open all drains from the valve boxes to prevent ponding water.
- * Maintain the surface water drainage ditch uphill from the spring.
- * Clean the diversion ditch of any winter debris. Check that the ditch is in good repair and directs surface water around the spring collection area.
- * Check for and repair any obvious damage to the water collection and storage system.
- * Clean debris out of the spring box and repair the seals.

Once a year, disinfect the system and remove sediment from the spring box. To do so, open the valve on the outlet pipe, allowing the spring box to drain. Remove any accumulated sediment from the box and wash the interior walls with a chlorine solution. It should be noted that chlorine and chlorine compounds might irritate eyes and skin. Proper protective equipment such as gloves, safety glasses, and protective clothing should be worn if available when dealing with chlorine.

The solution for washing the spring box should be mixed in a ratio of 10 litre water with 0.2 litre chlorine bleach. After washing the interior of the spring box, chlorine should be added directly to the water in the spring box in a ratio of 100 parts chlorine per million parts water, and allow it to sit for 24 hours. If it is not possible to allow the chlorine to sit for 24 hours, two consecutive applications twelve hours apart should provide for adequate disinfection. If possible, water samples should be analyzed periodically for contamination.

Design and Construction of Community Roads

17.1 Description

Development of natural and human resources is not possible without improvement in communication, transportation, health care facilities, education system, a working mass information media and institutional support, watershed development policy and informed administration. The infrastructure development, which is usually divided into physical and social infrastructures, is very important for all natural and human development and growth. The physical infrastructure development, which is the main interest of this manual, consists of physical facilities on a scale larger than that of individual farm and it includes roads, dams, irrigation schemes, structures and buildings, etc. Whereas, the social infrastructure covers educational institutions and organizations, credit and marketing services, tribal and communal laws, religious institutions, extension services, etc.

The stage of development of the physical infrastructure often provides an indication of the overall economic development of a country or given localities. The poor condition or complete absence of roads, storage facilities and marketing places necessitates crops and other farm inputs to be transported along feeder roads which are passable only part of the year. Moreover, the absence of storage facilities forces the farmers to sell their products immediately after harvesting when prices are low and not encouraging or attractive to them.

Under certain conditions, social considerations may exert a greater influence on human behavior than financial ones. In most traditional rural societies, farmers' decisions tend to be much affected by the attitudes of and the relationships within the local community to which they belong and by the experiences handed down from one generation to the next. Due to traditional and cultural reasons, members of the rural community are usually reluctant to do anything that would upset the community structure or cut across traditions. Therefore, as all agricultural land is characterized by lack of physical infrastructure facilities, access roads to communities is indispensable and is a basic service to communities.

For any type of roads, a topographic survey of the alignment, the testing of construction materials, and soil mechanical study is required. If a plot of land is not accessible, it becomes virtually impossible to use modern agricultural inputs such as fertilizer, disease control, resources management and mechanization of certain farming activities. In many cases, the harvested crops cannot readily be transported, increasing the risk of pests and harvest losses. The construction of proper access roads is, therefore, important in order to be able to implement agricultural land development and resource management. A well developed and maintained all weather rural road is then the first necessity, not only for immediate agricultural production, but also for operation and management of natural resources. Rural access roads serve as a multidimensional means by which rural communities get basic social services, agricultural inputs, and transport crops to and from agricultural areas, etc. The design of rural roads depends on the potential traffic, which may be limited (in some cases) to a few vehicles a day serving a few communities and villages. A rural road could possibly serve many vehicles a day where a feeder road connects many communities or a large area to a main road. However, a feeder road serving low traffic or a few vehicles a day is the main interest of this technical manual.

17.2 Basic Principles and Parameters in Design and Construction

The basic parameters in community or feeder road construction are (1) length of the road (length measurement); (2) area of the road and volume of the work; (3) depth of the ditch; and (4) plan and cross section of the road. Area is defined as length multiplied by width. In other words, it is the result of two measurements of length multiplied together. The general units for area measurement are cm^2 , m^2 , Ha, km^2 , etc.

$$\text{Area} = \text{Length} \times \text{Width}$$

Correspondingly, volume is defined as length multiplied by width and height. The general units to measure volume of the earth work are cubic centimeter (cm^3), cubic meter (m^3), etc.

$$\text{Volume} = \text{Length} \times \text{Width} \times \text{Height}$$

In most cases, the quality of feeder roads depends on the availability of construction materials, but these construction materials may not often be readily available. In such cases, one may be forced to use the material found along the road. For example, loamy soils lose their strength when they become wet, but if these soils are mixed with a material containing a substantial proportion of soil particles they can give a good all weather surface. Sandy soils, however, will give too loose a surface in the dry season, and mixing these soils with a clayish material will improve the road surface performance. The surface of the rural roads must be sufficiently cambered to discharge surface water quickly and safely and the drains along the road must be designed to evacuate water to lower lying areas very quickly without creating soil erosion and sediment deposition problems.

While designing and constructing the feeder road, proper drainage is very important in the low-lying areas. To avoid drainage and other design problems, a feeder road should be located on well drained areas. Surveys for unpaved all weather rural road usually involves selection of an alignment or alternate alignment; examining the alignments on the ground (giving special attention to geological and soil conditions, availability of construction materials and water crossing); and constructing following a hydrological study to determine the size and number of bridges and culverts required. Surveying and setting out procedures of a feeder road consists of methods of setting out of the road; horizontal alignment; cross section; and vertical alignment. The important points that one should bear in mind while setting out the feeder road are: (1) decide roughly where the road is to go (selection of the route); (2) set out the center line of the road (horizontal alignment); (3) set out the level of the road on the center line (vertical alignment); and (4) set out the width of the road and position of the drains from the center line (cross section).

The most important tools and equipment commonly used for setting out feeder roads include range rods to set out straight lines; profile boards or boring rods to find the correct level; a line level to find the correct level; a tape measure to set out a right angle triangle from the center line through two points (say from point A to point B); an abney level to measure vertical angles and setting out levels; and a string and wooden pegs, about 40 cm long to mark out alignment and road levels.

In order to be seen from a far distance, the top parts of pegs should be painted with a bright color. When considering the construction of a road, several horizontal alignments may be possible. A straight and direct alignment from one place to another is not always the best solution. When selecting the horizontal alignment, avoid knocking down buildings; taking too much valuable farm land; and crossing difficult terrain like steep sections, large trees, boulders or swampy areas.

In general, the center line of the road is set out as a series of straight lines connected by curves. Straight lengths are set out by making the points along the straight lines with the ranging rods which are called the intersection points. Along a straight line, mark the center line at 20 meters intervals by guiding a person with a ranging rod so that the road is in line with the two ranging rods at intersection points (Fig 17.1).

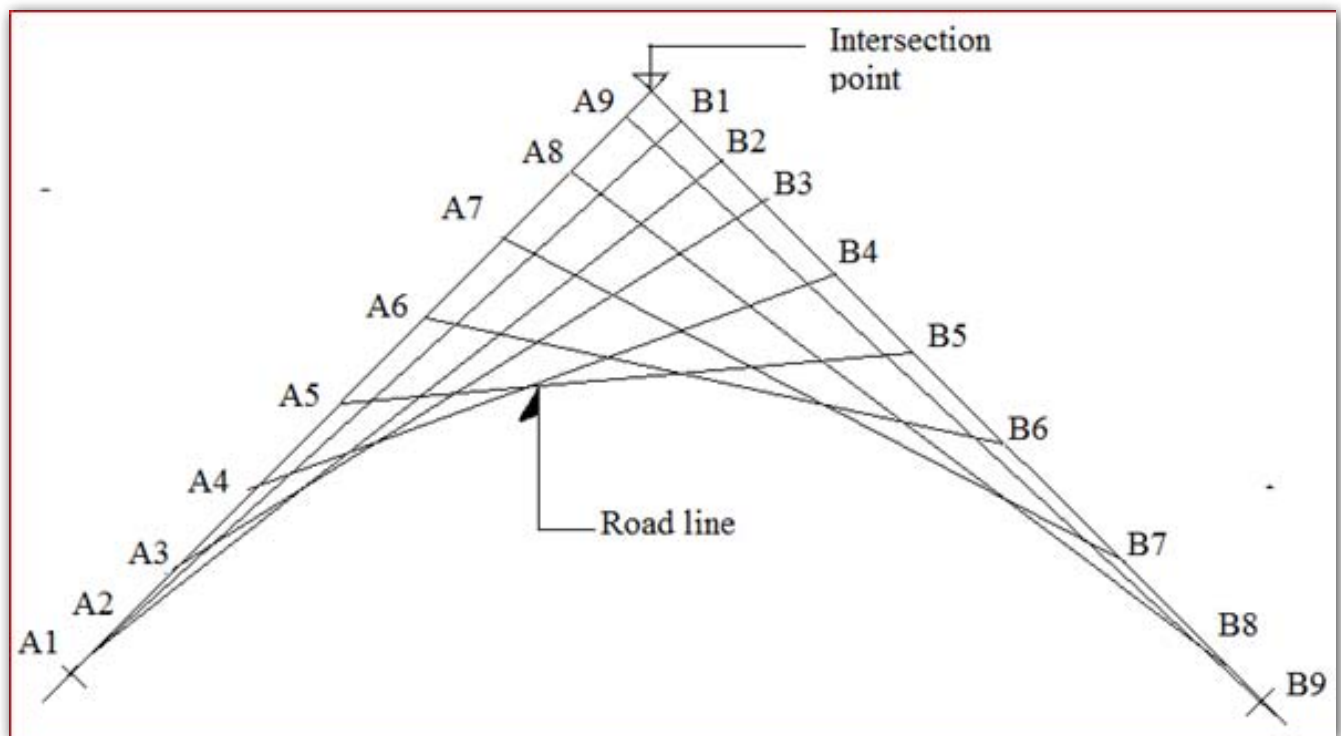

Fig 17.1 Section view for laying out sharp curves

In laying out roads in a sharp curve, curves are set out to join two straight sections. In order to design a road at very sharp curves use the following procedures: First, place a peg at the intersection point, which is where the center line of the straight sections cross. Now decide where to start the curve at one straight line and place a peg there (A1). Then measure the same distance from the intersection point on the other straight line and place another peg there (B1). These two points are called tangent points. Now divide the two lines into six or more equal parts, and place a peg at each point and mark them, as shown in Figure 17.1 above. Using strings, join the pegs (A9 to B9; A8 to B8; A7 to B7; A6 to B6; A5 to B5; A4 to B4; A3 to B3; A2 to B2; A1 to B1) as shown in the diagram. Put a yellow peg where the strings cross. Take out the string A9 – B9 and put it from A8 – B8; then take out the string A8 – B8 and put it from A7 – B7. Put in another yellow peg where the strings cross; and continue like this until you reach A1 – B1. You have now set out the curve with yellow pegs. By setting out sections, joined by curves, you have defined the alignment of the new road.

1. After completing the setting out of the center line and the levels of the road:
2. set out the cross section of the road. In this case, place the profile of boards in the middle of the side drains. These should be the correct distances from the center line and at right angle triangles to it. Use the 3-4-5 method to set out the right angles.
3. Transfer the level from the center line profile boards to the two side drain profile boards, using strings and line level.

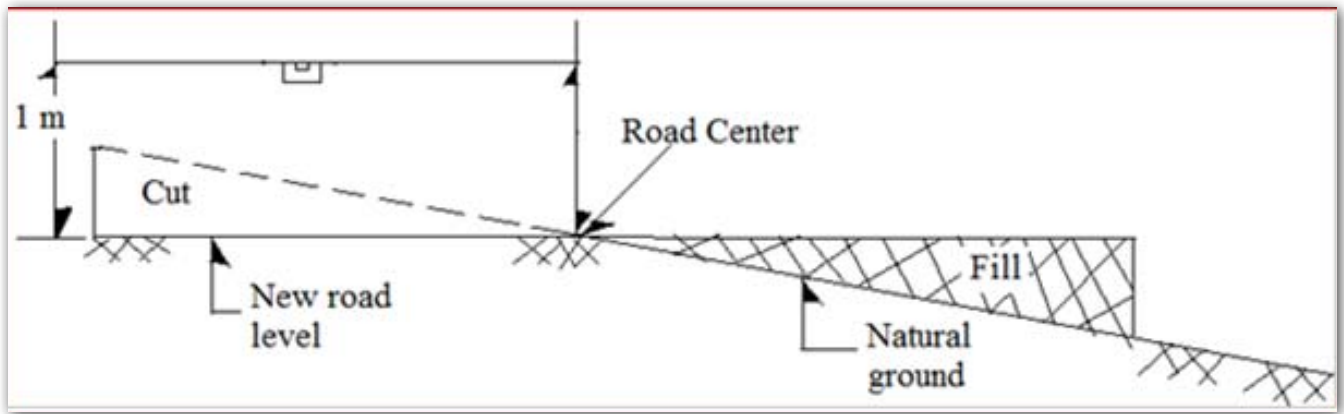

Fig 17.2 Cross section of cut and fill of earthworks

4. The level of the bottom of the side drains will be the level of the profile board minus the height of the profile board above the center line, usually 1 meter, minus the depth of the side drain, typically 25 cm below the center line.
5. Set out the edges of the road - the shoulders.
6. Excavate down to the level of the road as set out across the cross section. This means digging or filling until the profile boards are one meter above the level ground. At the lower side of the road, fill only up to the level of the shoulder.
7. Finally, excavate the side drains as necessary.

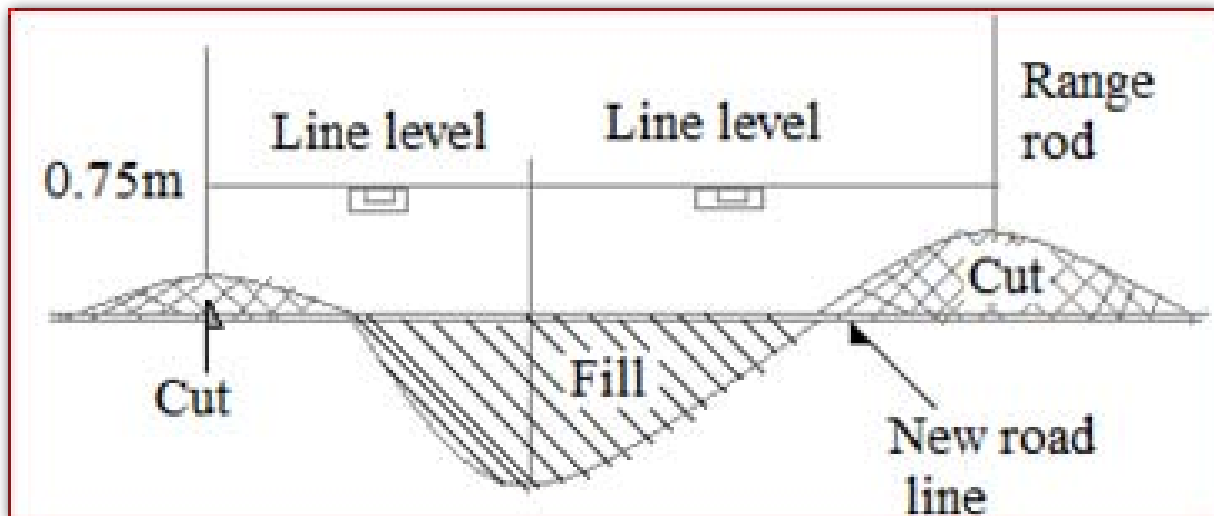

Fig 17.3 Alignment of a road on rugged terrain

The material from the side drains is used to form the camber of the road. In every flat terrain where drainage is difficult, it is better to raise the level of the road center line by 10 to 20 cm in order to keep the road drained.

Vertical alignment: Vertical alignment sets the level of the road. The method shown here sets out the level of the road first and then the side drains. In vertical alignment of a road, the following steps are followed:

1. Fix the profile boards at every ranging rod along the center line - along a distance of at least 100m. The profile should be one meter above the ground level.
2. Look along the profile boards.

3. Get someone to move the profile up or down so they are all in line. All the profiles are then all one meter above the line of the new road center line (before camber is made).
4. If this should mean too much excavation or filling, you can move the profiles up or down to make a smooth curve. Make sure that the first profile boards are placed correctly. All other levels you set out follow from this point. Alternatively, to set out over the crest of a hill, set out a new level by fixing a profile level (C) less than 100 m from A. So, sometimes you need to set the sight-line at intervals of less than 100 m. This is how vertical curves are formed, and how sharp crest or steep slopes are avoided.

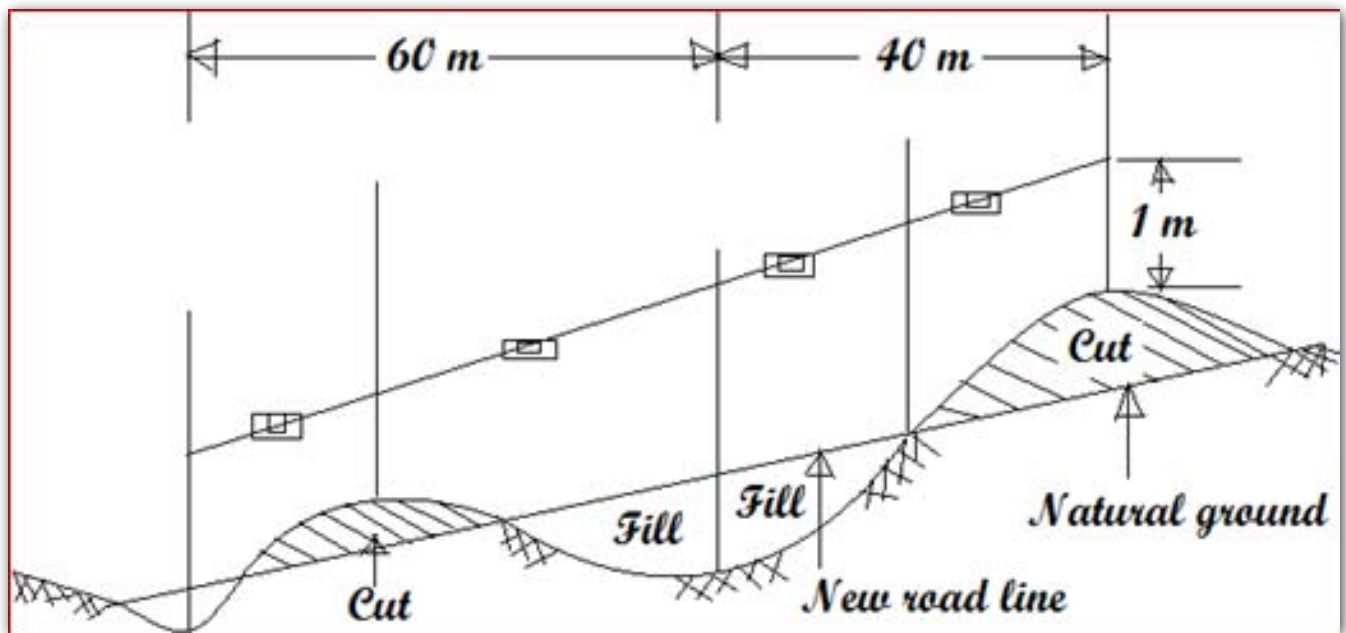

Fig 17.4 Lateral view of a road layout on a rugged terrain

17.3 Clearing of Ground for Community Road Alignment

Clearing is the removal of bushes, trees, boulders, and topsoil from the road alignment. Site clearing is usually the first operation to be done once the road alignment has been set out. The purpose of clearing is to make construction possible by clearing the path for the feeder road. Removing of stones and boulders is time consuming. There may also be a need to pay compensation to the owner because every tree belongs or may belong to someone.

So, before starting major clearing work, consider the option of changing the road alignment or route. To clear the area for the road alignment and construction:

- ♣ Set out the area to be cleared.
- ♣ Check the types of bushes and trees to be cleared.
- ♣ Decide on the tasks rate.
- ♣ Instruct workers who are to clear the road route.
- ♣ Ensure that workers have enough working spaces and tools.
- ♣ Now start the work.
- ♣ Throw bushes outside the cleared area, heap them in the center for burning later.

Bush clearing is cutting to the ground level and removing all the bushes, grasses and shrubs. This should be done within the road width itself plus usually 5 m on each side. Don't forget to allow for side drains and working spaces. The tools used for the clearing job are brush hooks to cut the dense bushes, and manual plant pullers to remove small plants. Before felling the trees make sure that it is absolutely necessary to cut them down. It is true that trees obstruct construction activities. Trees also prevent a road from drying out quickly after rains and so do affect the road strength (a dry road is stronger than a wet road). On the other hand, trees help prevent soil erosion, so they are very useful. If you leave a tree, do not damage it, or its roots. Once you decide to cut down a tree, use only experienced workers for the job and keep everyone else well away. Large trees are felled using their own height and weight. While felling large trees, follow the following steps:

- * If you are using a saw, insert wedge before saw jams.
- * Cut a felling sink in the direction you want the tree to fall.
- * Make a felling cut with a cross cut saw opposite and above the sink.
- * Continue saw cutting until the tree begins to fall, and then keep yourself and other people away.
- * After felling the tree, cut it into pieces and remove the cuts or branches from the road side.
- * Finally, remove the tree stumps and all its roots.

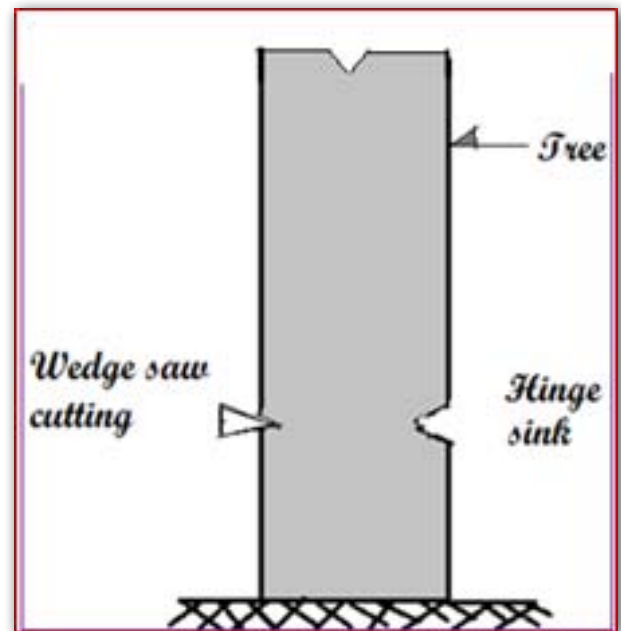

Fig 17.5 Tree cutting system

Similarly, removing boulders is time consuming and requires an experienced labour force. Consider whether, as an alternative to removing boulders, the level of road can be raised to cover them, but this can be expensive. If clearing the boulders is necessary, consider various methods, either separately or in combination. The basic steps of removing boulders are the following:

- ◆ Move the boulder outside the road way.
- ◆ Bury the boulder on the road side.
- ◆
- ◆ Crack or brake the boulders into pieces and remove the broken pieces from the area of the road.
- ◆ Blast large rocks and remove the pieces.

You may bury boulders which are more than 0.5 m³ or embed deep in the ground by digging a hole next to them. However, before attempting this method, estimate the size of the boulder in relation to the hole to bury it. Then dig the hole as close to the boulder as possible and tip it in with crowbars or jacks or a winch, if necessary.

Crack boulders into small pieces for removal if it is not possible to move or bury them. Heat the boulder or rock by starting fire over it and keeping it going for at least six hours, then cool the rock suddenly by pouring cold water over it, the heat makes the boulder expand, the cold makes it contract and crack so that the boulder can then be broken up with sledge hammers. This method may be fun to use but it is time consuming and expensive and use it only as a last resort.

Boulders can also be broken up with simple hand tools by trying to find cracks or weak lines. Blasting method is an efficient method, although dangerous and expensive, and beyond the mandate of the labour intensive feeder road construction. A large rock can be broken up quickly by drilling holes and then splitting the rock with sledge hammer and crowbars. Tools used for the job are crowbars, shovels, pickaxes, sledge hammers, winches, plugs and feathers, wedges, chisels and tongs, as well as safety items such as goggles and gloves.

17.4 Removal and Excavation of Top Soils for Community Road Construction

Topsoil is the soil near the surface in which plants grow. The main reasons that the top soils are removed are that they contain a lot of organic matter which decays, so it is not a strong layer for building the road. Secondly, top soils allow grasses and plants to grow through onto the roadway and weaken the strength and proper settlement of the road. However, removal of the top soil may not always be necessary unless it contains these decomposed grasses, plants and other organic materials that may affect the quality of the road. Tools commonly used to remove the top soil include hoes, shovels, rakes and wheelbarrows.

After the top or surface soil is removed, the next task is excavation of the top soil. Therefore, in order to excavate the top soil, the following steps are used or followed:

- ♣ Dig several holes about 10 m apart to find out how deep the top soil is in the working area.
- ♣ Calculate the area each person or groups of persons can excavate, using the depth of the top soil measured divided into the volume of the daily task.
- ♣ Topsoil is usually loose and easy to excavate, so allow about 5 m³ per person as daily task. These, however, will be decided by the local climatic conditions and working culture of the given locality.
- ♣ Don't pile the top soil on the road side, but spread it on the agricultural land because the top soil is rich in organic matter and very valuable for crops.
- ♣ Consider spreading of topsoil on the sides of a road embankment to be grassed later for protection against soil erosion.

Another important job in feeder road construction is earthwork, which consists of formation, slotting, rocking, earth moving and compaction. The first step in making a road is formation, which is the excavation and shaping necessary to produce the correct cross section and allows room for ditches and side slopes. The important techniques in earthwork are organizing the excavation, setting

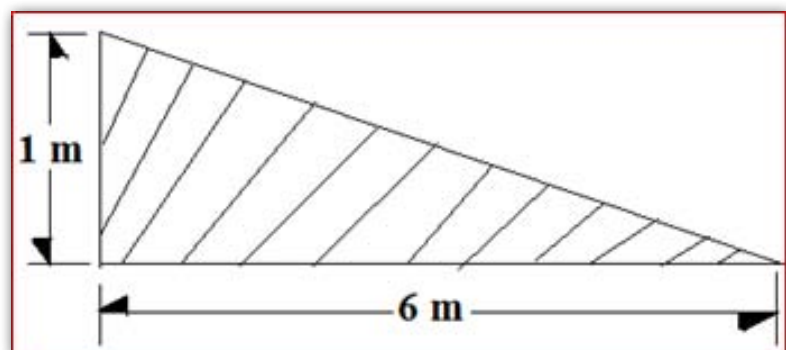

out the formation, calculating the earthworks, and organizing the labour force to do the work. To avoid drainage problems, in most cases the alignment of the road may have to follow the ground which will usually be aligned in the steep side along the ground or on the ridges of the terrain. In gentle slope terrain (less than 10% slope), you should choose the alignment to get equal cut and fill. In steep terrain and long ground (slope more than 10%) you should make all the formation in cut so that none of the earthwork is in fill which would be unstable. To calculate the percentage slope, divide the change in vertical height (VH) of the ground by the horizontal distance (HD) over which that change has happened. Then multiply the answer by 100. This will give you the percentage slope.

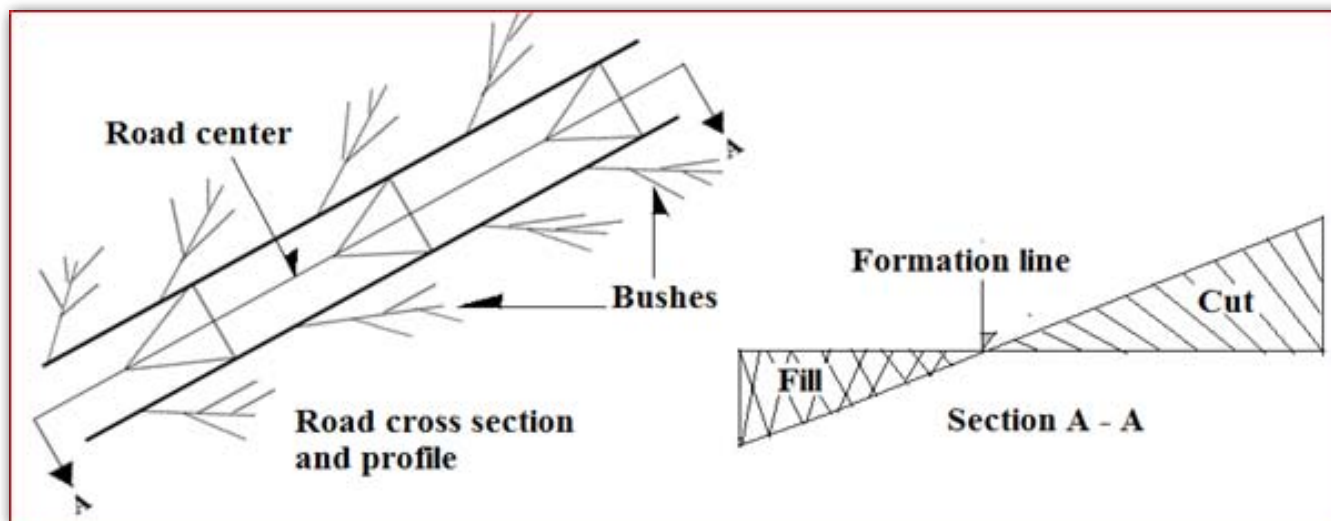

Fig 17.6 Cross section and profile for cut and fill (earthwork)

$$\text{Slope} = \frac{VH}{HD} \times 100 = \frac{1\text{m}}{6\text{m}} \times 100 = 16.7\%$$

17.5 Earth Moving for Community Road Construction

It is sometimes necessary to move common fill along the road to make the road level smooth. This important task is divided into three parts: (1) loading common fill; (2) hauling or transporting common fill; and (3) unloading common fills. For labour intensive road construction, hauling can be done effectively by light equipment, like shovels, stretchers, wheelbarrow, shovels, within short distances, up to 150m. For more specific earth moving distance, see Table 14.1 on the right.

Table 14.1 Different hauling method & distance		
Hauling distance, m	Method of hauling	Materials to be moved
0 - 10	Shoveling	Soil
0 - 50	Stretcher	Stone, soil
10 - 150	Wheelbarrow	Soil, stone
150 - 500	Animal carts	Soil, stone, water
500 - 800	Tractor trailers	Soil, stone, water

For loading earthwork like soils and gravel, shovels can be used. When unloading earthwork, unloaded materials are dumped close together, beginning at the far end of the fill. When using tippers, or tailors, the fill can be partially spread as the tractor moves forward dumping the load. The load should be dumped where it will not block the access for the next loading.

17.6 Advantages and Phases of Community Roads Construction

Community road helps improve communication for various social, economic and cultural activities; provides access for the residents/communities; facilitates development activities (tree planting, range land management, land productivity inputs and other multiple use activities); helps access to and from agriculture areas or lands; and helps access to marketing and other community services

Effective earthwork and labor cost of community road construction could be minimized through proper assessment of present and future uses to ensure maximum service with a minimum financial and environmental cost; proper location in relation to topography and soils; minimizing exposed constructed road surface; and using proper construction and culvert installation techniques. The basic parameters (design elements) in feeder road construction are length of the road; area of the road, volume of the work and depth of the ditch; and plan and cross section of the road.

The general sequential steps in feeder road construction are supporting the setting out the work to be done; site clearing (bush clearing, top soil and root removal, tree and boulder removal); earth work (excavation and filling, spreading and compaction); drainage (ditch excavation, culverts and bridge, erosion protection); and gravelling (excavation and loading, hauling and unloading, spreading, watering and compaction).

Some important concepts in community road standard construction include minimum horizontal curve radius (designed radius used to find out the proposed curve around sharp nosed ridges or steep draws); maximum spacing of passing curves/bays (additional space interval assigned to provide users convenience and safety to allow vehicles to maintain reasonable speed; scour checks (barrier structures constructed across the bed of ditch at intervals to reduce scouring/erosion effect).

The four phases of community road construction are (1) opening of 1.25m wide trail; (2) widening to 2.5 m wide track; (3) completion of earthwork and widening to 4.5m construction of structures; and (4) road finalization, bioengineering and completion of all road structures.

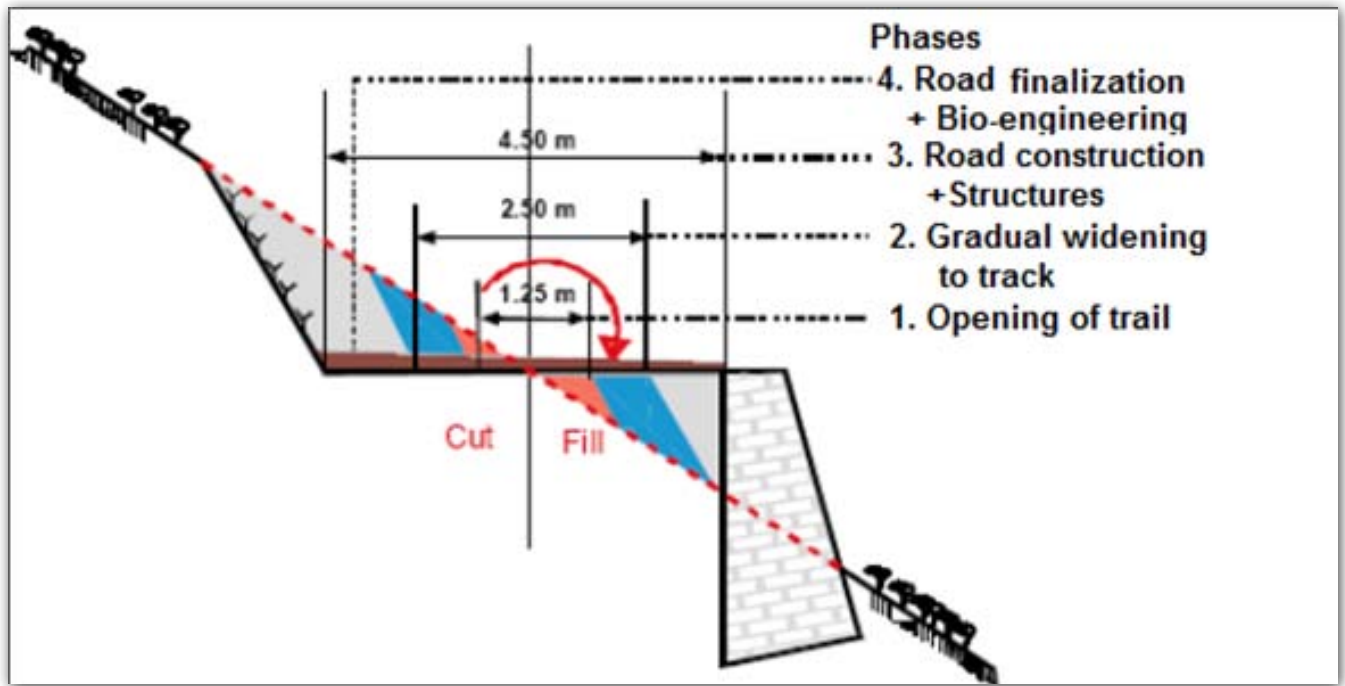

Fig 17.7 Phases of community road construction

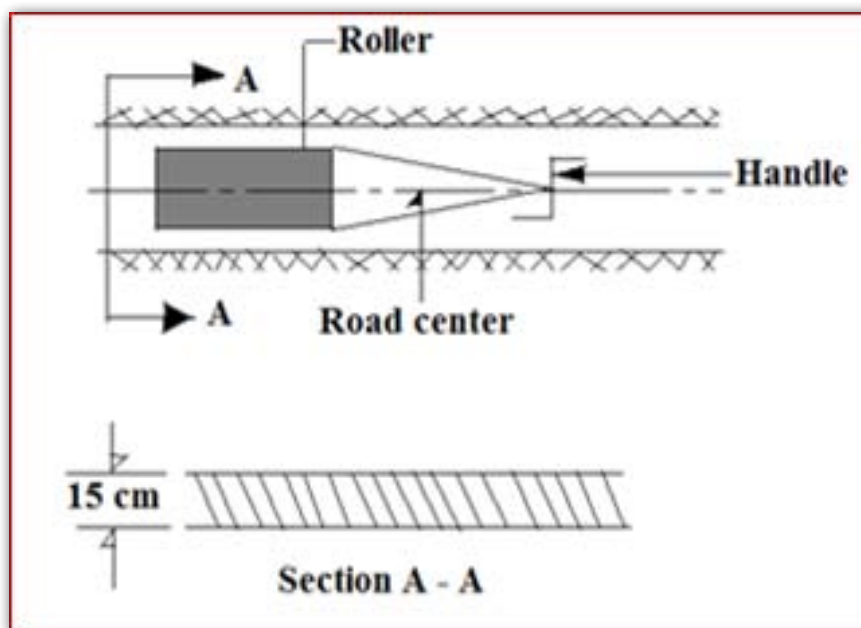

Fig 17.8 Compaction of a road with a roller

17.7 Compaction of Labour-based Community Road

A road which has been compacted can stand erosion and traffic better than a loose road embankment. Compaction is pressing the soil together to make it denser, by getting the air out of it. In such a way the soil becomes stronger and more soil particles touch each other. To achieve the best compaction, the right amount of water is needed to lubricate the soil particles so that they can compact properly. If there is too

little water, there is not enough moisture to let the soil particles compact together, and if there is too much water, the soil particles are held apart by the water and the soil becomes soft and cannot be compacted properly.

Compaction can be done by (1) natural consolidations, which sometimes can take up to six months, and is not very effective; (2) traffic, which may be available for simple roads; (3) hand hammers (these may be comfortable to handle) having the right diameter in relation to their weight, a ram with a diameter of 10 cm that weighs 7 to 8 kg can be used, and the layers of soil being rammed being less than 15 cm thick; (4) machines commonly used for compacting known as vibrating rollers.

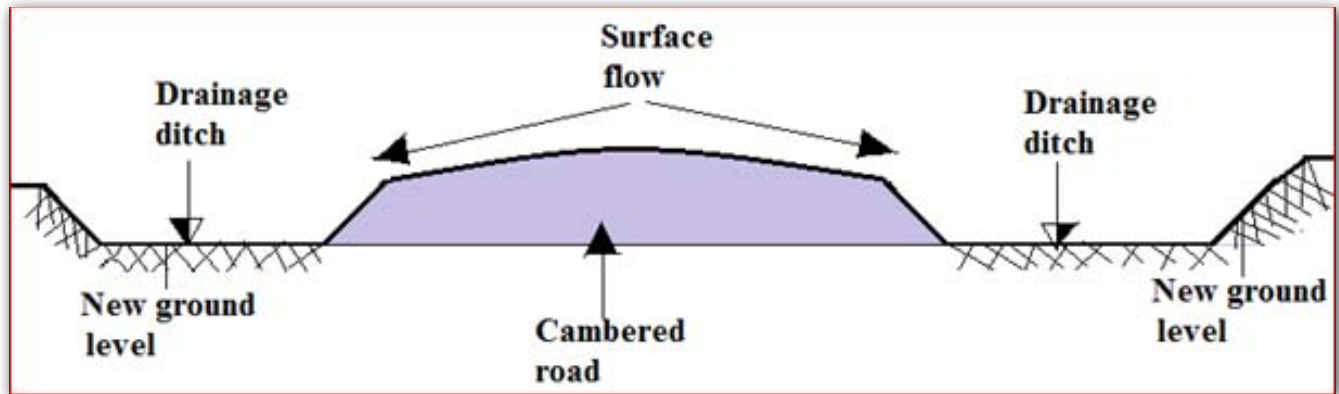

Fig 17.9 Excavating and spreading of soil on road surface

While compacting a road using a vibrating roller, make sure that each layer of soil to be compacted is not more than 15 cm thick. Otherwise, the roller cannot compact the soil properly. As a simple rule, the roller should pass over every point of fill for a minimum of 8 times, and ideally 13 passes are used. Make sure that compaction is also made along the line of the road and done uniformly. In most cases, water is not available for watering the soil because getting and transporting it would be too expensive. When this is so, try to prevent the moisture that is in the soil from drying out. In such a case, spread and compact the soil without delay after transporting. Spread and compact the soil in the morning when there may be some humidity, and go back and compact it at the end of the rain season. Please do not forget to compact the soil in layers of 15 cm thick each., Make sure you make 8 to 10 passes of rollers over every point of the soil layer made.

17.8 Drainage of Community or Feeder Roads

The most important factor for feeder or rural road construction is the provision of a proper drainage system. Excessive water or runoff can weaken the road, make it impassable or even wash it away. Therefore, proper drainage of a road should consist of road surface drainage, road side drainage, erosion control ditch, turnouts, cross drainage, drifts, culverts, vented fords and bridges. As water appears on the ground in different forms, such as ground water flow, surface water flow and flood water flow, a good road is the one which is well drained and allows all forms of water to flow away from it as quickly as possible.

A good drainage system consists of several components such as surface drainage that makes the water flow off the road quickly; side drainage that prevents water from reaching the road side; erosion control or score checks that slow down water in the ditches and prevent erosion; a catch water drain above the

road that catches water or runoff before it reaches the ground; cross drainage that allows water in the side drain to cross the road line by channeling it under or across the road; and turnouts that take water in the ditches away from the road and dispose it safely. Surface drainage prevents water from damaging the road by leading it off the road quickly, which is done by shaping the road to allow this water flow freely into the side drains. The slope that allows the surface water to flow from either side of the center line to the sides of the road is called camber. This type of sloping is used in open terrains with a ditch on each side. In a side long ground with only one ditch, it is better to use a cross fall.

For gravel and earth roads the cross fall or camber should be 5% to 7%. If the camber slope is 7%, it rises 7 units for every 100 units of horizontal length. The camber is made by spreading the soil which has been heaped along the center line in regular mounds during the formation of the side drains. Make sure that there is enough soil to make the camber at the correct angle. Ensure that the slope is also correct by using a camber board and a spirit level. Place the camber board cross wise on the road, with the spirit level on top, and use the spirit level to get the correct slope.

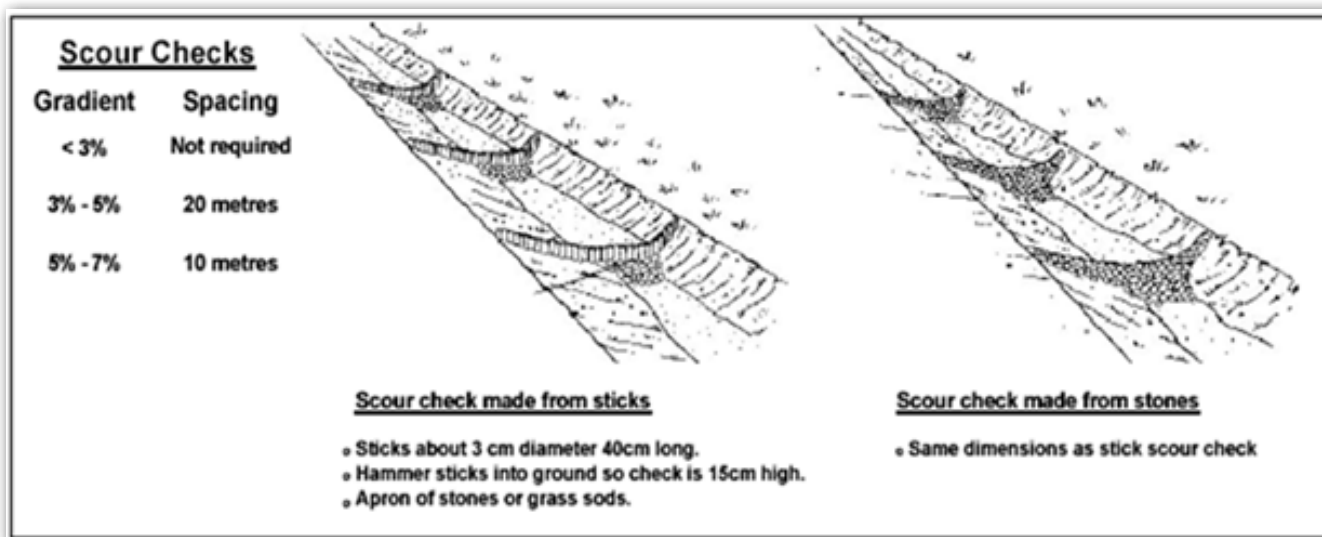

Fig 17.10 Labour intensive road construction on flat and rolling terrain (stable soil)

Minimum Horizontal Curve Radius	50 metres	DAILY WORK NORMS			
		General Norm - 3,000 person days / km			
Maximum Gradient	7%	Clear grass and bush (light)	150m ²	Compact by hand	100m ³
		Clear grass and bush (heavy)	50m ²	Collect stones (near)	1m ³
Max. Spacing of Passing Bays (Passing bays 20m long x 5m wide)	500 metres	Excavation (soft soil)	3m ³	Collect stones (far)	0.5m ³
		Excavation (hard soil)	2m ³	Break rocks	0.5m ³
		Excavation (rock)	0.5m ³	Scour checks	2/person/day
		Spread fill material	7m ³		

Table 17.2 Daily work norm for graveled community road on flat and rolling terrain (stable soil)

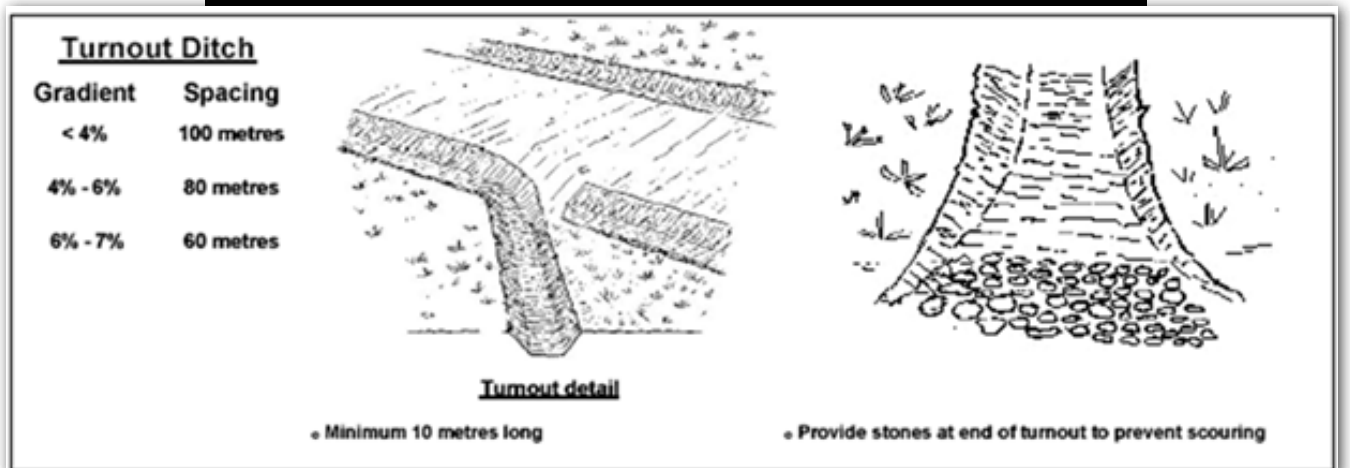
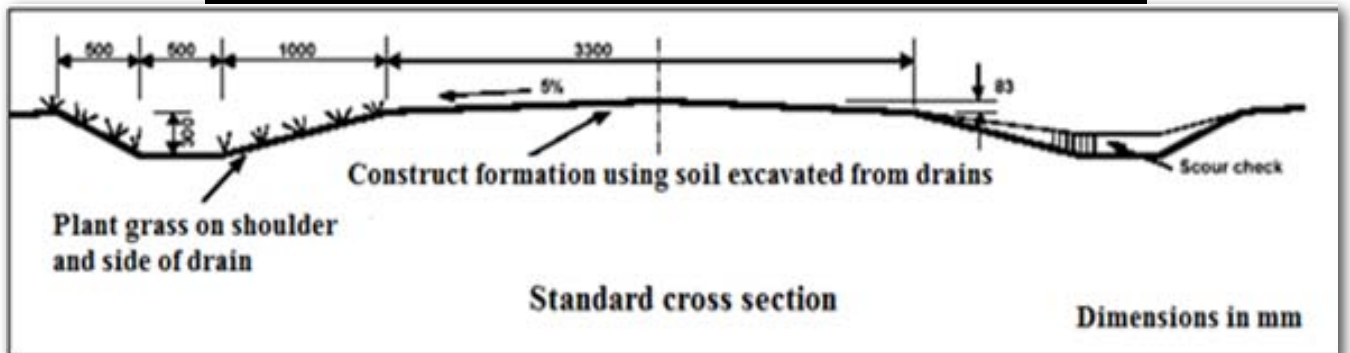
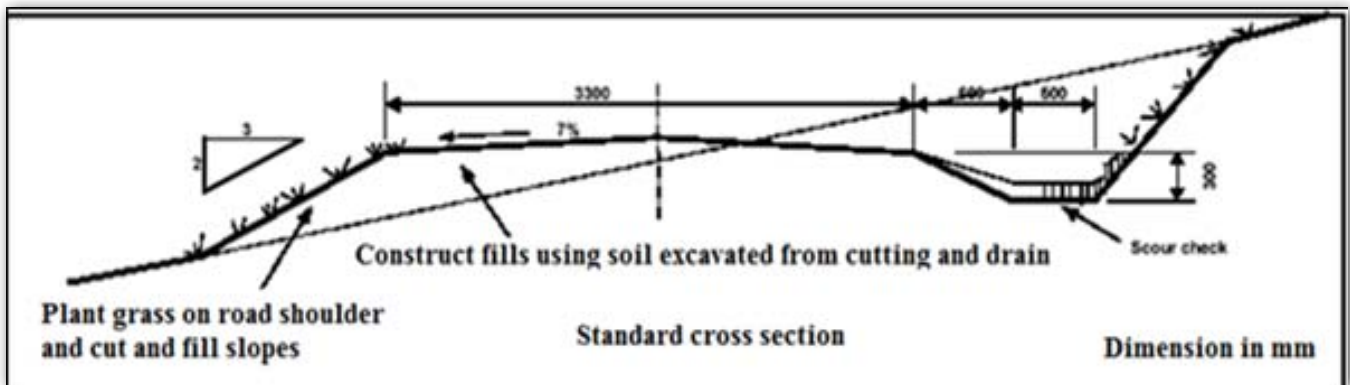

Fig 17.10 Labour intensive road construction on steps terrain (stable soil)

Minimum Horizontal Curve Radius	30 metres
Maximum Gradient	14%
Max. Spacing of Passing Bays (Passing bays 20m long x 6m wide)	200 metres

DAILY WORK NORMS			
General Norm - 4,000 person days / km			
Clear grass and bush (light)	150m ²	Compact by hand	100m ³
Clear grass and bush (heavy)	50m ²	Collect stones (near)	1m ³
Excavation (soft soil)	3m ³	Collect stones (far)	0.5m ³
Excavation (hard soil)	2m ³	Break rocks	0.5m ³
Excavation (rock)	0.5m ³	Scour checks	2/person/day
Spread fill material	7m ³		

Table 17.3 Daily work-norm for labor intensive road construction on steep terrain (stable soil)

17.9 Road Side Drains for Community Road

Road side drains or ditches collect water from the carriage way and prevents runoff water from the surrounding areas from reaching the road. The ditches, therefore, have to be large enough to cope with the runoff water coming from the catchment area. The side drain is constructed in two stages:

1. The ditch is made by digging a rectangular trench, and the soil is thrown into the center of the road.
2. The slopes are then cut from the edges of the ditch to the base of the trench, and again the soil is shoveled into the center of the road. These two stage methods of making the side drains make it easier to measure and to work on during construction.

Scour Checks	
Gradient	Spacing
< 3%	Nil
3% - 5%	20 metres
5% - 10%	10 metres
> 10%	Lined Drains (Engineering design required)

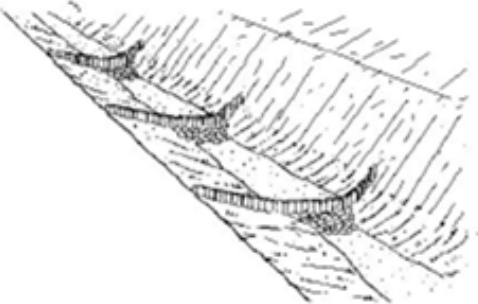

Scour check made from sticks

- Sticks about 3 cm diameter 40cm long.
- Hammer sticks into ground so check is 15cm high.
- Apron of stones or grass sods.



Scour check made from stones

- Same dimensions as stick scour check

Turnout Ditch or Culvert Spacing	
Gradient	Spacing
< 4%	100 metres
4% - 6%	80 metres
6% - 8%	60 metres
8% - 14%	40 metres

The construction will be easier and more accurate if a cut stick is used to measure the correct width and depth of the ditch. The design dimension of the stick is determined on the basis of the size of the catchment area that collects the runoff water into the road side ditch. Each worker involved in the construction of side ditch drains should have their own stick. Ditch template should also be available on the site for final checking. The task includes excavation and throwing the material into the middle of the road.

While constructing labour intensive community roads controlling the road sides from erosion is a very important and necessary measure to be applied. When water flows too fast, it can wash away the bottom or bed of the ditch. The faster water flows, the more soil it can erode and carry away. If the ditch becomes too deep, the road may collapse into it. Therefore, a method of erosion control is required to avoid this. There are various methods to control erosion, such as erosion checks which consists of lines of stones or wooden stakes constructed across the side drain to prevent the soil from washing away, and grassing along the side drain to strengthen the soil by knitting it together with the roots.

In making erosion checks from stones, cut a furrow about 10 cm deep and about 20 cm wide across the ditch. Then place stones close together in the furrow and each stone should be about 20 cm across. Don't place stones on top of each other as if you were building a wall. Spacing between checks depends on the slope of the terrain.

Bamboo or wood erosion control checks can also be used in areas where stones may not be available. The bamboo or wooden pole should be driven deep into the ground and if possible stones should be placed downstream so that the water falls on a hard surface without causing bed erosion.

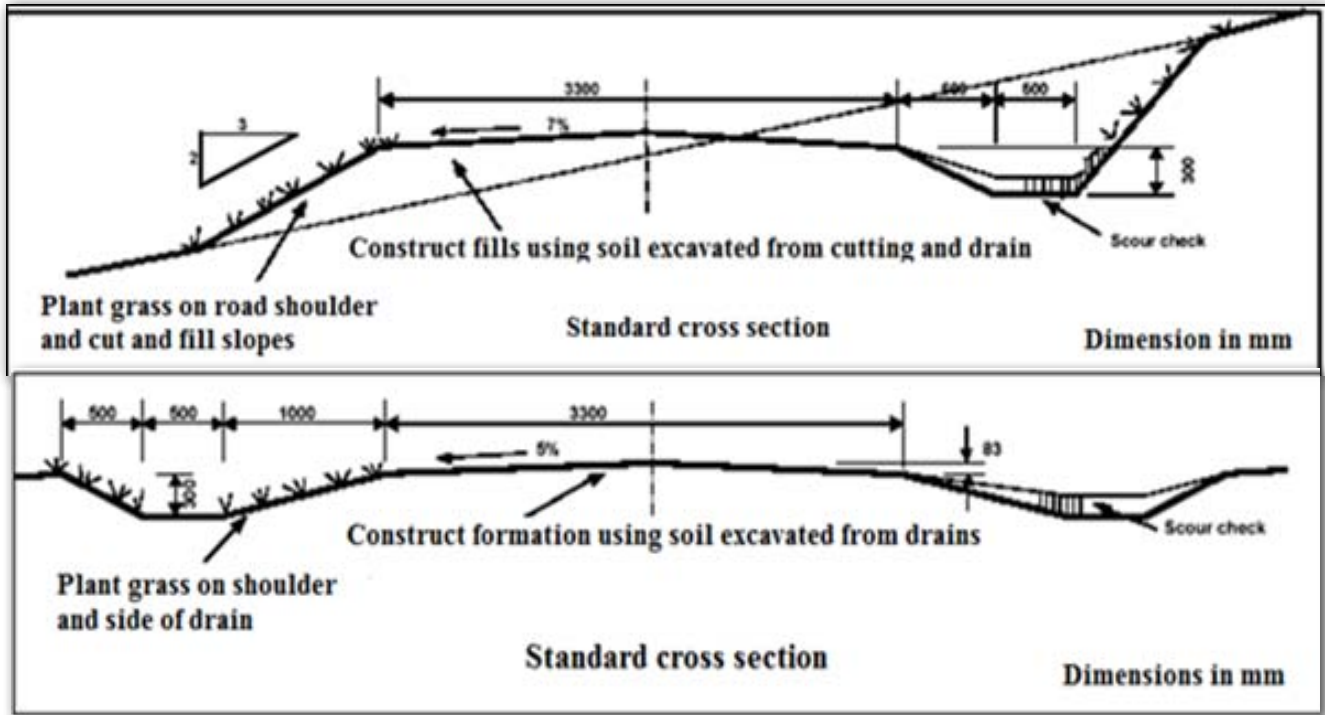

In order to avoid erosion of the side drains, grasses can be sodded on the side drains. In this case,

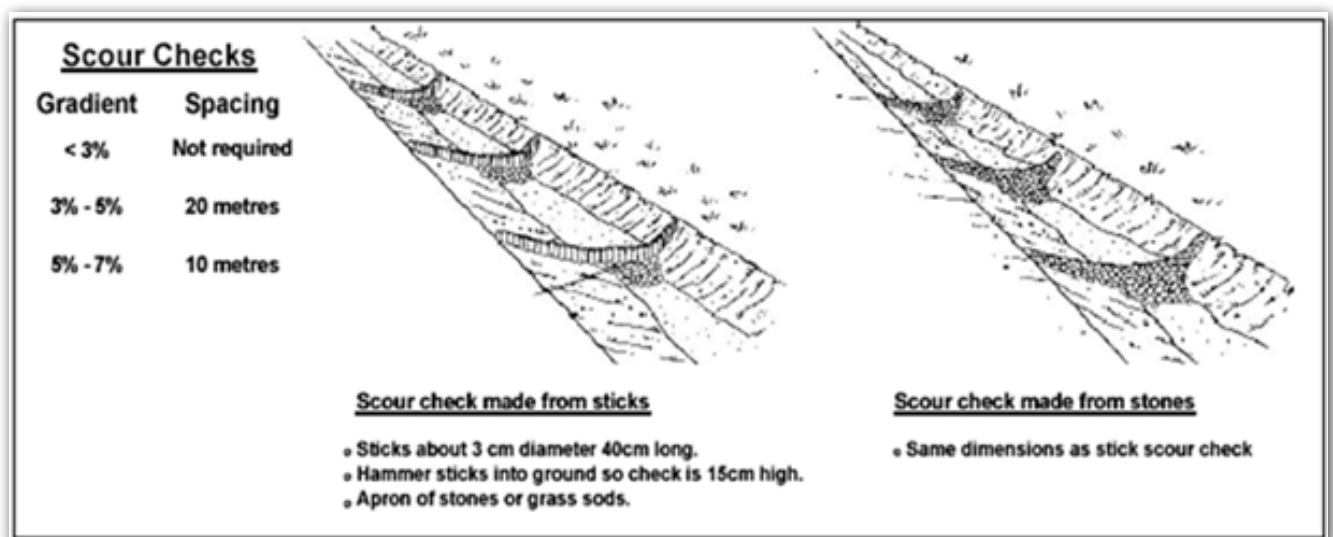



Minimum Horizontal Curve Radius	50 metres	DAILY WORK NORMS	
Maximum Gradient	7%	General Norm - 3,000 person days / km	
Max. Spacing of Passing Bays (Passing bays 20m long x 5m wide)	500 metres	Clear grass and bush (light) 150m ²	Compact by hand 100m ²
		Clear grass and bush (heavy) 50m ²	Collect stones (near) 1m ³
		Excavation (soft soil) 3m ³	Collect stones (far) 0.5m ³
		Excavation (hard soil) 2m ³	Break rocks 0.5m ³
		Excavation (rock) 0.5m ³	Scour checks 2/person/day
		Spread fill material 7m ³	

Table 17.2 Daily work norm for graveled community road on steep terrain

cut a narrow furrow along the ditch and plant it with the grasses. the most effective drainage techniques used to lead the water away from the side drains are the turnouts. A turnout or miter-drain leads water away from the side ditch or turnouts take water in the ditch away from the road side. Therefore, the more turnouts are provided the less likely the flooding will occur. However, turnouts are very difficult to get right. If they are too steep they will cause erosion in the land they lead on to, and if they are too flat, they will cause siltation or sedimentation problem. Hence, turnouts should have a minimum gradient of 2% and must gradually lead into the land getting shallower and shallower. It is also necessary to make sure that the discharged water from the turnouts is channeled toward the land boundaries to avoid damage to the farm land. If erosion is likely to occur, put a layer of stones on the ground at the end of the miter drain or side ditch.

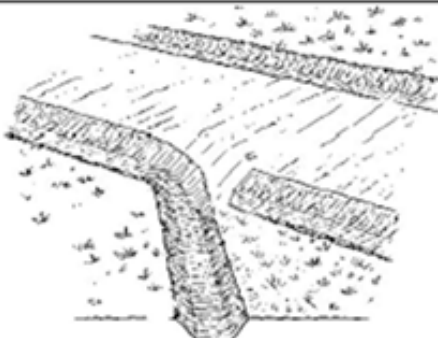
Minimum Horizontal Curve Radius	30 metres	DAILY WORK NORMS	
Maximum Gradient	14%	General Norm - 4,000 person days / km	
Max. Spacing of Passing Bays (Passing bays 20m long x 5m wide)	200 metres	Clear grass and bush (light) 150m ²	Compact by hand 100m ²
		Clear grass and bush (heavy) 50m ²	Collect stones (near) 1m ³
		Excavation (soft soil) 3m ³	Collect stones (far) 0.5m ³
		Excavation (hard soil) 2m ³	Break rocks 0.5m ³
		Excavation (rock) 0.5m ³	Scour checks 2/person/day
		Spread fill material 7m ³	

Turnout Ditch			
Gradient	Spacing		
< 4%	100 metres		
4% - 6%	80 metres		
6% - 7%	60 metres		
		Turnout detail	
		• Minimum 10 metres long	• Provide stones at end of turnout to prevent scouring

Scour Checks	
Gradient	Spacing
< 3%	Nil
3% - 5%	20 metres
5% - 10%	10 metres
> 10%	Lined Drains (Engineering design required)

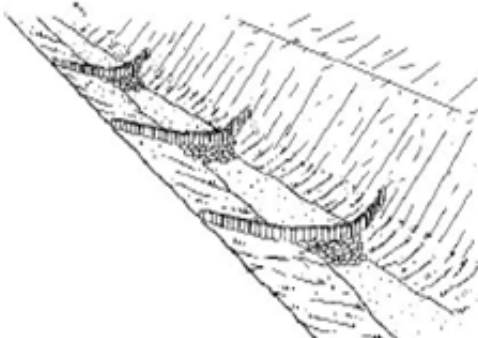

Scour check made from sticks

- Sticks about 3 cm diameter 40cm long.
- Hammer sticks into ground so check is 15cm high.
- Apron of stones or grass sods.

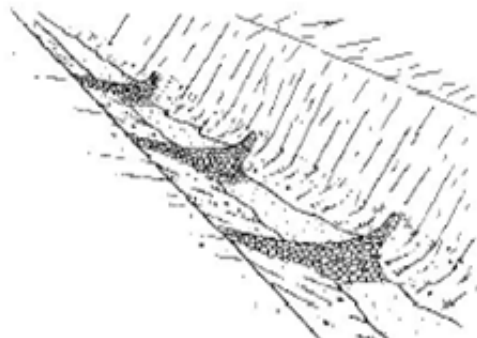

Scour check made from stones

- Same dimensions as stick scour check

Fig 17.14 Graveled community road on flat and rolling terrain (black cotton soil)

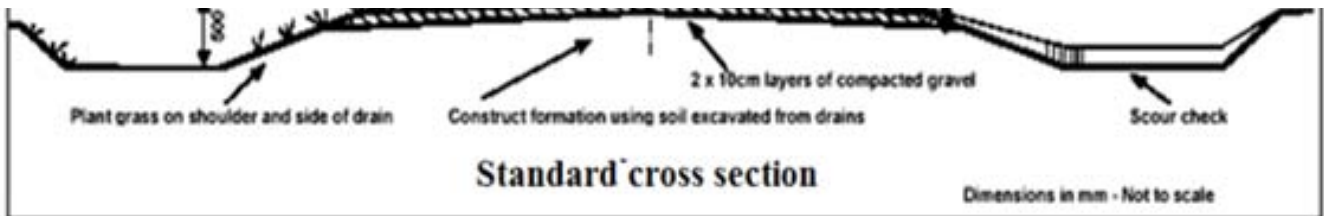

Scour Checks	
Gradient	Spacing
< 3%	Not required
3% - 5%	20 metres
5% - 7%	10 metres

Turnout Ditch or Culvert Spacing	
Gradient	Spacing
< 4%	100 metres
4% - 6%	80 metres
6% - 8%	60 metres
8% - 14%	40 metres

Minimum Horizontal Curve Radius	50 metres
Maximum Gradient	7%
Max. Spacing of Passing Bays (Passing bays 20m long x 5m wide)	500 metres

DAILY WORK NORMS			
General Norm - 4,500 person days / km			
Clear grass and bush (light)	150m ²	Compact by hand	100m ²
Clear grass and bush (heavy)	50m ²	Collect stones (near)	1m ³
Excavation (soft soil)	3m ³	Collect stones (far)	0.6m ³
Excavation (hard soil)	2m ³	Break rocks	0.6m ³
Excavation (rock)	0.6m ³	Scour checks	2/person/day
Spread fill material	7m ³		

Table 17.6 Daily work norm for gravelled community road on flat and rolling terrain (black cotton soil)

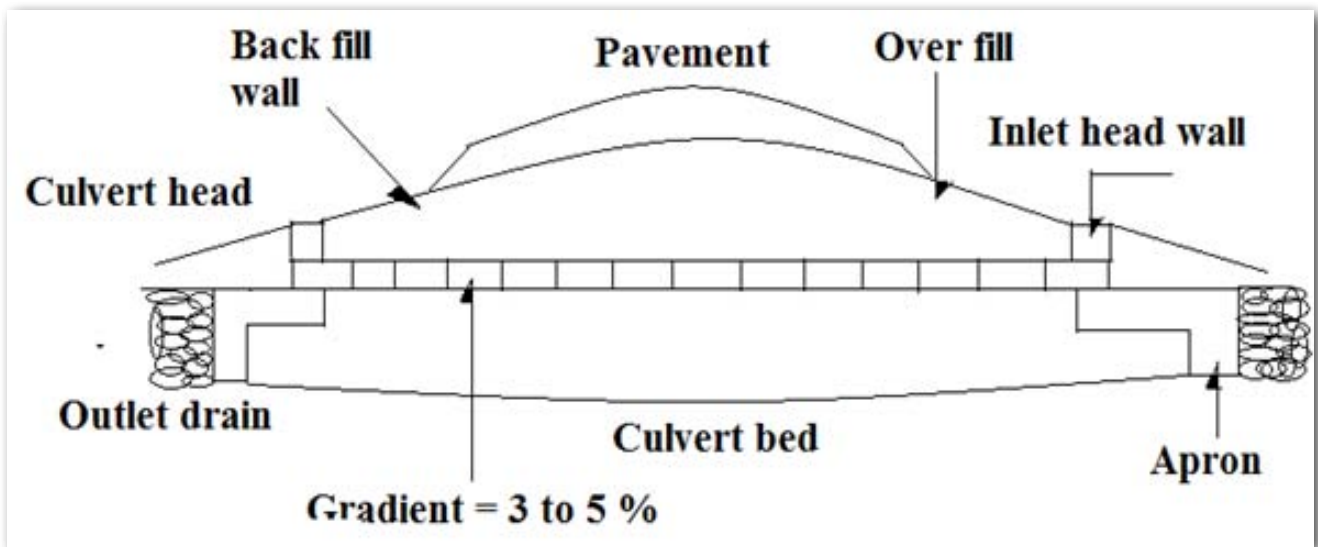
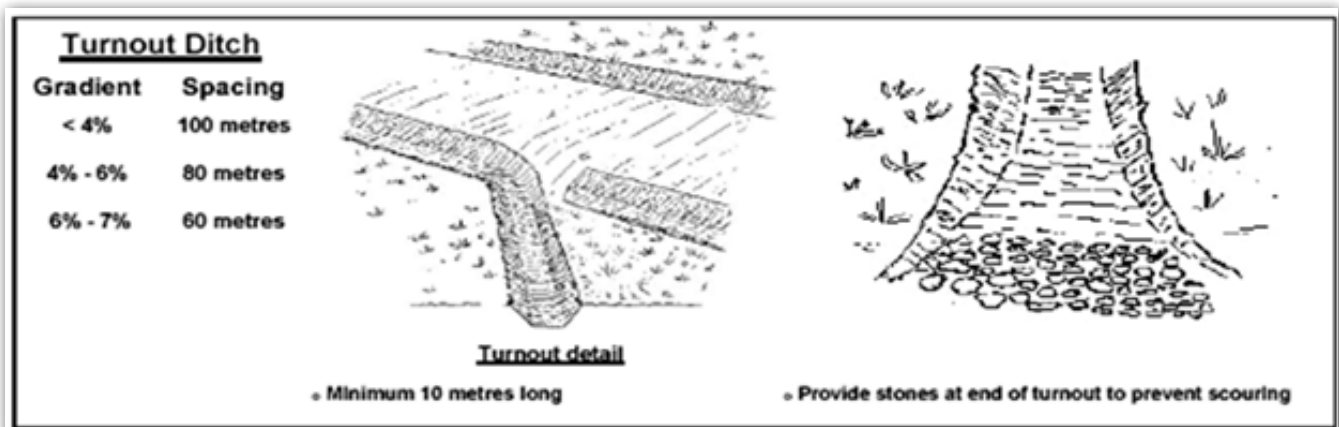

Fig 17.15 Cross sectional view of a culvert



17.10 Cross Drainage for Community Road

Cross drainage is almost always required on community road or any road. This is because it is necessary to lead the runoff water from higher ground on one side of the road to lower ground on the other side. Cross drainage is required whether the road goes down or uphill from both directions to a low point. At this point, water collects and the cross drainage is needed to let the runoff water pass to the other side of the road.

Various structures allow cross drainage to take place and the type used depends on how much water is expected to flow through the structure during a peak flood. The quantity of water flowing through the cross drainage depends on the area of land or catchment, amount of runoff coming into the cross drainage and the shape of the catchment. The most common types of cross drainage are drifts, culverts, vented fords, minor bridges, and major bridges. Drifts allow water to flow across the road on the surface, and they are cheap and easy to construct and are well suited to roads with relatively little traffic. Culverts are usually made of a single line of concrete pipes, normally not less than 60 cm in diameter to avoid blockage, and are placed in trenches and covered over to carry water under the road. Concrete pipes can be made on the site, or transported to where they are required.

The most common diameter sizes of culverts are 60 cm to 90 cm. If culverts are smaller than 60 cm diameter, they can be blocked easily and if they are bigger than 90 cm diameter, they are difficult to handle. Vented fords are usually needed where a large flow of runoff water is likely/expected to flow into it. Vented fords are also called vented drifts. Minor bridges are similar to vented fords except that pipes are replaced by corrugated iron roofing sheet, surrounded by concrete. However, major bridges are a very complex subject and are beyond the scope of this manual. The important techniques to construct a culvert include:

- ♣ Set out and excavate the outlet drain if necessary.
- ♣ Excavate a trench. The width would be about 1.50m times the diameter of the culvert.
- ♣ The depth should be the diameter plus the cover shown in Table 17.7 below.
- ♣ Form the bottom of the trench so that it is gently sloping (3% to 5%) in the direction of flow
- ♣ Gently place the pipes in the trench and line them up accurately with crowbars.
- ♣ Place the soil around the pipes in layers and compact each layer with rammers.
- ♣ Now remove the excess soil and tidy up the site.
- ♣ After two weeks, come back and level the road over the culvert to correct any settlement that has taken place.

Type of pipes	Diameter of concrete pipe, cm	Depth of cover, cm
Spun concrete	60	30
	90	45
	120	60
Concrete cast on site	60	45
	90	70
Corrugated steel (circular or elliptical)	60	30
	90	45

It is vital that culverts have enough soil above them to spread the load or traffic. Table 17.7 on the right gives the depth of soil cover and diameter of various types of pipes.

17.11 Gravelling of Labour-based Community Roads

Gravelling of access roads consists of work in quarries, haul/unload and spread and compaction of selected materials. An access road construction needs a strong surface layer which allows expected traffic loads to pass in dry and wet weather. A good gravel road is one which remains strong and does not become slippery even when wet; is not washed away by the flowing water; and can be excavated by hand (for labour-based works).

A good gravel should have a mixture of 50% stones, 40% sand and 10% clay in rough proportion. Gravel contains stone for strength, sand to fill the gaps between the stones and clay to bind the stones and soils. Gravel roads are stronger and last longer than the earth roads. However, gravel is expensive, because it requires excavation, transport, spreading and compaction.

The basic procedure for community road construction work :setting for support are: site clearing (bush clearing, top soil and root removal, and tree and stump removal, boulder removal); earthworks (excavation and filling, spreading and compaction); drainage (ditch excavation, culverts and structures, erosion protection); gravelling (excavation and loading, hauling and unloading, spreading, watering and compaction).

The most common tools used for the construction of a labour-based community road include: hoes, shovels, slashers, buckets, feathers, mattocks, crowbars, axes, sledge hammers, chisels and tongs, forked hoes, wheelbarrows, earth-rammers, wedges, safety glasses, pick-axes, bush knives, rakes, plugs and others. Other miscellaneous tools or items used for feeder or community road construction are oilstones, camber board, straight edge, spirit level, meter tape, abney level, boring rods, line levels, range rods, first aid kit and equipment for watering.

Chapter 18

Methods of Compost Preparation

18.1 Description

Compost is a decomposed organic matter or fertilizer, such as crop residues and animal manure, that can be made at very low cost. Most of these ingredients for compost-making can be easily found around the farm, and the most important input for preparing compost is the labor from farmers.

Due to soil fertility problems, crop returns often decrease and the crops are more susceptible to pests and diseases because they are in bad condition. Hence, in order to increase soil fertility in the short-run, nutrients like chemical fertilizers are applied to the soil. Chemical fertilizer, however, is expensive to purchase for most small-scale farmers and this is a problem. Therefore, preparation and use of compost, which contains valuable nutrients and organic matter, can be a solution to improve soil fertility, improve soil structure and increase organic matter content of the soil in the long run. Though a very large quantity of compost is needed, in order to maintain the soil fertility in the long-term using compost as a good fertilizer is the only means to maintain soil fertility.

The organic fertilizer methods that can improve soil fertility include mulching, green manure, liquid manure, animal manure, etc. Composting animal manure makes a better fertilizer. It should, however, be matured for some time, otherwise it might have a burning effect and damage the plants or crops.

18.2 Advantages

Organic matter in the soil is fundamental in maintaining soil fertility and decreasing nutrient losses. Compost as an organic fertilizer adds organic matter and nutrients to the soil. In order to quickly supply a crop with the required nutrients, a chemical fertilizer helps the plants immediately, but it is used up by the end of the season. However, organic fertilizers have first to be broken down into nutrients (by soil-organisms) before they can be utilized by the plants or crops to continue to enhance soil fertility, soil structure and water holding capacity of the soil.

Moreover, the presence of organic matter ensures that the chemical fertilizer is utilized more efficiently by the crop, retains plant nutrients and prevents the fertilizer from being washed away. It is, in fact, a waste of money to apply chemical fertilizer on soils that are poor in organic matter, if it is not done in combination with measures to increase the level of organic matter in the soils.

18.3 Processes of Decomposition

Organic matter in the soil consists of fresh organic materials and humus, such as dead plant material, animal droppings, live products, etc. These fresh organic matters are transformed into fine organic matter and humus by soil organisms and give the soil a dark color and retain nutrients and water.

These decomposed fine organic matters and humus have the following properties:

1. Improve the soil structure;
2. Improve resistance of soil against erosive action of rain and wind;
3. Retain water and release it slowly and water is available to the plants over a longer period;

4. Retain nutrients and release them to the plants slowly over a longer period;
5. Contain the main nutrients like nitrogen (N), phosphorus (P) and potassium (K), which become available to the plants after decomposition.

In a hot climate the micro-organisms are more active and the organic materials will break down more rapidly than in a cold climate. The acidity of the soil, the composition of organic matter, humidity and availability of oxygen strongly influence the rate of decomposition.

18.4 Process in Compost Preparation

Organic material is collected, and preferably stacked in pits or heaps. In the heap method, the decomposition process is more intensive and the condition is more favorable because the heap is made up of almost entirely organic matter. The end product is strongly decayed organic matter with humus and nutrients. This is known as compost (organic fertilizer that can be added to the soil). Adding compost to sandy soils increases the water retention capacity and water remains longer and available in the soil to plants for a longer time in drought or dry periods. All non-toxic organic materials can be used for making compost. Composting process happens due to the activity of micro-organisms (bacteria) and other larger organisms like worms, insects, etc.

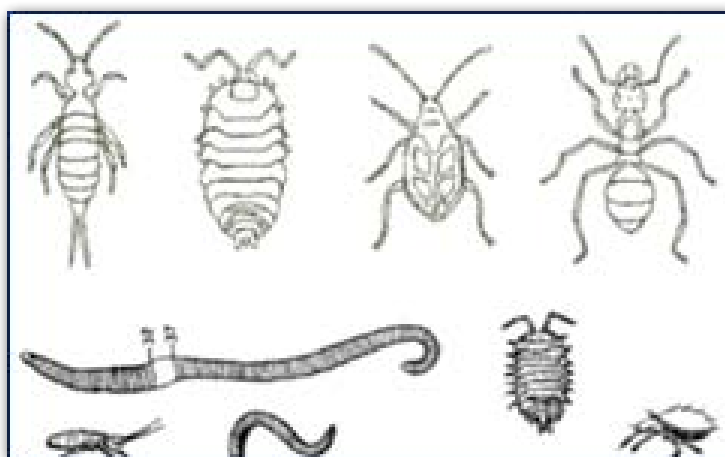

Fig 18.1 Important micro-organisms for decomposition

These need certain conditions for the micro-organisms. These include moisture and air. To make the best possible compost, micro-organisms must be able to work optimally. This can be achieved if the following four factors are combined to the best advantage: (1) type of organic material (2) air (3) moisture, and (4) temperature.

The acidity (pH) is also considered to be an important factor and it depends on the air and moisture flow. A compost heap that is properly composed will seldom get too acidic and the composting process will be optimal when (a) various materials of different decomposition rates are combined (b) different materials are well mixed; and (c) the size of the heap varies from 1 by 1 meter to 3 by 3 meters. This makes it possible for the temperature to stay constant within the heap.

A good composting process passes through 3 consecutive stages:

- * a heating phase (fermentation);
- * a cooling down phase; and
- * a maturation phase.

This process takes place very gradually and with the help of continuously changing microorganisms that convert the organic matter into compost.

18.5 Organic Material

The micro-organisms which decompose the organic matter need both carbon and nitrogen to function well. In general, young living material that decomposes fast contains low levels of carbon but high levels of nitrogen. Tough dead material decomposes slowly and contains large amounts of carbon but low amounts of nitrogen. Too little nitrogen-rich material means the composting process will be slow, while too much of it will result in the heap becoming acid and smelly. The ideal ratio of carbon to nitrogen for starting a compost pile is 25-30 to 1 (that is 25-30 Carbon to 1 Nitrogen).

Examples of nitrogen-rich materials are young leaves, all types of manures, fish meal, fish waste, urine, leguminous plants; and examples of carbon rich materials are dry leaves, crop residues of maize, sugarcane, rice, twigs, wood-shavings, coffee pulp, carton, etc.

The recommended size of compost heap is 2 to 2.5 meters wide and 1.5 to 2 meters in height. The length depends on the quantity of organic material available, but it is better to make a shorter heap than a longer heap.



Fig 18.2 Layering of materials for compost preparation

It is strongly advised to start with a heap greater than 1 cubic meter, otherwise the temperature in the heap remains low and decomposition is too slow and incomplete. During the maturation phase the volume of the heap decreases, and the heap sags in, as it were.

18.6 Methods to Make Compost

Taking into account the availability of organic materials and weather conditions, there are many ways of making compost, and a choice can be made from these methods. It can be Indore Method or building a heap. The basis of a heap should consist of twigs and cane shoots.

The following successive layers are piled on top of this:

1. a layer of about 10 cm tough organic material which is difficult to decompose;
2. a layer of about 10 cm fresh organic material which decomposes easily;
3. a layer of 2 cm animal manure, compost or slurry from a biogas tank; and
4. a thin layer of soil.

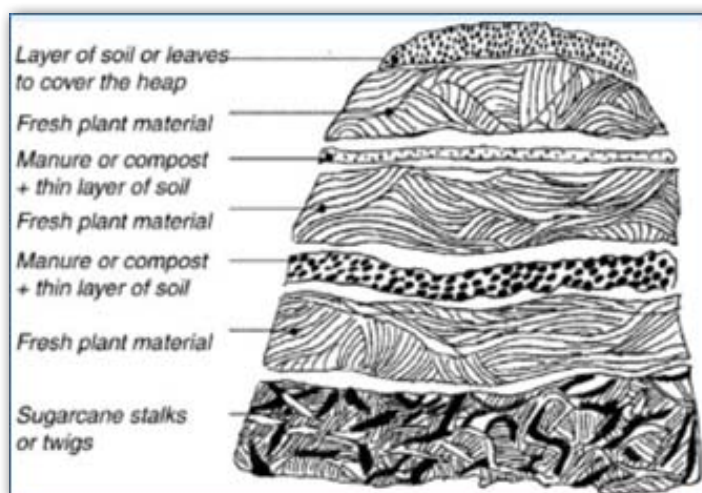

Fig 18.3 Compost heap preparation

The soil should be collected and should come from the top layer (top 10 cm) of clean moist soil (e.g. from under trees). This ensures that the right micro-organisms are brought into the heap. This sequence of layers is repeated until the heap has reached a final height of 1.5 to 2 meters. In this way the heap is composed of many layers. Building the heap should be done quickly, preferably within a week.

18.7 Turning over Compost Heap

During decomposition the heap has to be turned over regularly in order to remain well aerated and converted into compost. The first turning over of the heap should be done after 2 to 3 weeks. The heap is broken down and built up again next to the old heap. The layers are mixed and the heap is turned upside down and inside out. Again, a foundation of coarse plant material is made first. Then the drier and outer less decomposed part of the old heap is placed in the central part of the new heap. The drier material will have to be watered before the heap can be built up further. This core is covered with the rest of the material, and the original layered structure is lost.

The second turning-over takes place after 3 weeks and it may even be necessary to turn the heap over again for a third time. Repeat the moisture test and the temperature test a few days after each turning-over operation. Under favorable conditions, decomposition process in the Indore Method takes 3 months, but under adverse conditions it may take longer than 6 months. Some substances, such as human urine and wood-ash promote the growth of the micro-organisms. A small amount of these in the heap is sufficient to accelerate their growth. If the process has to be speeded up spread some urine or wood-ash over the thin layers of soil, but only in small quantities - too much ash kills the micro-organisms. Urine, diluted with water 1:4 is sprinkled over the heap, using a watering can. The Indore Method usually gives good results.

18.8 Pit Compost Preparation

This method involves making compost in pits that have been dug in the ground. The best depth for a pit varies according to local soil conditions and the depth of the water table. A typical pit would measure 1.5 to 2 m wide, 50 cm deep and any length. The pit can be lined with a thin layer of clay to reduce water loss. Often, several trenches are dug next to each other, to allow turning from one pit into the next. Material should be placed in the pit in layers as described below. For a larger pit measuring 2 m wide by 2 m long and 1 m deep, 1 to 1.5 liters of water should be poured on before applying the layer of soil, which seals the pit.

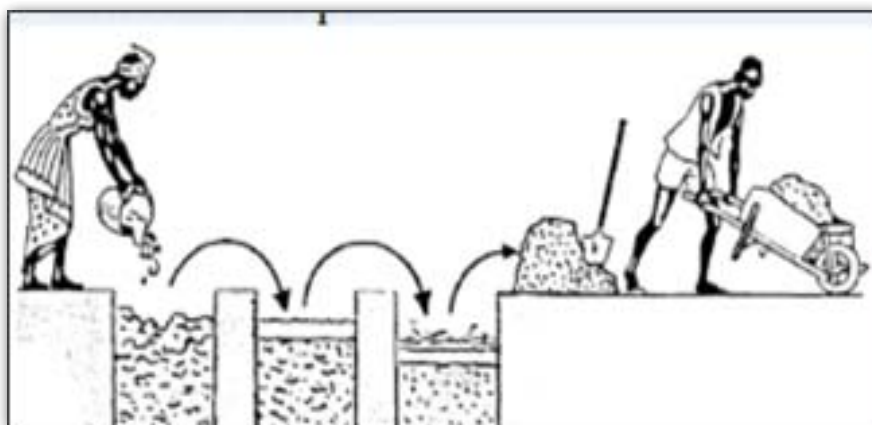

Fig 18.4 Compost pits preparation

The layering is as follows:

1. 10 cm of material, which is difficult to decompose (twigs, stalks);
2. 10 cm of material which is easy to decompose (green and fresh);
3. 2 cm of animal manure (if available);

4. A thin layer of soil from the surface of arable land to obtain the micro-organisms needed for the composting process. Repeat these layers until the heap reaches 1 to 1.5m high; and,
5. Cover with grass or leaves, such as banana leaves, to prevent water loss.

After 2 to 3 weeks, all the contents of the pit should be turned over into the second pit and 2 to 3 weeks later this should be turned into the third pit. As the decomposing material from pit 1 is turned into pit 2, new material, which is ready for composting, can be put into pit 1, thus creating a process of continual compost making. The advantage of pit composting is that it is quick, easy and cheap as it does not require investment in materials. It needs less water so it is useful for dry areas. The disadvantage of a pit composting is that it is more difficult to follow the decomposition process than a pit with an above ground heap.

18.9 Trench Compost Preparation

Trench composting is similar to pit composting except that plants are grown directly onto the trench as opposed to taking the compost out of the pit and spreading it on land. A trench should first be dug. The size of trench depends on how much material you have available and how many plants you are planting in the trench.

The width can range from 50 cm to several meters; while the depth should be 1 m or less. It can be any length. It should then be filled as follows:

1. 10 cm of material which is difficult to decompose (stalks or crop residues);
2. 10 cm of material which is easy to decompose (fruit and vegetable scraps);
3. Add 2 cm of animal manure (if available);
4. A thin layer of soil from the surface of arable land to obtain the micro-organisms needed for the composting process;
5. Repeat these layers until the pile is about 50cm above the ground;
6. Cover with soil, grass or leaves (such as banana leaves) to prevent water and nutrient loss and leave to settle for about one month before planting.

Trench composting is especially useful against termites attack as most species live above ground level.

18.10 Caring for Stored Compost

Compost should never be left uncovered in the rain or in the sun. The rain washes out the nutrients and the sun can cause burning when then the compost loses its fertility. To reduce this loss, the compost should be covered with some useful covers like banana leaves, intertwined palm leaves or a sheet of plastic. If the compost is left too long, it may also become a breeding place for unwanted insects, such as termites and the rhinoceros beetle.

Chapter 19

Design of Small and Medium Scale Irrigation

19.1 Description

Small-scale irrigation can be defined as irrigation on small plots, in which small farmers have the controlling influence. Small-scale irrigation is therefore a farmer-managed intervention. Farmers must be involved in the design process, particularly with decision about boundaries, layout of canals, position of outlets and crossings or bridges. Small-scale irrigation covers a range of technologies to control water from floods, stream flow, or pumping.

Crops require a large amount of water for irrigation and it is important to calculate water requirements accurately for both designing the supply canal and the pump (if any) and checking that adequate water is available from the source. The amount of water required by a crop depends on the local environment, the climate, the crop and its stage of growth, and the degree to which the crop may be stressed. The requirement may be expressed as a uniform depth of water over the area in millimeters per day (mm/d).

19.2 Irrigation Requirements

Reference evapotranspiration (ET_o) is the water use of grass (in mm/d) under standard conditions. Local estimates may be available from meteorological offices. Typical values are shown in Table 19.1. For most crops, the reference evapotranspiration at mid-season can be taken as reasonable estimate of the peak water requirement. It is reasonable to assume that 70% of average rainfall is available to the crop, and the net irrigation requirement (I_n in mm/d) can be estimated as:

$$I_n = ET_o - (0.70 \times P)$$

Where: P is the average rainfall, mm/d.

Additional water has to be supplied to take account of field application losses, which, with surface irrigation, are typically about 40%, given an application efficiency of 0.60. The field irrigation requirement (I_f) can be estimated as:

$$(I_f) = I_n / 0.60 = \{ET_o - (0.70 \times P)\} / 0.60$$

The field irrigation requirement represents the rate (in mm/d) at which water must be delivered to the field to prevent the crop suffering from shortage of water.

19.3 Designing Command Area

The required canal discharge depends on the field area to be irrigated (known as command area), and the water losses from the canal. For a designed command area A (m^2), the design discharge required Q (l/s) for irrigation hours (H) every day is given by the field irrigation requirement multiplied by the area, divided by the time (in seconds).

$$Q = (I_f \times A) / (H \times 60 \times 60) + \text{canal losses}$$

Where:

Q = design discharge in l/s

A = designed command area in m²

I_f = Irrigation Field requirement in mm/d

H = irrigation time in hours

19.4 Water Losses through Irrigation Canal

Water is lost from canals by seepage through the bed and banks of the canal, leakage through holes, cracks and poor structures, and an overflowing low section of bank. The canal losses depend on the type of canal, materials, standard of construction and other factors but are typically about 3 to 8 l/s per 100 meters for an unlined earthen canal carrying 20 to 60 l/s.

Losses often account for a large proportion of water requirements in small scale irrigation, and may be estimated by ponding water in a trial length of canal, and then measuring the drop of water level. When the water surface width in the canal is W meters, a drop of S millimeters per hour corresponds to an average canal loss of:

$$[W \times S] / [60 \times 60], \text{ l/s per meter length.}$$

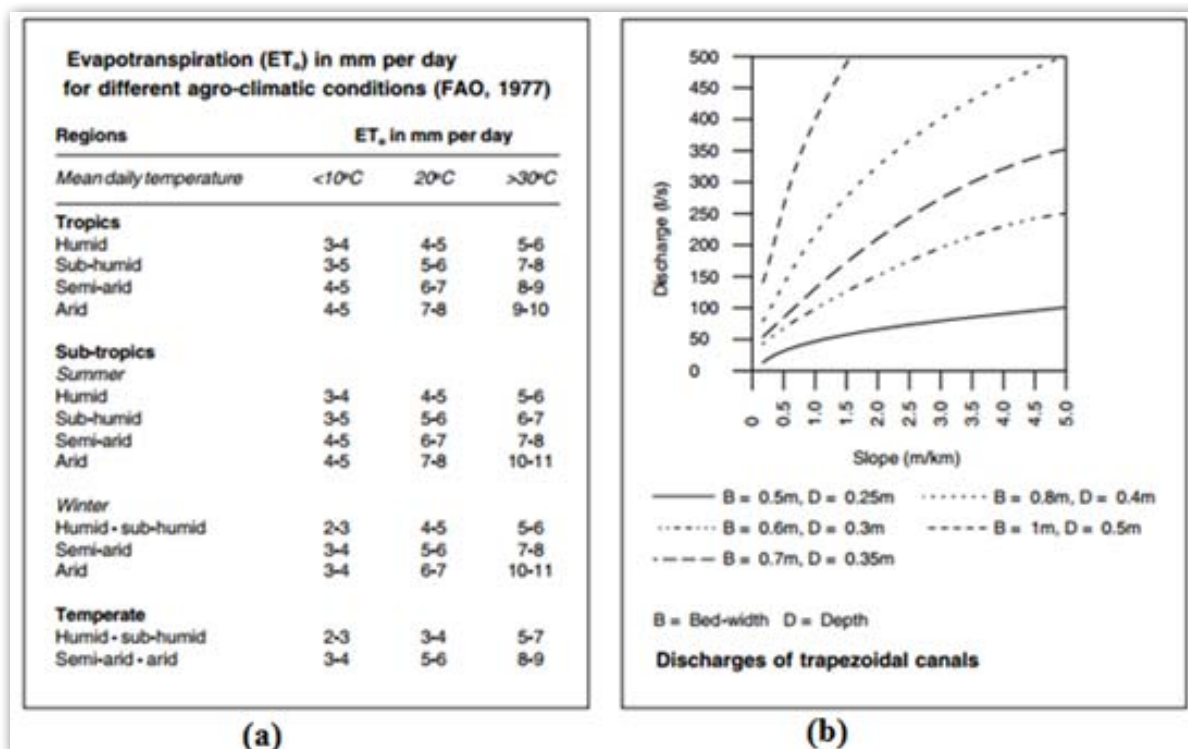

Table 19.1: Evapotranspiration (ET_o) in mm/day for different agro-ecological conditions

19.5 Irrigation Canal Design

Water may be conveyed from the source to the field by unlined or lined canal, pipeline, or a combination of the two. The unlined canal is the most common method in use. A typical cross-section of an unlined earthen canal for small-scale irrigation is shown in Fig19.1

To minimize the losses, the canal banks should be built from clayey soil and constructed in layers, with each layer compacted using heavy rammers. The required size of the canal can be decided using Manning's formula: A design chart such as Table 1 (b) can be used to calculate the discharge:

$$Q = \frac{A \times R^{0.67} \times S^{0.5}}{n}$$

Where:

Q = peak discharge (m³/s) - Note; 1 m³/s = 1000 l/s)

A = wetted area of the canal (m²)

R = Hydraulic radius, m (= wetted area/wetted perimeter)

S = slope (fraction)

n = Manning's roughness coefficient (commonly taken as 0.03 for small scale irrigation canal).

For example, for a trapezoidal canal in clay soil with side slopes of 1 to 1.5, a design discharge of 44 l/s, and a slope of 0.001 (or 1 m/km), uses a bed width (B) of 0.5 m and a depth (D) of 0.25 m.

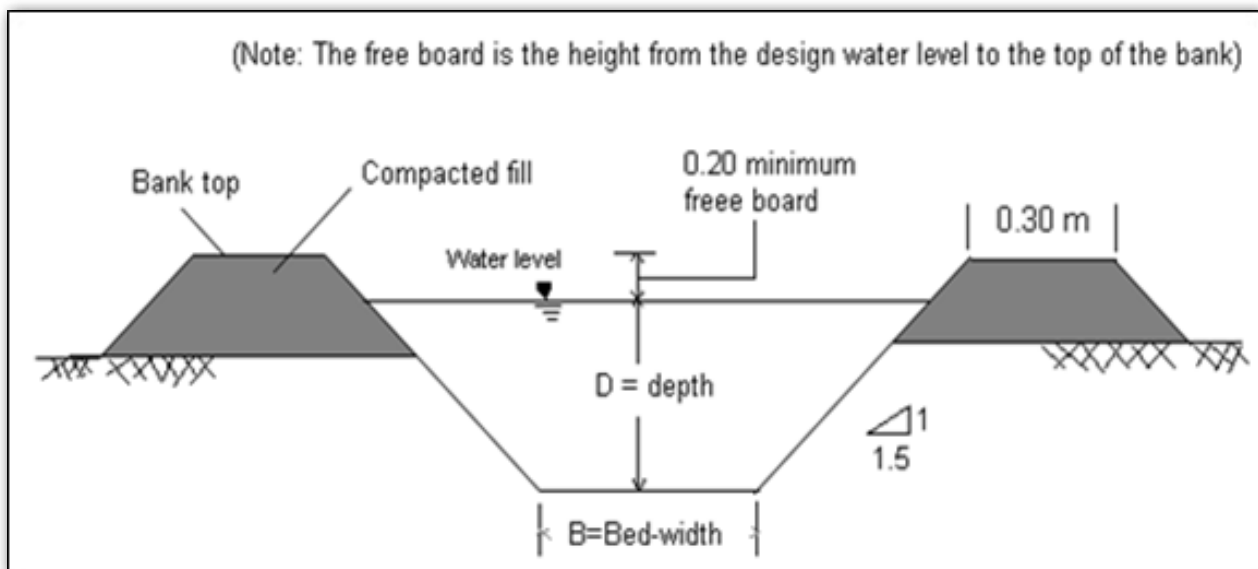

Fig 19.1: Typical cross section of an unlined earthen canal

19.6 Design Discharge

Design discharge of an irrigation field can be determined by using different hydraulic methods. For example, according to Chezy's Formula, for uniform flow in an open irrigation canal, the velocity of water can be expressed by the following formula:

$$V = C \sqrt{R i}$$

Where,

V = Velocity of water through the canal, m/sec;

c = Chezy's constant - its value depends upon the roughness of the inside canal.

R = Hydraulic radius of the canal, m

i = hydraulic gradient of the canal.

When the surface of the channel is smooth, there will be less frictional resistance to the motion of water and the value of c will be more:

$$R = \frac{A}{P}$$

Where:

A = Cross-sectional area of the canal, m^2

P = length of the wetted perimeter, m .

$$A = D(B + nD)$$

$$P = B + 2D\sqrt{(n^2 + 1)}$$

Where:

D = Depth of water in the canal, m ;

B = Bed width of the canal, m ;

n = coefficient of angle of repose

For example, what design discharge is required for a canal to irrigate an area of 15 ha in the semi-arid subtropics, when the mean daily temperature is $30^\circ C$ and the mean rainfall is 0.20 mm/d during the peak period (mid-season)? The canal is 500 meter long and has to operate for 12 hours per day.

Losses from a similar canal are measured as 48 mm/h with a water-surface width of 1.40 m.

$$ET_o = 7.5 \text{ mm/d; (see Table 1)}$$

Hence, the net irrigation requirement is:

$$I_n = 7.5 - (0.7 \times 0.2) = 7.36 \text{ mm/d.}$$

and, the field irrigation requirement (I_f) is:

$$I_f = I_n / 0.60 = 7.36 / 0.60 = 12.3 \text{ mm/d.}$$

Canal loss = $(W \times S) / (60 \times 60) = (48 \times 1.40) / (60 \times 60) = 0.02$ l/s per meter length.

$$A = 15 \text{ ha} = 15 \times 10,000 = 150,000 \text{ m}^2$$

$$Q = \{(12.3 \times 150,000) / (12 \times 60 \times 60)\} + 500 \times 0.02 = 42.70 + 10 = 52.70 \text{ l/s.}$$

The design discharge of 52.70 l/s should be compared with the water available from the source. If less is available, the area may need to be reduced, or the irrigation time decreased.

19.7 Hydrologic Water Movement

The hydrologic cycle is the cyclic movement of water in its various phases through the atmosphere, to the earth, over and through the land, to the ocean, and back to the atmosphere. The sun is the powerhouse for

the hydrologic cycle, providing the energy for phase changes of water (evaporation and condensation) and for the storage and release of latent heat. Because water is an efficient solvent, all water-soluble elements follow this cycle at least partially. Thus, the hydrologic cycle is the integrating process for the fluxes of water, energy, and the chemical elements throughout the environment.

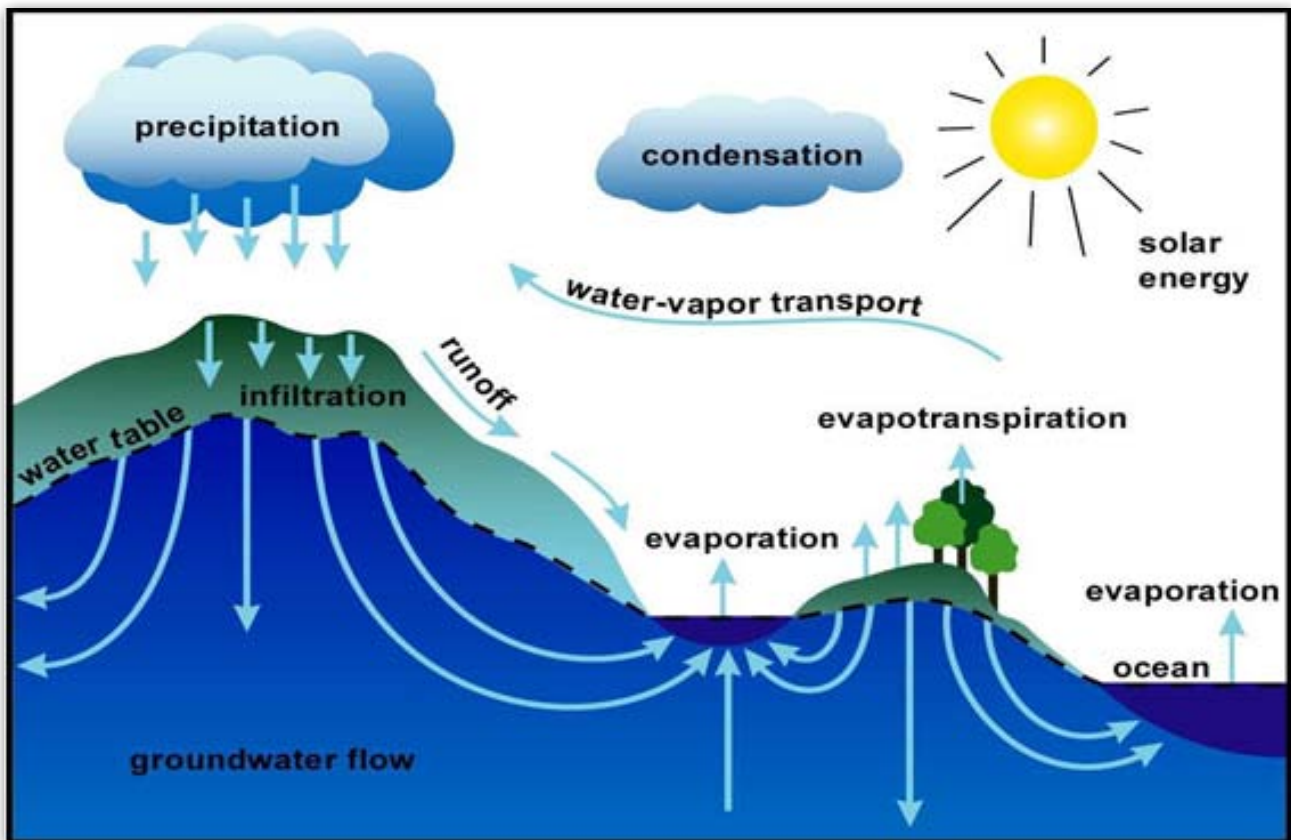

Fig 19.2: Hydrologic cycle of water in different phases

Water enters the hydrologic system as precipitation, primarily in the form of rainfall or snowmelt. It is then delivered to surface waters from runoff or infiltrates into the subsurface. Water can leave the system via stream flow or runoff, evaporation from open bodies of water, or evapotranspiration (evaporation from soil surfaces and transpiration from the soil by plants).

Plants require water for growth and survival and uptake moisture stored between soil particles via their roots. Plant uptake accounts for 15-35% of the total incoming moisture. Nearly all of the water taken up by plant roots eventually is transpired, or returned to the atmosphere.

Different plants exhibit varying abilities to extract water from soil. Through the processes of evaporation, runoff, infiltration, plant uptake, and transpiration, all moisture falling within a watershed as precipitation is accounted for.

19.8 Crop Water Requirements

Transpiration is defined as water entering plant roots and used to build plant tissues or being passed through the leaves of the plant into the atmosphere. Evaporation is defined as water evaporating from the adjacent soils, water surfaces or from the surfaces of the leaves of the plant.

The water need of crops thus consists of transpiration plus evaporation, and is called *evapotranspiration*.

Evapotranspiration is also called crop water need or consumptive use. The water needs of crops are usually expressed in mm/day, mm/month or mm/season.

The crop water need mainly depends on:

1. Climate: in a sunny and hot climate, crops need more water per day than in a cloudy and cool climate.
2. Crop type: crops like rice need more water than crops like beans and wheat.
3. Growth stage: fully grown crops need more water than crops that have just been planted.

Evapotranspiration is also influenced by irrigation practices, length of growing seasons, precipitation and other factors. The crop water need is defined as the depth or amount of water needed to meet the water loss through evapotranspiration. In other words, it is the amount of water needed by various crops to grow optimally.

The crop growing season is divided into four stages:

1. *Initial stage*: germination and early growth stage when the soil surface is not covered by crops.
2. *Crop development stage*: from the end of the initial stage until effective full ground cover.
3. *Mid-season stage*: from effective full ground cover to time of start of maturation.
4. *Late season stage*: from the end of mid-season stage until full maturity or harvest.

The major climatic factors, which influence the crop water needs are:

- ◆ Sunshine
- ◆ Temperature
- ◆ Humidity
- ◆ wind speed

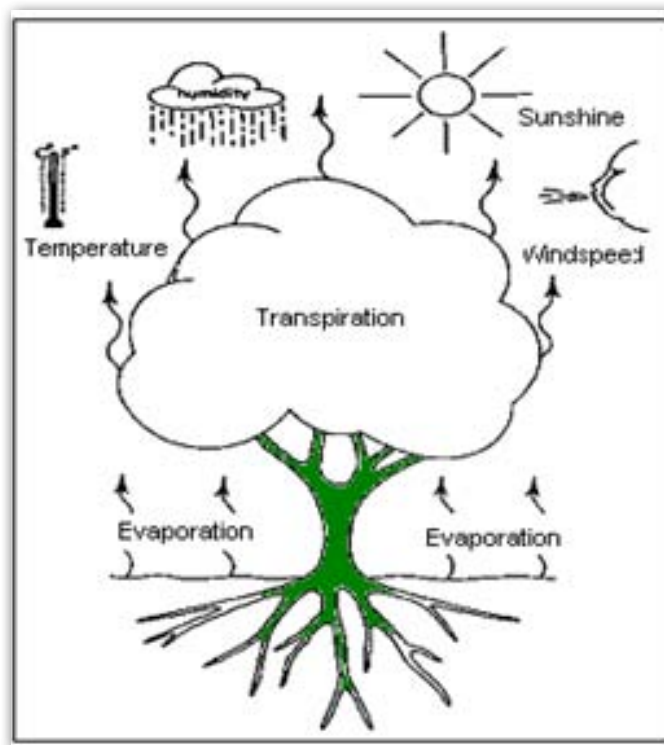

Fig 19.3: Climatic factors influencing evapotranspiration (ET)

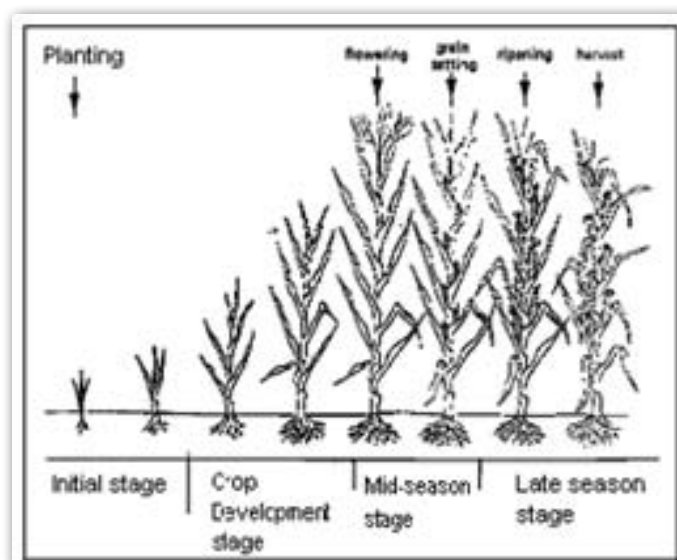

Fig 19.4: Growth stages of crops

The highest crop water needs are thus found in areas, which are hot, dry, windy and sunny. The influence of climate on crop water needs is given by the reference crop evapotranspiration (ET_o).

ET_o is the rate of evapotranspiration from a large area, covered by green grasses, 8 to 15 cm tall, which grows actively, completely shades the ground and which is not short of water. The ET_o is usually expressed in mm per unit of time (mm/day, mm/month, mm/season).

There are several methods to determine the ET_o (Fig 19.5). They are either experimental, using an evaporation pan or theoretical, using measured climatic data (e.g., the Blaney-Criddle method)

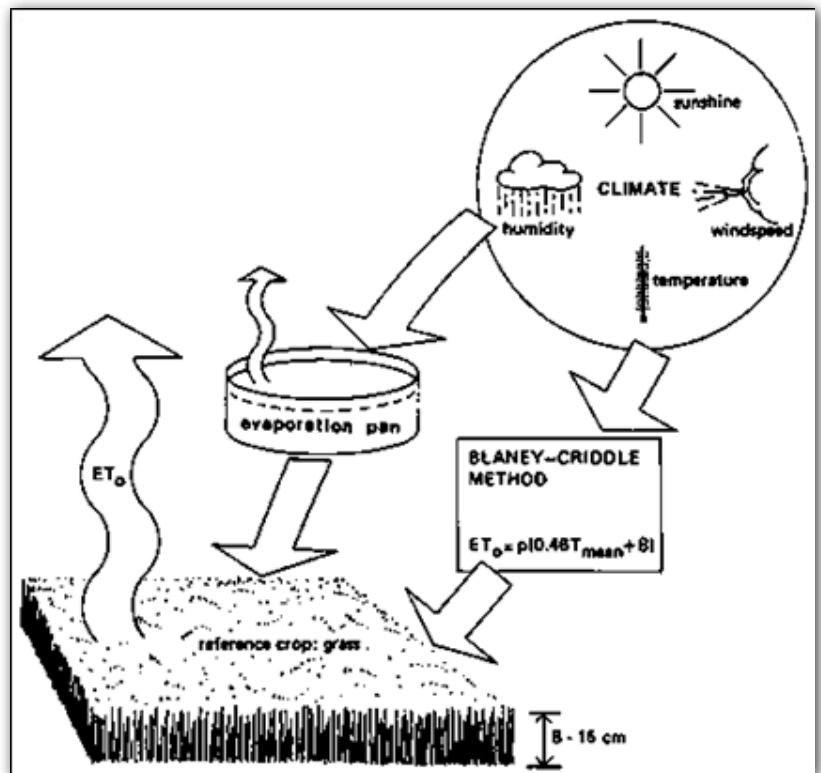

Fig 19.5: Methods to determine reference crop evapotranspiration

19.9 Pan Evaporation Method

Evaporation pan provides a measurement of the combined effect of temperature, humidity, wind speed and sunshine on the reference crop evapotranspiration, ET_o (Fig 19.5).

Many different types of evaporation pans are being used. The best known pans are the class A evaporation pan and sunken Colorado pan (or square pan).

The principle of the evaporation pan is:

- ♣ The pan is installed in the field.
- ♣ The pan is filled with a known quantity of water (the surface area of the pan is known and the water depth is measured).
- ♣ The water is allowed to evaporate during a certain period of time, usually 24 hours. For example, each morning at 7 o'clock a measurement is taken. The rainfall, if any, is measured simultaneously.
- ♣ After 24 hours, the remaining quantity of water, (i.e., water depth) is measured.
 - The amount of evaporation per time unit, the difference between the two measured water depths, is calculated; this is the pan evaporation: E_{pan} (mm/24 hours).

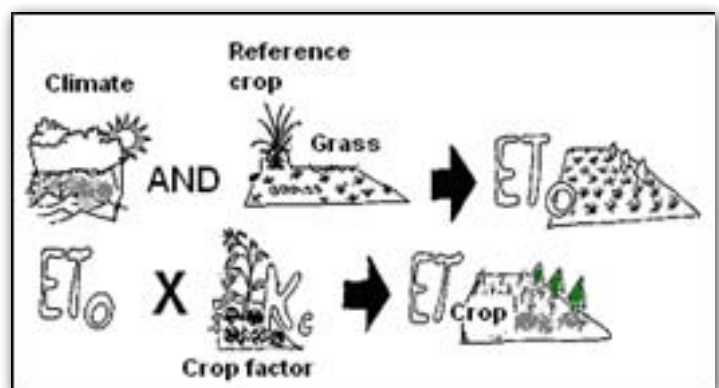

Fig 19.6: Calculation of crop water needs

- The E_{pan} is multiplied by a pan coefficient, K_{pan} , to obtain the ET_o .
 $ET_o = K_{pan} \times E_{pan}$

Where:

ET_o = the reference crop evapotranspiration.

K_{pan} = pan coefficient

E_{pan} = pan evaporation

If the water depth in the pan drops too much, due to lack of rain, water is added and the water depth is measured before and after the water is added (Figures 19.9 and 19.10). If the water level rises too much, due to rain, water is taken out of the pan and the water depths are measured before and after.

Fig 19.8: Adding water when water depth in the pan drops too much

The pan coefficient, K_{pan} depends on:

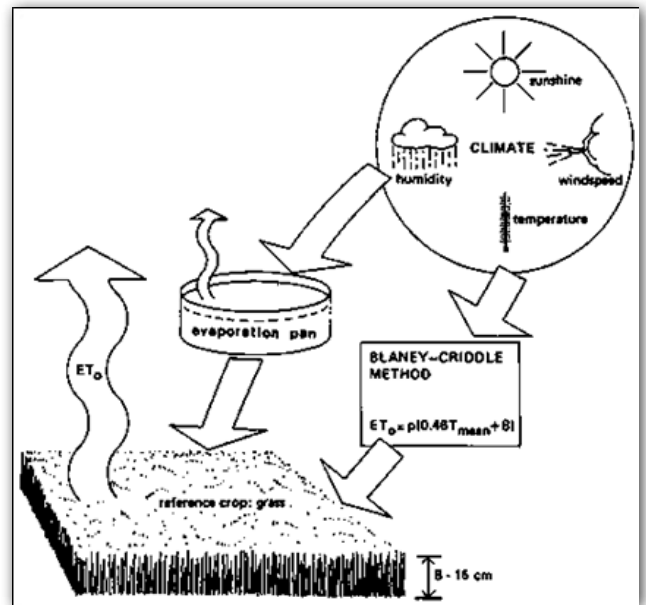

Fig 19.7: Pan Evaporation Method



Fig 19.8: Adding water when water depth in the pan drops too much

- ♦ The pan evaporation (either the pan is placed in a fallow or cropped areas).
- ♦ The climate (the humidity and wind speed)
- ♦ The type of pan used.

For the class A evaporation pan, the K_{pan} varies between 0.45 and 0.85. Average $K_{pan} = 0.70$. For the sunken Colorado pan, the K_{pan} varies between 0.45 and 1.10. Average $K_{pan} = 0.80$.

The K_{pan} is high if:

- * the humidity is high, i.e., humid
- * the wind speed is low.
- * the pan is placed in a fallow area.

The K_{pan} is low if:

- * The pan is placed in a cropped area.

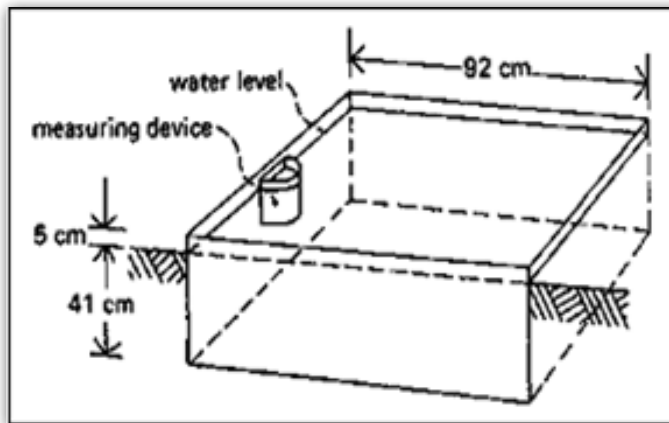

Fig 19.9: Sunken Colorado Evaporation Pan

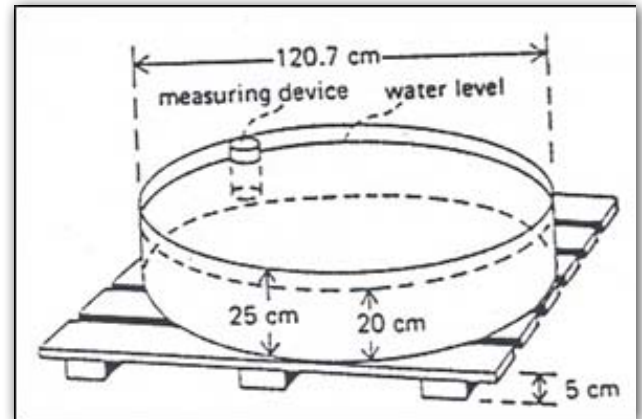

Figure 19.10: Class A Evaporation Pan

- * The humidity is low (i.e., dry).
- * The wind speed is high.

When using evaporation pan to estimate the ET_o , a comparison is made between the evaporation from the water surfaces in the pan and the evaporation of the standard grass. When the water depth rises due to precipitation (rainfall), we have to take out the excess water from the pan. Details of the pan coefficient are provided by the suppliers of the pan. If the pan value/factor is not known the average value could be used.

Examples 1:

1. Type of pan, Class A evaporation pan.
2. Water depth in the pan on day 1 = 150 mm (Fig19.10).
3. Water depth in the pan on day 2 = 144 mm.
4. Rainfall (during 24 hours) = 0 mm.
5. $K_{pan} = 0.75$

Formula: $ET_o = K_{pan} \times E_{pan}$

Calculation: $E_{pan} = 150 - 144 = 6 \text{ mm/day}$

$ET_o = 0.75 \times 6 = 4.5 \text{ mm/day}$

Example 2:

1. Type of pan: Sunken Colorado pan.
2. Water depth in the pan on day 1 = 411 mm.
3. Water depth in the pan on day 2 = 409 mm (after 24 hours).
4. Rainfall (during 24 hours) = 7 mm.
5. $K_{pan} = 0.90$

Formula: $ET_o = K_{pan} \times E_{pan}$

Calculation: $E_{\text{pan}} = 411 - 409 + 7 = 9 \text{ mm/day}$

$ET_o = 0.90 \times 9 = 8.1 \text{ mm/day}$

19.10 Determination of ET_o , Using Pan Evaporation Method

Location: Example

1. Date is 3/4/98; 2. Type of evaporation pan is Class A pan; 3. The month is March.

Note: The difference in water depth between day 1 and day 2 plus the rainfall during day 1 is the E_{pan} for day 1.

- From Table 19.2, Sum $E_{\text{pan}} = 201.60 \text{ mm/month}$.
- Number of days in March = 31.

$E_{\text{pan}} = \text{Sum } E_{\text{pan}} / \text{number of days in month} = 201/31 = 6.5 \text{ mm/day}$.

$K_{\text{pan}} = 0.70$; $ET_o = K_{\text{pan}} \times E_{\text{pan}} = 0.70 \times 6.5 = 4.6 \text{ mm/day}$.

Day	Water depth (mm)	Rainfall (mm)	E (mm)	Day	Water depth (mm)	Rainfall (mm)	E (mm)
1	155.0	-	6.0	17	151.9	19.6	3.9
2	149.0	2.1	5.9	18	167.6	25.4	3.5
3	145.2	3.2	7.6	19	189.5	33.1	3.0
4	140.8	-	7.7	20	219.6/156.1**	14.1	4.2
5	133.1	-	7.4	21	166.0	-	5.8
6	125.7	-	6.8	22	160.2	-	6.7
7	118.9	-	7.7	23	153.5	-	7.4
8	111.2	-	5.9	24	146.1	-	7.6
9	105.3	-	5.9	25	138.5	-	7.3
10	99.4/157.0*	3.6	6.5	26	131.2	-	8.1
11	154.1	-	7.1	27	123.1	-	8.2
12	147.0	-	7.7	28	114.9	-	7.6
13	139.3	-	7.8	29	107.3	-	7.3
14	131.5	-	6.2	30	100.0	12.0	6.1
15	125.3	14.1	6.5	31	105.9	-	7.4
16	132.9	23.8	4.8	1m next month 98.5			

Table 19.2: Measurement of water depth

Note: Measuring devices are usually more accurate than ruler and allow for more accurate readings.

**63.5 mm water has been taken out.

*63.5 mm water was added

1^m The next calendar month.

Chapter 20

Establishment of Nursery

20.1 Summary

At present the need to plant trees on degraded lands and farms is on the increase. It is difficult, however, for smallholders to access at the right time, in the right quantities and high quality trees seedlings that they want to plant. In order to meet present and future demand for planting materials, there is need to promote on-farm and community tree nurseries. Such nurseries can be owned and managed by individual farmers, self-help groups, schools, churches and/or a range of other local institutions. Fruit and tree seedling provide income-generating opportunities, act as models for further nursery development, provide seedlings more cheaply to planters, and can raise the particular species that local people are interested in. The practice describes the various steps involved in the establishment of a tree nursery.

20.2 Description of Establishing a Tree Nursery

Where to site or locate a nursery is an important issue to consider before starting, because it influences the effort that will be required to maintain it, the way which it will be managed, and the ease of access to users. Some of the factors to be considered in selecting the site for a nursery include:

- ♣ a reliable supply of water, ideally being near a river or ponds, or where a water tank or water storage is available;
- ♣ the site should be accessible all year round so that customers are able to get seedlings easily, and nursery staff can manage plants and transport mature seedlings to planting sites;
- ♣ Good soils and other planting materials such as sand should be readily available a site protected from strong winds and livestock; able to receive sun, and should be on a gentle slope to allow drainage.

The size of a nursery depends on many different factors, of which the following are most important:

- ◆ The space available for establishing the nursery. The land available on farms may only be small in area, but more space may be available in public land like school yards or church grounds;
- ◆ Whether the seedlings are grown in pots or in beds, and whether they will be raised from seed or from grafts, or from bare rooted cuttings, etc. This will influence the amount of space each plant needs. Remember that in a nursery additional space is required for keeping collected soil, sand and manure, and for mixing these materials;
- ◆ The numbers of seedlings to be raised for personal use and for sale- when considering the size of the market for seedlings, it is better to start by being conservative in estimating what your market will be; and
- ◆ The amount of water that is available to maintain seedlings.

When establishing a nursery, it is important to have somewhere to keep nursery tools safely and in good condition. This does not have to be at the nursery itself, but could be in the house, school, church or other location. The basic and useful tools needed for a nursery operation include shovels, watering can, wheelbarrows, pruning knives, knife sharpeners, soil sieves, and rakes.



Fig 20.1: Integrated seedling nursery management

20.3 Nursery Site Preparation

The time to start work in the nursery depends on when field planting is planned. It is important to allow sufficient time for seedlings to grow to a size where they will survive well when transplanted in the field (normally 30 to 45 cm, though this depends on the species, where seedlings will be planted in degraded and/or farmlands, and how they will be managed). The initial labour needed to establish a nursery includes: bed construction, soil collection, fencing, the procurement of tools, etc. can take considerable effort. It can be done some time in advance - before raising seedlings. The sourcing of seeds or rootstocks that will be used to establish nursery plants (see Fig 20.1) will also often need to be done in advance.

The soil used to raise seedlings should be fertile and should drain well. Once a suitable collection site has been identified, clear the surface of weeds, leaves and other litter, then dig out the topsoil to a depth of about 10 cm. Remove any stones and roots, ideally by sieving. Mix 2 parts of soil with 1 part of manure or compost and 1 part of sand (if available).

20.4 Nursery Operations

Tree nursery operations involve various activities such as seed sourcing, seed bed preparation, sowing seeds, potting, pricking out, shading, watering, weeding, root pruning, and application of additional fertilizers or manure.

It is important to try and use good quality seed in planting. Seed can be collected from trees locally, farms, forest or public land, as long as one collects from at least more the 30 trees. and purchase from suppliers. It is a good idea to collect seed with neighbours; then bulk this seed together and share it out. In this way, diversity is maintained in planted material, which is important in promoting good performance.

When getting seed from a supplier, it is important to look at the seed and check that it appears to be of good quality, and hasn't been collected too early (is immature) or contains many empty seeds. Before planting a lot of seed, it is a good idea to first check its viability by seeing if it germinates well. Once you have an idea about viability, then it will be possible to estimate how many seeds need to be planted to get a certain number of trees (for example, how many seeds to plant in an individual pot). Seeds can be bought from local seed dealers, NGOs, and institutions such as forest departments. More information on how to source seeds can be obtained by getting in contact with your local seed center, or by reading resources like ICRAF's Tree Seeds for Farmers Toolkit.

Sometimes it is important to treat seeds before they are planted in order to improve on the level, speed and uniformity of germination. These seed pre-treatment methods can be used when seeds do not otherwise germinate well. The most common methods for seed pre-treatment are:

- a) **Soaking seed in hot water until the seeds look swollen:** This is used for seeds of trees such as most acacias, leucaena, albizia and calliandra. In seed soaking method, water is boiled and poured over seeds in a container. In this case, allow to cool and leave the seed in the water until the seeds look swollen.
- b) **Soaking seed in cold water:** This method is recommended for seeds that have soft seed coats such as sesbania, tephrosia, dalbergia species, gmelina, gliricidia, and acacia augustissima, etc. The time for soaking varies between 12-48 hours, depending on the tree species. The procedures are: (1) soak the seeds in cold water which is 2 times its volume, (2) remove all floating seeds, and (3) sow the remaining seeds at the bottom in containers in the nursery or sow directly in the field after cracking the seed shell method. This method is used for tree species with a hard coat like melia (mukau), podo species, croton megalocarpus, etc. The cracking is done to allow water penetration for easy germination and it is done by using a sharp knife, a stone or a cracking machine
- c) **Nicking:** -cut slightly the seed at one tip to allow water penetrate. Seeds such as Croton megalocarpus, neem, cassia spp. and kei apple can be sown directly into the container. Fine and light seeds such as Eucalyptus, Casuarina are sown in transplant beds and later pricked out into containers. It is important that fine seed is mixed with sand and uniformly broadcast on the seedbed to avoid overcrowding that can lead to dampingoff.

Do not sow the seed too deep in the soil. The depth of holes should depend on the size of the seeds (usually 5 mm to 1 cm). Sowing too deep is likely to prolong seed germination period or seeds may die or rot. Put a seed in each hole, and gently cover with soil equal to the size of the seed itself, and water the pots. Make a light shade with grass to cover the pots or the seed bed after sowing. Water the sown seeds twice a day (early in the morning before 9.00 am and in the evening after 4.00 p.m) If this is not possible then water the seeds in the evening only since most of the water at this time is taken-up by the plant as there is very little evaporation loss.

20.5 Seed Bed Preparation

Nursery beds can be arranged in different ways. Potted seedlings can be raised on a flat bed, or can be set into a sunken bed, which is a basin like excavation of about one meter by one meter and about 10 cm deep. Such a structure holds seedlings together, and helps to conserve water in dry areas. Raised beds are used for establishing bare-rooted seedlings as the sides of the bed can be broken down to reveal the roots of plants, ready for transplanting. Staking slats of wood into the ground in a square or rectangular shape, with sides of about one meter and then filling this structure with soil (mixed with sand if possible) makes a raised bed.

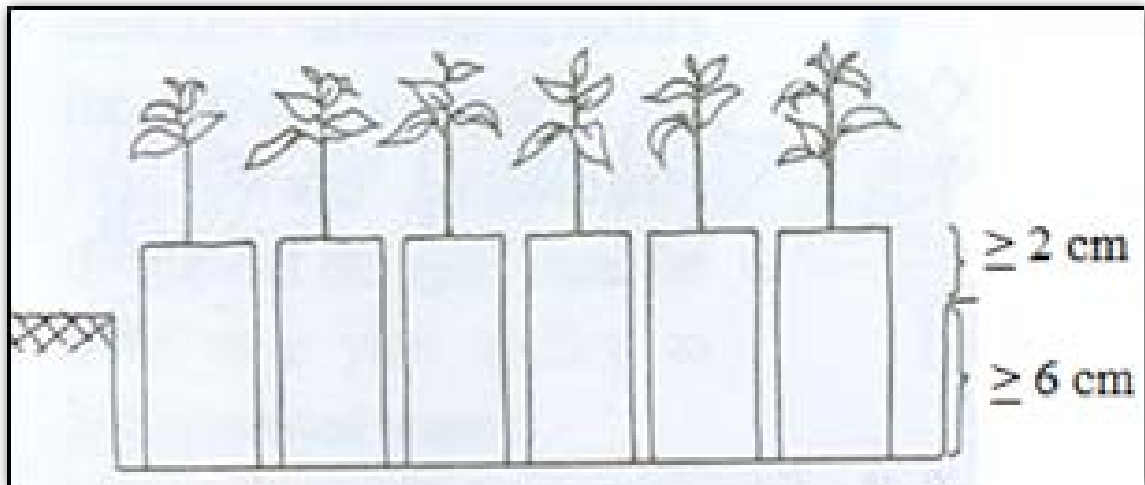

Fig 20.2: Potted seedling production

Alternatively, the sides can be made from bricks or the like. It is normal to germinate small seeds such as eucalyptus, sesbania or cypress in such seedbeds, to allow them to germinate before transferring small seedlings to pots or planting them directly.



Fig 20.3: An example of a sunken bed filling made from raised bed bricks with a mix of soil and manure

In this regard, the amount of seeds required to be produced in a nursery for a given area can be calculated by using the following formula:

Seed amount required
 $=125 \times N / PW \times (1 + E/100)$

Where;

N = Number of seedlings required for planting;

p = germination rate;

W = Number of seeds per kg;

E= an extra quantity required if some of the seeds are not good.

125 is correction factor to add a 25% reserve.

Calculation of seeds requirement:

Given:

- ♣ Species A targeted to plant 30 ha with a planting density of 2,500 seedlings/ha (total number of seedlings/plants required, $N = 30 \times 2,500 = 75,000$ seedlings),
- ♣ Germination rate (p) = 30%,
- ♣ Number of seeds per kg (W) = 70,000
- ♣ 10% will get damaged during storage (E) = 10%

Calculate the amount of seeds required to plant 30 ha of land, including 25% reserve.

$$\begin{aligned} \text{Amount of seeds required} &= 125 * \frac{N}{PW} * \left(1 + \frac{E}{100}\right) = \\ &= 125 * \frac{75000}{30 * 70000} * \left(1 + \frac{10}{100}\right) = 4.911 \text{ kg, which is approximately 5 kg.} \end{aligned}$$

1. Potting

Potting mixture (soil, sand and compost/manure) should be moistened and then pressed into containers to a depth of about three-quarters of the height of pots. Pots should then be topped up more loosely with the mixture and pressed down lightly to about 2 cm below the top.

Heavy compaction should be avoided at the top of pots because it will inhibit root penetration. Before planting seed, containers should be watered lightly. Sometimes, more than one seed can be planted in a pot. If more than one seed germinate, seedlings can be removed to leave a single individual. This approach might be used if the germination rate is expected to be considerably low.

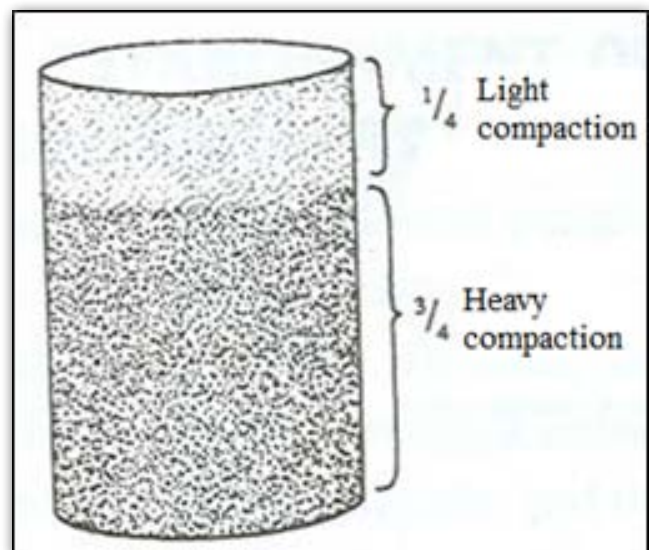

2. Sowing Seed

When raising seedlings in pots it is normal to use polythene tubes that are around 10 cm in diameter and 20 cm deep, though the size of pots will depend on the species in question and the time that seedlings will be in the nursery.

Apart from using plastic tubes, other locally available materials that can be used include small tins, milk packets, cardboard boxes, banana fibre containers, calabashes and clay pots. It is better to use open-bottomed than closed containers, since this allows healthier root development and possible root pruning. If tins or other containers are being used, it is important that holes are made in the bottom to allow the movement of water.

Seed sowing time depends on the species and the time it takes to attain size for planting out (30-45 cm). It is important that the seeds are sown in time to enable the seedlings attain the recommended size (at least 30-45 cm tall).



Fig 20.4: Cover the nursery with dry grass or maize stalk then water

This should be attained before the onset of rains

3. Sowing Seeds in a Seedbed

Draw lines 10 cm apart or the width of your palm; sow at the spacing of 10 cm between seeds. Cover the nursery with dry grass or maize stalk then water.

4. Pricking Out Process

This is the process of transferring young and tender seedlings from seedbeds into containers (pots). Pricking out should be carried out when the seedlings reach a height of 2 cm. This is usually about two weeks after sowing but depends on the species. Pricking process includes the following procedures:

- ♣ Water the seedbed and containers properly before commencing the operation;
- ♣ Ensure adequate shade is available;
- ♣ Take an empty container and fill with water to $\frac{3}{4}$ level;
- ♣ Hold the leaves of the seedlings and insert a pencil thick stick (dibble) underneath the root system to loosen the soil;
- ♣ Pull out the seedlings gently and immediately put them in the container with water. Note that if the roots of the seedlings are kept under sunshine they lose water and may die;
- ♣ Make a hole at the center of the pot using a stick;
- ♣ If the roots are too long clip off the tip;

- ♣ Do not hold the stem of the seedling because they are tender and feeble – this may injure the seedlings;
- ♣ Hold the stick in a tilting position and insert it in the soil, about one centimeter away from the seedling to the same depth as the hole;
- ♣ Push the soil towards the seedling to hold it tightly. This ensures that all the air pockets around the roots are closed;
- ♣ Using your fingers cover the hole you made;
- ♣ Water the containers properly once more after planting. Seedlings pricked out from the same batch of the seed bed should be arranged in the same place.

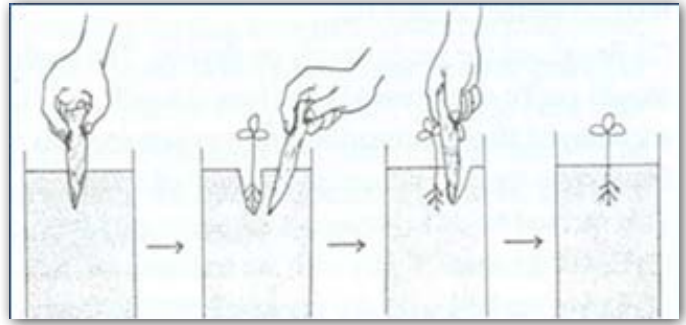

Fig 20.5: Transferring/pricking young & tender seedlings from seedbeds into containers (pots)

5. Shading

Construct a shade to protect the seedlings from direct sunlight for two to three weeks after pricking out. Use locally available materials such as grass, mats, or banana fibres for shade construction.

6. Watering

The regular supply of clean water is essential to plant growth. Plants are made out of more than 90% water. When grown in containers, nursery plants have only a limited volume of substrate and do not have the ability of mature trees to search for water from below the soil surface. The amount of water seedlings require depends upon:

- **Seedling age.** More water is required after germination when the seedling is young and at pricking out but this requirement reduces as the seedling grows in age. The amount of water should be reduced four weeks before the seedlings are planted out. At that stage, the soil can be left to dry out completely and the plants to wilt for a day. The process should be repeated several times.
- **Amount of sunlight.** If the area is sunny, more water is needed and vice versa. However, do not keep the area shady for too long to with a wrong intention to reduce water use.

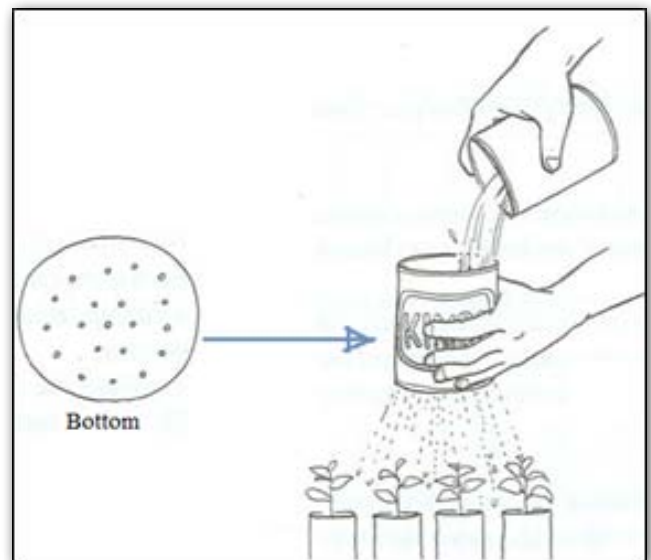

Fig 20.6: Watering using a simple tin with holes at the bottom

- **Soil type.** A sandy soil loses water faster than a soil with high clay content hence the need for more frequent watering. However, a clayish soil becomes hard and cracks if it dries out. The substrate should be watered thoroughly so that the water is directed to the soil and not the leaves except to dust the soil lightly. A watering can or a hosepipe with a nozzle should be used to ensure uniform distribution of water. The whole bed should be watered and not just the plants in the center of the bed.

Low water pressure is good but one should ensure that water gets to the bottom of the container to avoid a dry and hard bottom, which will affect the growth of the roots as they get to the bottom of the container. Water should be clean to ensure seedling health. Water from such sources as kitchen waste should not be used.

Too much water can damage the plants just as inadequate water because of water logging which prevents roots from breathing. Avoid direct use of hosepipes while watering the seedlings as this may wash away the soil. It is preferable to use a watering can or an empty tin with holes at the bottom.

This is used to reduce the power of water drops which cause soil erosion and helps to distribute water evenly. As already mentioned, watering should, in principle, be done twice a day early in the morning and late in the afternoon after 4.00 pm. when the sun is not strong. If this is not possible, then water once a day in the evening. During rainy seasons, watering may be done once or not at all. Avoid under-watering and over watering. Use adequate amount of water; for example, 20 litres for 1,000 seedlings.

7. Weeding

Weeds are a threat to healthy seedlings development. They compete with seedlings for nutrients, water and light hence they must be controlled. With your hands or a dibble gentle pull out unwanted growth (rouging). This should be done whenever weeds are observed. Remove all the weeds around the beds with a jembe and don't leave any rubbish around unless you are sure that this can be converted to compost.

8. Root Pruning

Root-pruning is the cutting of roots to control root system development beyond the container when seedlings have reached to a certain size and their roots become longer than the depth of the pots. If the roots are left without pruning, they penetrate into the ground and develop the root systems there. Once the root system develops under the ground, it is hard to move the pots, and if the roots are cut when the seedling is old, the seedlings will be weakened. Therefore periodical root pruning is required before the root system enters into the ground. The period and interval of pruning depends on different species and other conditions.



Fig 20.7: Root pruning using a knife

Root pruning should be done regularly, preferably every 2 to 3 weeks. Prune when seedlings are equal to the height of the span of your palm and when their roots have started to penetrate into the under surface. When pruning the roots:

- ◆ Water the seedlings properly before root pruning.
- ◆ Using a sharp knife or wire or scissors, cut the long roots underneath the container. You can also lift up the containers (wrenching) to cut overgrown roots.
- ◆ Water the seedlings well after root pruning. This helps the plant withstand moisture stress.
- ◆ Note that to reduce root pruning, you can place the seedlings on a bed of stones or on polythene sheet and this reduces root development.
- ◆ If the seedlings are in a raised bed, prune the roots by using a panga, knife or wire underneath the bed, soon after watering (see Fig 20.7).

9. Hardening off Seedlings

Hardening up is to expose the seedlings to harsh conditions to make them strong so that they will be able to survive under a harsh climate in the field after planting out. It is also a gradual preparation of seedlings for field conditions. The hardening up includes the following processes:

- ◆ When the seedlings grow and reach the planting size, the shade should be removed to expose the seedlings to more sunshine.
- ◆ Reduction in watering intensity (quantity) and frequency - water twice a week and later once a week.
- ◆ Before planting out, root pruning should be carried out frequently or re-arrangement of pots to allow more adoption to stress.
- ◆ Good preparation for out-planting results in good field survival rate. Hardening off should therefore be done 2 to 3 weeks before out-planting time.

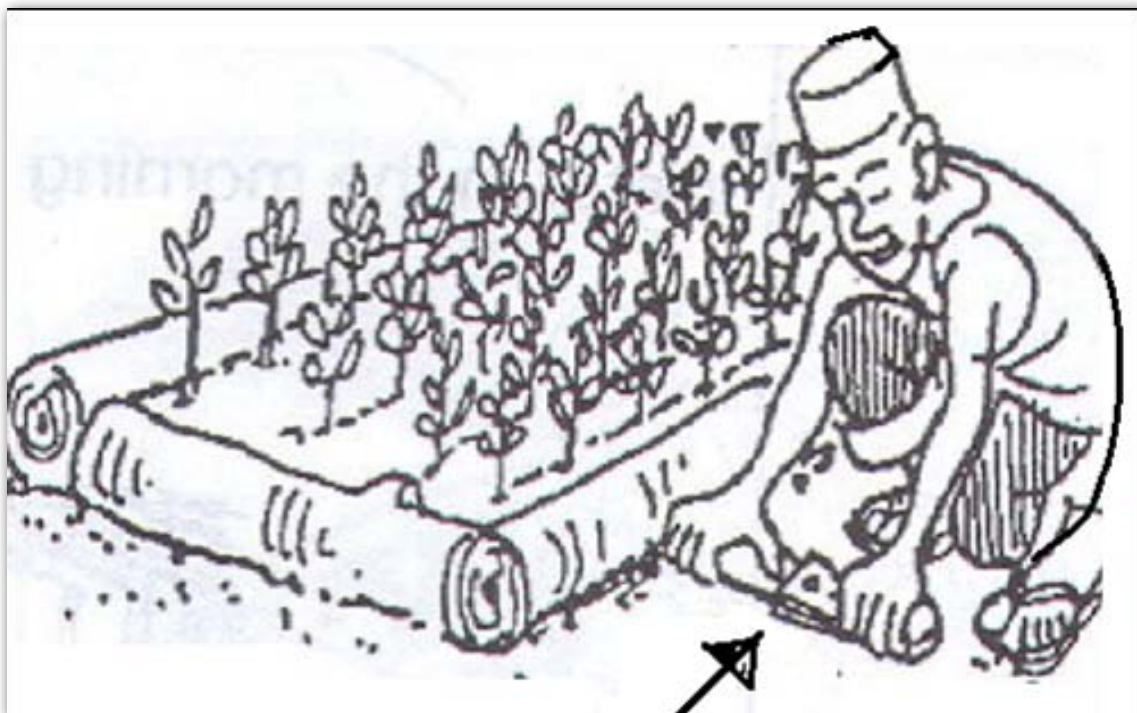

Fig 20.8: Hardening off seedlings

10. Postponing Planting

If it is not possible to plant when the seedlings are ready for planting out (reached right size for planting - at least 1.5 ft tall) or the seedlings are not bought, cut the tips of the plant to suppress further growth so that they will not be overgrown during next planting season.

11. Seedling Protection

Seedlings are delicate and susceptible to attack by various pests and diseases as well as weather conditions. Such damages can seriously weaken or kill the seedlings. It is important that the damages be dealt with immediately. Damage in the nursery may be categorized as below:

- a. **Weather conditions:** This is damage caused by adverse weather conditions. We can either regulate watering or shading to comply with prevailing weather conditions.
- b. **Human:** This is the stealing and/or intentional damaging of seedlings by human beings. Fencing and security are the options to overcome this.
- c. **Livestock and wild animals:** Livestock and wild animals browse or graze on seedlings. Fencing can prevent this. Rodents or field mice/rats frequently cause serious damage to seedlings in the nursery as well as in the field by eating them. To control these, cleaning the nursery helps to reduce their population.
- d. **Insects:** Termites are the most common recorded insects in the nursery. They eat the roots and stems of many tree species. Eucalyptus is particularly susceptible to termite attack.

Termites may be controlled by several methods such as:

- Putting a thin layer of ash (2-3 cm thickness) on the bed, where the pots or tubes of seedlings will be placed. However periodic application is required since ash cannot be effective for long;
- Digging out the queen from nearby colonies (termite hills), use of plant extracts and chemicals in severe cases;
- Using chemicals such as Dieldrin and Aldrin;
- If milk packs are used as pots, wash the packs with soap water or solution of insecticide before use, otherwise termites may be attracted to the seedlings.

12. Field Planting Out

A lot of trees have been planted over the years, for example, in farms or public areas but only a few survive. This is due to poor knowledge about proper timing, technical aspects on proper tree planting and tending techniques. It is important to note that healthy seedlings cannot grow well or survive if not planted properly. Natural regeneration of trees grow without any care but their survival rate is generally very low and unstable.

This section is developed to enable farmers, extension agents and tree nursery operators to get guidance in proper tree planting and tending techniques for high survival rate. It is important to ensure that seedlings to be planted are big enough (at least 1.5 ft high). Always remember to plant as soon as possible after you get the seedling from the nursery. Do not plant trees too close to buildings and installations such as power (electricity) lines, water pipes or telephone posts. Water the seedlings just before transporting them from the nursery to the planting site to protect seedlings from drying up during the transportation.

Note: It is better to plant your seedlings when it has rained for at least two weeks or when the soil is really soaked with water (if water penetration has reached a certain depth of 30 cm from the surface), so that even if no more rain is available the plant can take off. Plants grow well if the soil is soaked before planting or if the rain continues for two weeks after planting.

a. Spacing

Plants may be spaced at 3m by 3m, or 5m by 5m, or 6m by 6m, or 8m by 8m, or 10m by 10m (larger spacing is used for indigenous species or fruit tree species like mangoes since these require large spacing). For hedges, the spacing can be 15cm between the plants or 30 cm between plants in a line to allow the fence to grow faster.

b. Digging Holes

Planting holes should be dug before rainy season commences if possible since water collects in it and makes the survival easy even when rain is inadequate. Dig a hole 30 cm x 30 cm (the distance from your wrist to your elbow), or 45 cm x 45 cm, or 60 cm x 60 cm (especially in dry areas). The size of the hole will however depend on the size of the seedling. The purpose of a planting hole is to soften the soil so that the roots of the tree can easily penetrate and the loose soil can catch and contain more moisture.

c. Planting Process

Water the seedlings before transporting them from the nursery to the planting site. This watering is to protect the seedlings from drying up during the transportation. When transporting seedlings do not pile them up on each other. Using boxes or bags is recommended if the planting site is far. Always carry the seedlings upright. Transferring seedlings from the nursery to the field needs great care to avoid damaging them. If the seedlings were raised in polythene tubes or tins:

- ♣ Prepare a box or sack
- ♣ Choose strong seedlings
- ♣ Pack the seedlings by arranging them neatly, ready to transfer them to the field
- ♣ If seedlings are ready to plant, re-fill one-fourth of the holes with wet top soil around the holes or with the soil removed when preparing the holes.
- ♣ Remove the polythene bag or tube by tearing it while holding the seedling up-right.
- ♣ If the seedlings were raised in tins or any other type of containers, bang them from the top slightly.
- ♣ Remove the seedlings from the tubes with their soil by holding them under the stem.
- ♣ Put the seedlings in the holes and cover them with the top soil and then the sub-soil.
- ♣ Place the seedlings in the hole without removing the pot soil or bending roots.
- ♣ Press down the soil nicely.
- ♣ Fill the holes with top soil from the forest or the best soil you have nearby (from trees in the farm or collected around the banana base). If possible, the soil can be mixed with manure to provide the plant with more nutrition.
- ♣ Use your hands to firm the soil carefully around the roots.
- ♣ Make sure the seedlings sit on the ground at the same level they sat in the containers or nursery.
- ♣ When the hole is filled, tread gently with your feet to make the soil firm. Make the firm soil into the shape of a pit or basin so that it catches rain-water and holds the water when you water.

- ♣ Water the seedlings immediately after planting if the rain is inadequate. If you plant in dry season, water two times a day - early morning and later in the evenings; or at least once but in the evenings.
- ♣ If the plant is not safe, build a fence of sticks or thorns around the seedling to protect the plant from animals (goats, sheep) and children.
- ♣ If a tree seedling seems too weak or not very straight and needs support, place a strong stick in the ground close to the seedling and tie a piece of old plastic wrapper between the stick and the seedling.

13. Mulching

After planting, cover the soil surface with some materials (dry grass/leaves/twigs) to avoid evaporation or to help the plant retain water. This technique is called mulching. Note that small stones can also be used as covering material.

14 Water Harvesting

To utilize rain water effectively, several types of micro-catchments are used to harvest the surface water effectively and to provide enough moisture to the seedlings.

- ◆ V-shaped shallow trenches are dug to conduct the rain water to the planting holes.
- ◆ When rainfall is very scarce, use divisions of the surface water. In this case, the ground is divided by ridges and all the rain water is directed/collected towards the plants.

Chapter 21

Closed Area Management

21.1 Introduction

Rehabilitation of degraded land often involves excluding livestock and human interference from degraded sites. The main objective of area closure is to allow native vegetation to regenerate as a way to reduce soil erosion, increase rain water infiltration and provide fodder and woody biomass. To safeguard and restore degraded lands and deteriorating forests, area enclosure and management is a very critical phenomenon to be considered. In many areas of Uganda, closed area management strategies are ecologically and socially sound procedures where natural resources management and rehabilitation measures are basic to meet the requirements to restore the diminishing and dwindling ecosystem balances. Area enclosure limits nutrient losses from sites by controlling runoff water through vegetation by acting as a physical barrier to soil erosion.

Degraded area enclosure also improves the capability of the land to support other vegetation types and biomass improvement including exotic plantations enrichment, and feed-growing to support livestock development. The fundamental purpose of area enclosure and management is to maintain economically productive and biologically diverse vegetation production in open and degraded lands that are affected by severe land degradation. The practice of area enclosure has been successful in many degraded areas of arid and semi-arid areas that is similar in many areas of Uganda where the precious natural resource is subject to critical land degradation problems. This practice will help change the marginal lands to potentially productive lands that can provide important biomass improvement and vegetation assets. The method of degraded area enclosure plays an important role in conserving the remaining soil resources and improving soil fertility. These can become sources of income, wood for construction, farm implements, non-timber forest products, etc.

21.2 Definition of Closed Area Management

Closed area management is a method for degraded land rehabilitation by protecting an area from interference for a limited period of time, depending on the capacity of the site for vegetation re-establishment and rehabilitation. Closed area management is typically selected for natural regeneration. These are normally degraded areas with shallow soils in which the natural vegetation is a means of land rehabilitation. The main objective of closed area management is the rehabilitation of the degraded areas. Because the fundamental purpose of most closed area management is for rehabilitation, the technique is usually applied in steep, eroded and degraded sub-watersheds. Closed area management is one of the options for regeneration of degraded lands and is cheap as compared to establishing plantation on the same sites and it requires low technical expertise to rehabilitate and use.

21.3 Principles of Closed Area Management

Regardless of the land holding type and tenure, the participation of the local community and equitable benefit sharing is the key to the successful closed area management. The participation of the local community should include empowering them in decision-making and mobilizing their capacities to manage resources, and controlling activities that affect their lives and livelihoods.

The primary purpose of local community participation in closed area management activities is to make the user communities feel that the closed area can generate optimal economic benefits for them and improve the ecosystem balance.

Closed area management is a special technique used for selected sub-watersheds where livestock and human interference is prohibited. These closed areas are mainly located on less fertile sites and degraded lands with a significant exposure to soil erosion and deforestation. Degraded areas are mainly closed to improve wood and grass production (biomass). The size of closed area may vary between 10 and 200 ha and bigger area closure is not common and effective for management purpose (Forster, 2002).

In order to conserve the productivity of the vegetation in closed areas or sub-watersheds, it is necessary to develop management plans for these areas. Management plans should propose appropriate restoration and treatment measures for closed areas, such as soil and water conservation and management, tree planting and biomass utilization, etc. In this regard, the land users can get the highest possible yield and benefits while preserving the ecosystem and its sustainability.

Several of the proposed steps and methods of area closure and management are not necessary to get a sound and reliable database for closed area management. It is, however, recommended to standardize the assessment and planning methods and to concentrate on the essential management principles and aspects wherever possible. When developing the management plan, more emphasis should be put on the active participation and sense of ownership of the individuals and local communities.

While developing the management plan for area closure, the main activities to be considered include:

- ◆ Identification of areas to be closed.
- ◆ Defining the closed area management principles.
- ◆ Defining the important considerations in closing the area and its management plan.
- ◆ Defining the objectives of the management plan.
- ◆ Defining the main elements and components of management plans.
- ◆ Defining the steps that are necessary to develop a management plan.
- ◆ Defining the data required in order to set up a reliable management plan and local bylaws and regulations.
- ◆ Proposing the method of data collection required, the information level as well as consideration of costs involved.
- ◆ Clear guidance on participation and the role of relevant stakeholders in the development of the closed area management plan.

When developing a management plan for area closure, it is not only necessary to take into account the vegetation production and soil conservation aspects but also all possible factors that may have an impact on the management of the site concerned. Relevant framework conditions such as social, legislative, economic, infrastructures support aspects and the neighbouring production system should be considered. In addition, the soil and water conservation as well as biomass production aspects should be analysed in the context of the relevant area closure and management. The highest priority has to be given to the needs and requests of the intended individuals and user communities.

All stakeholders, particularly the district offices and sub-county planners have to be aware of the closed area management. This is not an end in itself. It has to serve the needs and interests of the local community and every management plan has to be considered from that viewpoint.

Therefore, it is very important to involve the local community and get their full assurance when developing closed area management plans. The management plan should also be designed by ensuring the best possible proposal for the treatment and efficient use of the assets from the closed area. Thus, based on the concepts and principles of protection, management and sustainable utilization, the management plan should be produced in line with the general management plan and guideline for closed area management. In fact, the closed area management plan should be a tool to balance the ecological and economic benefits, but it should never be an access to legalize over exploitation of the closed area.

The closed area management plans should contain guidelines and prescriptions for the medium and long-term management plan in order to achieve the intended objectives. The appropriate closed area management plan has to take into account the different and specific considerations, such as the socio-economic, ecological, vegetation and topographic conditions, interest of the individuals and communities; local bylaws and regulation; general management principles; and overall development policies.

The areas to be closed may include those:

- ♣ prone to critical resource degradation.
- ♣ highly vulnerable to runoff and soil erosion including landslide.
- ♣ partially or totally devoid of woody vegetation and left with no soil.
- ♣ with fragile soils, poor vegetation cover and demanding for re-vegetation.
- ♣ or sub-watersheds prone to hazards for gully formation
- ♣ generating severe siltation and causing damage to down streamsslopes.

In general, the areas that have to be closed and managed are those that have lost effective soil depth and plant cover due to past and present severe erosion problems. They should be classified as areas prone to severe land degradation and accelerated losses of soil. The restoration of vegetation of a closed area is capable of trapping a high amount of sediments, although not everything that is released by the source area. It is, therefore, the first main task of the responsible management planners and soil and water conservation experts to analyse and identify areas that are prone to severe soil and water erosion. Often steep slopes, gully areas, ravines, fragile soils with poor vegetation covers are prone to severe land degradation problems. Therefore, the sub-watershed has to be demarcated and delineated for implementation of appropriate conservation and enrichment plantation measures.

21.4 Approaches to develop Closed Area management plan

The management plan for area closure has to be developed in close co-operation with all stakeholders, particularly the land owners, intended potential beneficiaries, and other parties involved. In the process of area closure, the local community should be involved in the demarcation and delineation of areas to be closed. From inception, soil and water conservation extension workers, the community development committee, and sub-county officials identify the sub-watershed for protection based on agreed physical criteria. The final selection of the sub-watersheds will be made during a general meeting of all community members. Methods of protection and management should be decided on by the entire community based on the interests and agreements of the entire community membership.

21.5 Useful procedures in closed Area Management

The useful and important procedures and criteria in closing a sub-watershed subject to severe land degradation include:

- ◆ Providing necessary information about stakeholders.
- ◆ Assuring the general objective of the area closure
- ◆ ensuring the role of individuals and communities in the planning process
- ◆ Explaining in detail the information that is required for the management plans in accordance with the local bylaws and present guidelines.
- ◆ Collecting and studying the relevant documents and giving information to relevant stakeholders
- ◆ Carrying out the necessary survey of the sub-watershed to be closed.
- ◆ Initiating and establishing a communication process among the stakeholders to develop ideas and proposals concerning the specific management objectives and options.
- ◆ Facilitating decision-making processes concerning the proposal for area closure.
- ◆ Involving all stakeholders in all relevant meetings when it is required.
- ◆ Discussing the management proposals with all stakeholders and amending them according to the resolutions of the responsible decision making body.
- ◆ Ensuring that all decisions are the right obligations of the communities as to defining their management objectives and proposing ways and means as to who is responsible to achieve them.

The soil and water conservation extension worker and sub-county planner should be able to facilitate the communication between different stakeholders. All the participants should be informed about the bylaws and regulations. In addition, the soil and water conservation extension worker and sub-county planner should facilitate the development of ideas among the stakeholders and guide the decision-making processes in a participatory manner.

Provisional Work Norms and Technical Specifications for Labour Intensive Public Works

22.1 Descriptions

This summary of professional work norms and technical specifications for labour intensive public works (LIPWs) may be revised and adjusted through further practical field testing and findings. Since most of these provisional work norms and technical specifications have to be identified and adjusted during the implementation processes of LIPWs relevant to the local contexts of the agro-ecological area, the summary presented here is not meant to be sufficient to fully envision the purposes of the work norms and technical specifications for the entire techniques and technologies that may enable possible modification. However, it is adequate reference and will be supported by further testing and technical references that would be applicable and customized to Ugandan conditions.

Technical specifications and provisional work norms for some emerging LIPWs, which are not yet captured in this manual, and yet potentially useful under Ugandan conditions will be identified and discussed through time based on their technical standard requirements. These LIPWs which appear to play an essential role in supplementing and supporting implementation of public work programmes, will be implemented in specific agro-ecological conditions.

The rationale for these technical specifications and provisional work norms for LIPWs are therefore to accommodate better technical standards for better performance and provide for the quality of LIPWs. Implementation of better quality LIPWs is to be as fair as possible for the labour requirement of subprojects and accommodate a broader range of design adaptation to difficult agro-ecological conditions, ranging from moisture-stress to moisture-abundant areas, by reducing maintenance costs. However, the specifications and provisional work norms for the current list of LIPWs will have to be reviewed within an acceptable range of time to reflect innovative thinking and experience. The LIPWs for which these technologies have been prepared include, but not limited to, storm water drains, gully check dams, terraces, cutoff drains, waterways, farm ponds, micro-basins, trenches, flood control measures, community roads, etc.

While developing this technical design manual, minimum technical standards and basic requirements related to design specification have been assumed to be met for each LIPW project. In this regard, this technical specification is considered to provide minimum technical information that is necessary to fulfill the basic design requirements of LIPWs.

For any additional information and further details, experts, field supervisors and technical field staff are advised to refer to other specifications, technical manuals and design standards developed for different LIPWs. This summary information on specifications and provisional work norms for different LIPWs indicated in the following matrix has been adapted and developed for activities implemented for many years in natural resources management in Ethiopia and elsewhere which have been revised and adjusted several times through comprehensive and practical field testing and consultation workshops.

In fact, this summary is not meant to envisage the purpose of technical design standards and various specifications only for labor intensive public works are given. The summary is presented as a reference guide and should be supported by other required technical references that will be better applied through field testing for specific conditions in Uganda.

Table 22.1 Minimum technical specifications and provisional work norm for labour intensive public works, adapted from Ethiopia

Type of Technologies or Practices	Unit	Provisional work-norm	Minimum Technical Specifications
Micro-basin Construction (moisture harvesting)	Micro-basin/PD ¹	5	<ul style="list-style-type: none"> • Diameter: Min 1 m and max 1.5 m. • Small stone riser: 0.2 m foundation and height 0.2 - 0.4 m above ground base on slopes, • Plantation pit: 30 cm diameter x 50 cm depth, • Soil sealing: sealed with soil from cut area, • Basins are constructed in staggered position between rows and in rather close spacing within a row in case of 1 m diameter basin (some overlapping required between rows).
Eyebrow basin construction (EB)	PD/2 EB	1	<ul style="list-style-type: none"> • Eyebrow basin has 2.2-2.5 m diameter, placed along the contours (staggered between lines). • Solid and well-constructed stone riser (or stabilized by brushwood or life fence): with 0.2 m depth foundation, height 0.4-0.6 m (based on land slopes), • Water collection area dug behind (or side off) plantation pit: 1 m width x 1 m length x 20-25 cm depth (lower side). Depth and size of water collection area may change based on available soil depth. • Stone riser sealed with soil from excavated area, • Plantation pit (s) of 30-50 cm depth x 30 cm diameter dug between riser and water collection area. • Drought resistant vegetation planted at lower part of stone riser if necessary and materials are available.
Water collection trench construction	PD/3 Trenches	2	<ul style="list-style-type: none"> • Average size of the trench: 2.5-3 m length x 0.5 m width x 0.5 m depth (downside). • Distance between trenches 2-3 meters average. Distance within line 0.5 meters. • Except for very permeable soils, trenches are provided with a 60 cm (width – along trench) x 25 cm (average depth) tie with a 40 cm x 40 cm x 40 cm deep plantation pit in the middle. • Make sure that plantation pit in the middle of the tie is 5-10 cm lower than the bottom of the trench for enhancing deep rooting system. 1 or 2 plantation pits can also be dug in front of the trench.

¹Person-day (PD) is the labor contributed by a person in a day.

Type of Technologies or Practices	Unit	Provisional work-norm	Minimum Technical Specifications
			<ul style="list-style-type: none"> Average maximum water holding capacity of each trench is around 0.6-0.75 m³.
Herring bone construction (HB)	PD/4 HB	1	<ul style="list-style-type: none"> Spacing: the structures are placed apart 3-4 m along the contour (staggered between lines) and have extended arms conveying water towards the planting area. A water collection ditch (1m x 1m x 0.3 m depth at lower side) is dug behind the planting pit (40 cm diameter x 50 cm depth). The tips of the extended arms are 3 m apart (average). The embankment has its maximum height downslope (0.4-0.5 m) and decreases to 20 cm at the end of the side arms.
Improved pits construction for dry areas	PD/5 improved pits	1	<ul style="list-style-type: none"> Average sizes of the improved pit: (1) 0.60 length x 0.6 width x 0.5 m depth (downside) or (2) 1 m length x 0.4 width x 0.5 depth. Other shapes equivalent to the pit volume are also possible. Distance between pits is 30-50 cm along the contour and 1.5-2 meters along the slope. A 40 cm x 40 cm x 40 cm plantation pit is planted in front of the pit in the middle of a shallow platform. Average maximum water holding capacity of an improved pit is approximately 0.2 m³. The distance between planting pits should be 2-3 times denser as for trenches (along the contours). This measure is suitable for semi-arid & medium rainfall areas.
Micro-trenches construction	PD/3 micro-trenches	1	<ul style="list-style-type: none"> Average size of the trench: 1.5 m length x 0.4 m width x 0.5 m depth (downside), Except for very permeable soils, trenches are provided with a small and low tie in the middle to regulate water flow (15 cm width). In this type of design, trees are not planted in the middle of the trench but in front of it. One or even two trees (one for fodder and one for wood for example) can be planted in one or two 40 cm x 40 cm x 40 cm deep plantation pit in front of the micro-trench. Average maximum water holding capacity of each micro-trench is around 0.3 m³.
Small farm dam construction (runoff water harvesting)	m3/PD	0.4	<ul style="list-style-type: none"> Reservoir capacity: min 5,000 m³ and max 50,000 m³. Fill/capacity ratio (volume of embankment: reservoir capacity): min. 1:5. Clay core wall included. Upstream face/wall side slope is 1:3. Downstream wall side slope is 1:2.5

Type of Technologies or Practices	Unit	Provisional work-norm	Minimum Technical Specifications
			<ul style="list-style-type: none"> • Reservoir capacity: min 5,000 m³ and max 50,000 m³. • Fill/capacity ratio (volume of embankment: reservoir capacity): min. 1:5. • Clay core wall included. Upstream face/wall side slope is 1:3. Downstream wall side slope is 1:2.5 • Stone rip-rap (inserted 30-40 cm into dam on the upstream face), up to crest level. • Grass seeding and sodding on downstream face/wall • Sand filter and collection pipe to be placed. • Spillway designed based upon maximum intensity of rainfall over 20-50 years (120-150 mm/hour suggested in case data are scarce) and estimation of runoff coefficient and concentration time. • Spillway free board: based upon site and dam design (see specific technical indicators). • Type of spillway: if not dug on stony side, the spillway should be stone rip-rap, with stones driven 30-40 cm into the soil at the bottom of channel. Spillway sides are 1horizontal to 1-2 vertical (z) and stone faced at least up to maximum permissible depth. • Outlet pipe required (sand filter at downside toe).
Water pond construction (runoff water harvesting)	m ³ /PD	0.5	<ul style="list-style-type: none"> • Excavated volume (reservoir capacity): min. 1,500 m³ – max. 5,000 m³. • Shape: either circular or rectangular. • The level of the collection channel should be 50 cm below maximum water level. • Depth: Minimum depth 4 m and maximum depth 6 m. • Maximum water level: ground level or slightly above only if embankment is well compacted and protected downstream with 0.5 –1 m high stone riser (1:3) on upper side of embankment. • Spillway: designed with free board height 0.5-0.75 m, and width based upon catchment area, runoff coefficient and max rainfall intensity. Spillway must be riprap and side protected. Drop structure + apron also needed. • Silt trap (min 2-4 m x 2-4 m width x 1-1.5 m depth) constructed min 10 m between end of interception drain and pond area. • Separate cattle trough needed (prevents pollution of pond water and water-borne disease). • Access path (stairs shaped against pond wall) for domestic use up to 0.5 meter from bottom of pond.

Type of Technologies or Practices	Unit	Provisional work-norm	Minimum Technical Specifications
Stream water diversion (for small scale irrigation)	PD/Pond	3000	<ul style="list-style-type: none"> • Dry fencing + vegetative fencing. • In case of a diversion dam, a permanent concrete structure should be considered. Very large diversion dams are not considered here and only small size (min 30-40 meters in length, max 3 m in height from crest to foundation and width crest of average 1.5-2 m) structures are envisaged. Similarly to the small farm dams described above, this activity is related to small-scale stream diversion structures identified by the community and technical institution, i.e. through the assistance of skilled district or regional experts. • Since project supports only labour requirements for the different operations, additional materials needed for stream diversion (like cement, reinforced iron, skilled masons, etc.) should be provided or envisaged from either the technical institution or other organizations willing to support the project. • The work norm may be estimated based on the following activities: removing of foundation materials, foundation and stone masonry work, stone collection, back filling and off take structure. Rather using the standard work norm, it is recommended to adapt the other work norms (excavation, stone collection, check dam, etc.) to accommodate the design of different diversion dams.
Spring water development (for domestic use & small scale irrigation)	PD/Spring	1700	<ul style="list-style-type: none"> • Minimum spring yield: 0.1 lt/sec. • Collection chamber: minimum 5 m³. • Sand & stone & gravel filter construction • Construction of cattle trough and paved area (3 meters radius minimum). • Construction of washing basin (min 2 m length x 0.75 m width divided into 3 compartments) and paved area & apron (min 1 m width on all sides) • Construction of stand pipe support and surrounds (paved area, collection niche, etc.). • Construction of night collection reservoir (optional). • Construction of water reservoir for small scale irrigation (based on overflow). • Fencing and digging of interception & protection drain.
Compost making (pit construction)	PD/Pits	10	<ul style="list-style-type: none"> • Compost making in a pit will include digging of a standard pit of 4 m length x 1.5 m deep x 2 m width pit (12 m³). • For each household or nursery using the pit system two pits are recommended.

Type of Technologies or Practices	Unit	Provisional work-norm	Minimum Technical Specifications
			<ul style="list-style-type: none"> The first pit is filled with layers overlaid as follows: <ol style="list-style-type: none"> 20-30 cm of roughage of decomposable organic waste materials (cereal straws, crop residues, husks, twigs, fallen tree leaves, etc.). Ashes (kitchen waste, burned weeds, etc.): 0.5 kg/m² of compost area + farm yard manure (3-5 kg/m²) + place a thin layer of soil (5 spadess/m²) + watering of the layer. The sequence is repeated until reaching the top of the pit. Then pits are covered with dry straws or grasses. A small protection drain is dug around the pit (or sides) to avoid runoff coming from homestead or any other direction to fall into the pit. Compost is turned and mixed into adjacent pit after one month. The compost remains in the second pit for around 2-3 months (or more) until ready. One month before the compost is ready, the first pit can be refilled with materials for a second round of composting. In this way, two to three compost making rounds can be achieved in one year.
Compost heap making (above ground)	PD/Linear meter	1	<ul style="list-style-type: none"> This activity includes digging of a shallow trench for the placement of the heap (0.15 m x 1.5 m wide x as long as materials allow), collection and transport of roughage, ashes, soil, and dung, layers making (roughage + ash + soil + dung), first watering, and shelter. Heap can be as long as desired and high up to 1.5 m
Manuring of planting pits	PD/200 pits	1	<ul style="list-style-type: none"> The activity includes collection and transport of manure & compost from homesteads to plantation sites (by bags or cart), distribution to pits (2-3 handfuls) and light mixing with some soil inside the plantation pit. The distribution to pits should be supervised by a development agent (DA).
Mulching of trenches/ eyebrow basins/herring bones, etc.	PD/50 structures	1	<ul style="list-style-type: none"> The activity relates to the cutting of grasses or roughage growing in the plantation area or in nearby sites (old closed area, etc.) as a result of closure and water harvesting effect. Usually, it is recommended to cut the grasses & roughage preferably before the whole rainy season is over or immediately after; and mulch each structure with a thick layer (min 15 cm) inside trenches, around plantation pit, water collection areas, etc. The work norm is the same for applications on Z trenches, eyebrows basins and herring bones. For normal micro-basins and improved pits a 50% additional number of structures is considered (75 structures).

Type of Technologies or Practices	Unit	Provisional work-norm	Minimum Technical Specifications
Soil bund construction	PD/km	150	<ul style="list-style-type: none"> • Height: min 60 cm after compaction (top level well shaped). • Base width: 1-1.2 m in stable soils (1 horiz: 2 vertical) and 1.2-1.5 m in unstable soils (1 horizontal: 1 vertical). • Top width: 30 cm (stable soil) – 50 cm (unstable soil). • Channel: shape, depth and width vary with soil, climate and farming system. • Ties (if appropriate): tie width with dimension as required, placed every 3-6 m interval along channel (only for level or contour bunds). • Gradient (for graded bunds): min 0.2% - max 0.6%.
Stone bund construction	PD/km	250	<ul style="list-style-type: none"> • Height: 70 – 100 cm (lower side). • Total base width: (height/2) + (0.3 to 0.5 m). • Top width: 30-40 cm. • Foundation: 0.3 m width x 0.3 m depth. • Grade of stone face downside: 1 horizontal: 3 vertical. • Grade of stone face upper side: 1 horiz: 4 vert. • Grade of soil bank (seal) on upper side: 1 horiz :1.5-2 vertical.
Stone faced soil bunds construction	PD/km	250	<ul style="list-style-type: none"> • Grade of lower stone face: 1 horizontal to 3 vertical. • Grade of upper stone face: based on soil embankment grade. • Grade of soil: 1 horiz. to 1.5 vertical on stable soils and 1 horiz. to 2 vertical on unstable soil. • Lower stone face riser foundation: 0.3 depth x 0.2-0.3 width. • Upper stone face riser foundation: 0.2 x 0.2 m. • Stone size: 20 cm x 20 cm stones (small and round shape stones not suitable). • Top width: 0.4-0.5 m. • Height: min. 0.7 and max. 1 m (lower stone face). • Ties required every 3-6 m (for contour or level).
Zai (planting pits) construction	PD/50 pits	1	<ul style="list-style-type: none"> • Zai pits are small pits dug along approximate contours in between bunds (bunds are a separate activity), usually at the end of the rainy season. • Each zai pit has 30-50 cm diameter and 15 cm depth. • During excavation the soil is placed on lower slope. • Spacing between pits within the row is 30-50 cm and spacing between two zai lines is 60-70 cm. • After construction, one spade of farm yard manure is added into each pit. • During the dry season twigs and leaves will be also transported by wind and fall into the pits where microorganisms, ants and other insects will start recycling organic matter up and down into the soil profile. • During first rains zai pits are planted with sorghum or millet which will be then harvested leaving 0.75-1 m high stocks above

Type of Technologies or Practices	Unit	Provisional work-norm	Minimum Technical Specifications
			<p>ground and removing the rest. Those residues will be turned manually and thrown into the pit.</p> <ul style="list-style-type: none"> • During second rainy season a legume plant is grown in the pit whilst another series of pits is dug in between the first year lines, thus completing the whole area in two years. • Number of zai pits per ha varies based upon density and size of pits, i.e. 10,000 – 25,000 pits per ha.
Fanya-Juu construction	PD/km	200	<ul style="list-style-type: none"> • Design specifications are same as soil bunds but channel dug on lower side and soil lifted upwards (suitable for soils > 1 m depth).
Planting on soil bund (sodding of bunds or bund stabilization)	PD/km	16	<ul style="list-style-type: none"> • Planting productive shrub seedlings assumes a minimum standard spacing between plants of 0.3 m in a single row placed on one side of bund (side of berm) or at its top. • Taking into account the standard minimum spacing indicated above, double row is also possible as well as closer spacing within row (0.2 m).
Hillside terrace construction	PD/km	250	<ul style="list-style-type: none"> • Height or stone riser: min 0.5 m (range 0.5-0.75 m). • Width of terrace: min 1.5 m (range 1.5-2 m). • Foundation: 0.3 m depth x 0.3 m width foundation. • Grade of stone riser: well-placed stone wall (grade 1 horizontal to 3 vertical). • In lower rainfall areas, hillside terrace have 5-10% gradient back slope. • Integration with micro basins or other structures in between terraces is recommended.
Cut-off drain construction	m ³ /PD	0.70	<ul style="list-style-type: none"> • Gradient: 0.5 – 1% max without scour checks. From 1 to 2% with scour checks. • Shape: Parabolic or trapezoidal. • Channel dimensions: as per the catchment area, runoff coefficient and type of soil (refer to technical documents). • Embankment: minimum 0.5 m top width, all slopes cut to grade of 1 to 1. • Scour checks (for gradients 1 – 2%). Scour checks raise 2-3 cm above channel floor. Laterally, the scour check rises up to the upper level of the freeboard. Scour checks constructed by either using straws or stones (placed every 2-3 m on the channel). • Outlet pitching with stones: 2-3 meters length of the bottom and sides of channel paved with stones + drop structure and apron. Outlet linked to a solid drop structure and ending into a large apron. Regarding the drop + apron structure refer to the new activity work norm.

Type of Technologies or Practices	Unit	Provisional work-norm	Minimum Technical Specifications
			<ul style="list-style-type: none"> Outlet pitching with straws: In absence of stones, a series of densely packed lines of scour checks made out of straws (10 cm width) should be dug & driven into the channel (every 0.4-0.5 m spacing on the channel) across the last 3 meters of the channel (approx. 6-8 rows). The drop structure should be ladder shaped and strengthened with wood posts inter-woven with small branches. The apron is a dense series of hard straws for at least 2 meters into the waterway.
Stone check-dam construction	m ³ /PD	0.50	<ul style="list-style-type: none"> Spacing estimated on the safe side using S (spacing) m = Height (m) x 1.2 gradient (in decimals). Side key: 0.7-1 m inside gully sides/gully walls. Bottom key & foundation: 0.5 m depth x width of check dam. Height: min 1m and max 1.5 m excluding foundation. Base width: min 1.5 and max 3.5 m. Stone face 1:3 to 1:4 for increased stability. Spillway (trapezoidal) with 0.25 m free board and 0.25-0.3 m permissible depth, width min 0.75 m and max 1.2 m (based on small catchments). Drop structures on steep slopes (above 10%) or unstable soils, (ladder placed stones up to half the height between apron and spillway level). Apron at least 50 cm wider on both sides of spillway fall (total width 1.5-2 m) and length towards water flow of minimum 1 m, with stones placed vertically and/or alternate rows.
Stone check-dam maintenance	m ³ /PD	1.0	<ul style="list-style-type: none"> Increasing spillway size: by min 0.2 m on all sides. Insertion of a drop structure: ladder shaped placed stones (better large and flat stones) from spillway level down to the bottom of the spillway chute. The width of the drop should be 25 cm larger than spillway width on both sides. Apron: 0.5 m width on both sides of spillway fall x 1 meter downstream (vertical shaped stones buried 20 cm deep into the soil). Side walls (optional): side walls protect the downstream part of the check dam from water that may fall from the gully sides and from strong overflow from spillway, which may side erode the gully and ultimately provoke the collapse of the structure. Side walls for small check dams usually extend 50 cm from the base of the check dam along the apron and rise up to spillway level.
Brushwood check dam construction	PD/3 linear meters	1.0	<ul style="list-style-type: none"> Brushwood check dams are designed in the same way as stone check dams but spacing between structures is usually half the one for stone check dams since they are less stable and resistant to water flow.

Type of Technologies or Practices	Unit	Provisional work-norm	Minimum Technical Specifications
			<ul style="list-style-type: none"> • They are recommended only on small gullies (usually max. 3-4 m wide and max. 2 m deep), and gully slope preferably < 20%. • Gully banks reshaped up to 1:1 side slopes • Materials are needed such as wood or bamboo posts and branches for inter-weaving. • In addition, vegetative materials (bamboo, elephant grass, Vetiver, Erithryna sp., Euphorbia, Sisal, etc.) should be planted at the lower side of the brushwood for further strengthening and gradual replacement of the function of the brushwood check dam after a few years. • Wood posts should be driven 50 cm into the soil and spaced apart 30-50 cm (inclined 1:4 back slope).
Gabion check dam construction	PD/0.25 m ³ gabion check dam	1	<ul style="list-style-type: none"> • For technical standards, reference to specific guidelines and skilled engineers' recommendations should be made. • Usually, a 1 m deep key trench as wide as the dam & structure should be excavated for proper stability (the same applies on side keys and walls). • The activity includes side and bottom key construction for gabion placement, anchorage, knotting, and filling. Filling is a delicate part and large voids should be filled with small stones.
Grassed waterway construction	m3/PD	1.0	<ul style="list-style-type: none"> • Dimensions: as per the catchment area, runoff coefficient and type of soil (refer to technical documents). • Shape: parabolic is preferable or trapezoidal (1 horiz: 1 vert.). • Depth: 0.3-0.5 meters. • Stabilization: rows of grass splits or seedlings placed every 2 m along the channel. An alternative to grass are 10 cm width rows of dry straws placed at 1-2 meters interval based on slope (by raising 3-5 cm above waterway channel, they slow down water flow and intercept velocity).
Seedling production	PD/1000 seedlings	15	<ul style="list-style-type: none"> • Results from combination of different measures: (1) Preparation of beds (2) Preparation of pots (3) Potting, (4) Transplanting, (5) Weeding (6) Root Pruning (7) Watering (8) Shading (9) Others.
Pitting	Pits/PD	15	<ul style="list-style-type: none"> • Diameter: 30 cm. • Depth: 30-50 cm. • Staggering of subsequent line of pits (preferable).
Seed collection	kg/PD	20	<ul style="list-style-type: none"> • Selection of healthy and vigorous mother tree seeds. • Collection of tree seeds at proper time (not fresh or old). • Removal from pods or cover, drying, seed extraction and removal of impurities.

Type of Technologies or Practices	Unit	Provisional work-norm	Minimum Technical Specifications
Seedling planting	Plants/PD	50	<ul style="list-style-type: none"> • Bagging and storage. • Preparation of running nursery or resting place. • Watering of seedlings before plantation. • Transportation to planting site (carrying, loading and unloading). • Removal & disposal of polythene tubes (if any). • Plantation, filling & compaction of soil around seedling.
Community road construction	PD/km	3000	<ul style="list-style-type: none"> • In case of areas without stones, layout of roads should not exceed 10% slope (occasionally up to 20% if those portions are surfaced with gravel). • Minimum width of road is 5 meters (excluding drain). • The road should be cambered towards drainage ditch (or on both sides – two drains) and stabilized with scour checks (brushwood). • Fords crossing: In absence of stones for proper stone paved crossing grader, fords should be crossed on tightly bound wood beams (framed by side posts) contributed by the community. • Downside of sloping curves reinforced with stone walls (if stones available) or wood posts interwoven with branches (+fill with soil). • Every 10 cm of soil layer from cut & fill should be strongly compacted with manual compactors. Acceptable wetting is recommended for compaction.
Community road maintenance or construction (on slope <5%)	PD/km	500	<ul style="list-style-type: none"> • Road maintenance includes reinforcements of outer side sloping curves (walls by stones or wood posts, etc.). • Re-shaping of road (cut and fill) for camber shape and strong compaction. • Excavation and stabilization of side drains (+ small stone & wooden checks). • Stable structures for crossing fords (stones, wood).
Grass & legume seed production (multiplication center)	PD/ha/year	700	<ul style="list-style-type: none"> • Fine seed bed preparation (essential for most seeds). • Planting of seeds and/or vegetative material, weeding, watering, cultivation, harvesting, drying, threshing, winnowing, bagging and storage.
Bund stabilization (grass and legumes)	PD/km	30	<ul style="list-style-type: none"> • Plantation in three rows on top and lower side of bunds (double row on top of bund) and one row in lower side of embankment. Middle row preferably of legumes. • If direct seeding is applied (medium & high rainfall areas) seeds planted at max. 1.5 cm depth on fine seed bed. • Grass splits or seedlings are preferred in most circumstances. Grass splits are planted at very close interval within the row (5-10cm apart) to form continuous row.

Type of Technologies or Practices	Unit	Provisional work-norm	Minimum Technical Specifications
Hillside terrace + trench Construction	PD/km	330	<ul style="list-style-type: none"> • The soil is excavated from the cut and fill and/or the trench, and reinforces and raises the embankment supported by the stone risers. • Stone riser height: 0.75-1 meters from ground level. • Stone riser foundation: 0.3-0.4 m depth x 0.3 m width. • Top width: 0.5 m (0.25 m stone riser and 0.25 m soil). • Grade of stone riser: 1 horizontal: 3-4 vertical. • Grade of soil bank: 1 horiz. : 1.5 vertical (unstable soils) to 2 vertical (stable soil). • Base width: based upon slope. • Size of upstream trench: 50 width x 50 cm depth x terrace length. • Within trenches ties are provided at regular intervals of 2-3 m based upon plantation requirements. Ties are usually (medium texture soils) placed half way the depth of the trench (0.25 m) with 0.6m horiz. length x 0.5 cm width) if planted with seedlings. If not ties are 15-20 cm width (to control water movement only) • A 30x30x30 cm plantation pit is placed in the middle of the tie or in front of the trench (between berm).
Gully revegetation	PD/ha	500	<ul style="list-style-type: none"> • Re-vegetation of a gully takes place after reshaping (1 horiz.:1 vertical minimum) of gully sides (you can apply the work norm mentioned for the activity). • Reshaping should be supplemented or directly implemented by shaping the gully sides into series of small steps or micro-benches (every 0.75-1m distance). • The gully sides should be planted with both a mixture of creeping and drought resistant grasses and tree & shrubs. Trees and shrubs should be planted at a density not lower than 4 m² and higher than 6 m² to reach dense vegetation as well as not to overshadow the grass growing the first year. • Grass should be planted in dense rows along the steps on simply on the reshaped gully sides. Do not plant grass in scattered spots.
Sediment storage dam (SS dam) construction	PD/m ³ earth/stone work	0.75	<ul style="list-style-type: none"> • Double stone faced wall on upper and downstream side of dam. • Relationship between height (H), length (L) and width (W) of dam as follows: H < 2 m H: BW (Height: Bottom Width ratio) is 1:2. Top Width = 1.5 m. H = 2-3.5 m H: BW (Height: Bottom Width ratio) is 1:2.5 Top Width = 2.5 m H = 3.5 – 5 m H:BW (Height: Bottom Width ratio) is 1:3. Top Width = 3 m. • V (approx.) = Volume of earth/stone work for embankment = H x (TW+BW) x (TL+BL) 4 TL = top length, BL = bottom length, TW = top width, BW = bottom with.

Type of Technologies or Practices	Unit	Provisional work-norm	Minimum Technical Specifications
			<ul style="list-style-type: none"> • Stone walls and foundation: made with large stones, starting from 1 m depth x 0.75 m width foundation on both sides, height up to maximum depth of water flow within spillway. • Side keys: driven 1 m inside gully sides. • Removal of first 10 cm of top soil for better merging & stability of earth embankment. • Cut & fill of gully sides for soil embankment formation (part of the dam embankment is also from the soil excavated from the spillway). • Spillway construction (see next measure). • Soil between stone raisers & walls well compacted (manually). • Achievements are reported in No of SS dams and earth/stone volume m³.
SS dams spillway construction	PD/m ³ spillway	0.50	<ul style="list-style-type: none"> • Trapezoidal structure is recommended. • Most spillways are dug on gully sides with harder material or need a stone rip-rap over their entire surface length and channel height. • A drop structure and a large apron is often required and up to the end of spillway. • For design of spillway see detail technical notes (manual). • The volume of spillway: length of spillway (generally equal to BW of embankment) x base width of spillway x total depth of channel, approximate estimation. • Achievements are reported in m³ and No of spillways.
Gully cut & fill/reshaping/leveling	PD/m ³ earthwork	1.0	<ul style="list-style-type: none"> • This norm is required to reshape gullies for accelerating sedimentation of SS dams. Being the soil dug from gully sides and dropping naturally on the lower portion of gully, the earth movement per person per day is higher. However, this norm includes also transport of soil from excavated site to various portions of gully and spreading & leveling.
Grassland improvement	PD/ha/year	20	<ul style="list-style-type: none"> • The grazing land is first overgrazed to reduce competition. • At 1m interval rows are ploughed or furrows opened along the contour (approx. 100 rows & furrows per ha). • Improved legume seeds are drilled into the furrows and lightly covered. • Alternate rows of grass and legumes are also possible. • Achievements are reported in ha.
Alley cropping	PD/km	10	<ul style="list-style-type: none"> • A great range of designs and spacing are possible. • Double row is considered. • Maximum spacing between alleys is 6-8 meters.

Type of Technologies or Practices	Unit	Provisional work-norm	Minimum Technical Specifications
			<ul style="list-style-type: none"> Plant density within row: 20-50 cm. Plant spacing between two rows of each alley: vary based on species. Tree & shrub seedlings are planted in shallow furrows on ploughed fields.
Degraded land & long fallows	PD/ha	250	<ul style="list-style-type: none"> For mulching, a standard 3-4 cm thick mulch is required. The work norm includes cut & carry and transport of mulch to site (distance 300 m from site max.) and layering of mulch over the entire area.
Grass stripping	PD/km	30	<ul style="list-style-type: none"> Under certain conditions, grass strips are nowadays established only by using splits or seedlings for the grass and seeds for legumes. A 0.5-1 m standard width three rows strip is considered (2 outer rows of grasses and one middle row of legume). Other options are also considered when particular grasses are planted such as Vetiver (one tight row of vetiver and one of legume shrubs)
Vegetative fencing & stabilization	PD/km	40	<ul style="list-style-type: none"> The activity includes fine seedbed preparation (fine plowing, removal of weeds), shallow furrows, planting of grass splits & seedlings close apart (10 cm) within row and light compaction around plants. Legumes are planted in a middle row, by direct seeding not deeper than 1.5 cm. The activity includes collection of planting material (available from site or nearby area), shallow pitting or furrowing, planting and soil compaction around plants. Double row is preferable (spacing 50 cm between rows and 20 cm within row), possibly using a combination of species like Euphorbia, Sisal, Aloe, Erythrina, bamboo, etc. In case of a single row (10 cm spacing average) they should be planted very close apart based upon local knowledge on what is necessary to obtain a tight and continuous vegetative fence.
Stone shaping (for SS & rock fill dam walls, large gully checks, etc.)	PD/0.5m ³ shaped stones	1	<ul style="list-style-type: none"> This applies to stones with diameter larger than 30-40 cm and height min 10-15 cm. Stones are shaped on minimum two sides. This activity is not intended to support hillside terraces or other stone faced measures which already include collection and selection of stones + light shaping with sledgehammer.
Stone collection and transport	PD/0.5 m ³	1	<ul style="list-style-type: none"> This activity is deliberately kept separated from movement of stones within short distance of the site because it considers the transport of stones from a distance ranging from over 75 up to 250 meters from the working site. Further distances need to be either relay or need the support of transport means (mules, carts, etc.).

Glossary of Terms

Accelerated erosion: The erosion much more rapid than natural erosion, primarily involving the loss of soil material from the land as a result of the interference of human activities.

Afforestation: The establishment of a forest on land that has not previously, or not recently been forested.

Agro-forestry: The integration of tree growing into the operation of an agricultural or farm lands, which involves planting trees or shrubs, or keeping those that are already there.

Apron: A layer of concrete, stone, timber, or other relatively permanent material placed at the entrance or outlet of a hydraulic structure, such as a culvert or chute, in the channel bed, to protect the structure against erosion.

Aquifer: A porous soil or geological formation, often lying between impermeable sub-surface strata, which holds water and through which water can percolate slowly over long distances and which yields ground water to springs and wells. An aquifer is any geological formation containing or conducting ground water, especially one that supplies the water for wells, springs, etc.

Arid: Refers to climates or regions which lack sufficient rainfall for crop production or extensive own pastures (usually defined as a climate with annual average rainfall less than 250 mm).

Artificial waterway: A water disposal area requiring constructed retaining bank or channel excavation/shaping to contain runoff.

Bench terrace: An artificial land terrace with flat top and often nearly vertical side used to convert hillside slopes to arable land, which is usually constructed on medium to steep slopes. A bench terrace is a level or nearly a level step constructed along the contour, which is separated by an embankment known as a riser.

Biomass: The quantity of living material present at a given time within a given area, such as the weight of vegetative matter removed by clipping a quadrat, which would include all living material, whether of plant or animal origin.

Buffer zone: Any area of land used or designed to isolate one area of land from another so that adverse effects arising from one area do not affect the other.

Catchment drain: A drain extending beyond the natural catchment of a dam in order to augment the supply of runoff to it.

Catchment: The area determined by topographic features within which rainfall will contribute to runoff at a particular point under consideration.

Channel stabilization: The implementation of appropriate vegetative or structural measures to prevent or mitigate erosion in a channel.

Channel: A passage in which water is confined sufficiently to temporarily hold it or allow it to flow from one place to another, given a sufficient head between them.

Check dam: A small structure constructed across a gully to slow down water flow in the gully and thereby reducing stream and river bank erosion in the downstream.

Compaction: The process of increasing the density of a material by removing air and inducing the closer packing of its particles, which may be achieved by rolling, tamping or other mechanical means, and leads to a reduction in the porosity of the material.

Compost: A mixture of organic residues such as decomposed vegetation, manure used as organic fertilizer.

Conservation farming: A system of farming which involves using the land in accordance with its capability and suitability and managing the land in accordance with the principles of conservation, which would include contour farming, conservation tillage, crop and pasture rotation, pasture improvement, strip cropping, and soil or water conservation works and practices where appropriate.

Conservation: The management of human use of the biosphere so that it may yield the greatest sustainable benefit to present generations while maintaining its potential to meet the needs and aspirations of future generations.

Contour bank: A bank that is constructed along the true contour, its channel being level, and which discharges at either or both ends depending on design requirements.

Contour ditch: A ditch dug along the contour to stop water from running down the slope causing erosion.

Contour farming: This is a ploughing and planting along the contour or across the slope rather than along the contour (or rather than up and down).

Contour: An imaginary line on the surface of the earth connecting points of the same elevation.

Culvert: One or more adjacent enclosed conduits for conveying runoff under a roadway or other structure.

Cut off ditch: A contour like ditch that has a slight slope to slowly drain away water.

Cut off drain: This is a ditch dug across a slope to intercept surface runoff and carry it safely to an outlet such as a canal, or stream. This structure is used to protect cultivated land and a road from uncontrolled runoff, and to divert runoff water from gully heads.

Dam: A barrier, embankment or excavated earth structure, generally built in or near a flow line, which has the primary function of impounding water for storage.

Deep well: A machine drilled well or borehole with a depth greater than 15 meters depth.

Degradation: A decline in the quality of natural resources commonly caused by human activities.

Design capacity: The calculated volume and discharge rate of a soil conservation structure, which is based on a given set of hydrological conditions applicable to the site and the requirements of the structure.

Design peak discharge: The maximum discharge, calculated for a given set of hydrological conditions, which is used in the design of a hydrological structure that can cope with those conditions.

Design storm duration: The storm duration selected in order to design specific soil conservation or hydrologic structures, normally taken as being equal to the time of concentration of the catchment concerned.

Diversion bank: A bank specifically designed to divert water, normally to protect a cultivated area, a gully, an eroded area, work or facility below, or to carry runoff to or from a dam or waterway away from the natural drainage line.

Diversion channel: An earth channel traversing a slope designed to protect adjacent lower slopes or development works by intercepting surface water and diverting it to a stable outlet.

Drain: A channel for the purpose of interception and removal of excess surface or sub-surface water to a stable outlet.

Earthwork: An earthen structure designed and constructed for the purpose of interception, diversion, retention, detention and safe disposal of runoff, or any similar soil conservation purpose.

Embankment: An artificial elevation of earth, longer than its wide, typically constructed for the purpose of controlling the flow of, or storing water as in a bank or dam.

Enclosure: An area of range land from which domestic and native animals are excluded for the purpose of studying the effects of no grazing on vegetation.

Erosion control measure: An activity based on structural work, vegetation management, tillage operations and other farm management options designed primarily to achieve control of soil erosion.

Erosion mitigation: Reduction in the severity of erosion, which is a general term used to embrace all those activities, including specific soil conservation activities, aimed at the control of soil erosion and the reduction of its impact on all forms of land use.

Erosion: The wearing away of the soil by running water, rainfall, wind, or other geological agents, including such processes as detachment, entrainment, suspension, transportation and mass movement.

Erosive velocity: Velocity of the erosive agent necessary to cause erosion of the material in question.

Evaporation pan: A shallow open container from which daily changes in water level are used to calculate natural evaporation from a free water surface.

Evapotranspiration: Removal of moisture from soil by evaporation plus transpiration by plants growing in that soil, which is measured at a specific site over a specific period of time.

Fanya Juu terrace: This is a conservation structure made by digging a trench along the contour by throwing the soil uphill to form an embankment, which develops into bench terrace over time.

Floodplain: A large flat area, adjacent to a watercourse, characterized by frequently active erosion and aggradation by channeled or overbank stream flow.

Foot slope: A moderate to very gently sloping land form at the lower end of a slope, resulting from aggradation or erosion by sheet flow, earthflow or creep.

Freeboard: The vertical distance between the top water level and the crest of a bank, dam or similar structure.

Gabion: A rectangular wire mesh cage filled with rock, brick or similar material, which is usually assembled on site, securely tied together and used in the construction of retaining walls and anti-erosion structures.

Grade: The degree of slope of a constructed or excavated surface such as a road or batter, which may also be applied to the longitudinal fall of a channel such as in a diversion bank, drain or watercourse.

Graded bank: A bank built with a design fall along the channel to allow water to flow in a specified direction.

Grassed waterway: A grassed waterway is a broad, shallow and typically saucer-shaped channel designed to move surface water across farmland without causing soil erosion.

Groundwater: Subsurface water contained in a saturated zone of the soil or a geologic stratum, which is at a pressure equal to or greater than atmospheric pressure and will therefore flow out into a well or at the earth's surface.

Gully control structure: A constructed wall or other barrier of earth, concrete, masonry, wooden, or sand filled sacks incorporating a stable outlet, which entraps runoff in a gully or drainage line as part of a scheme of gully erosion control.

Gully erosion: A complex of processes whereby the removal of soil is characterized by large incised channels in the landscape, which is generally more than 30 centimeters deep.

Gully filling: Placing material, by mechanical means, in a gully to raise its floor, and subsequently shaping it to a uniform cross-section and stabilizing it to minimize the potential for further erosion.

Gully head: The upstream end of a gully where runoff from the catchment above falls to the gully floor, which is the exposed part of the gully upon which erosive forces, including water flow, splash and seepage, act to cause the gully to extend upstream by head ward erosion.

Gully shaping: Physical reorientation of the sides of a gully, by mechanical means, to create a uniform cross-section that will cater for expected flows, without substantially raising the level of the gully floor.

Gully: An open incised erosion channel in the landscape generally greater than 30 cm deep, which is characterized by moderately to very gently inclined floors and precipitous walls.

Head ward erosion: Gully enlargement in an upstream direction due to incision by concentrated runoff and the formation of a waterfall and splash pool leading to undercutting and slumping of the gully head, which may be accentuated by the effects of sheet and splash erosion, and subsurface seepage.

Horizontal interval: The horizontal distance from one soil conservation structure to another.

Impervious: Describes a soil through which water, air, or roots penetrate slowly or not at all.

Infiltration basin: An excavation in highly permeable soils to temporarily store runoff directed into it, which is normally excavated at or very close to the source of runoff.

Infiltration ditch: This is a structure designed to harvest water from roads or other sources of runoff to seep it into the soil.

Infiltration: The downward movement of water into the soil, which is largely governed by the structural condition of the soil, the nature of the soil surface including presence of vegetation, and the antecedent moisture content of the soil.

In-situ: A term meaning ‘in place,’ and is normally applied to rocks, fossils and soils which are situated in the place where they were originally termed or deposited. The term is normally applied to rocks, fossils and soils which are situated in the place where they were originally termed or deposited.

Key: A lateral trench dug into the sides of a gully to prevent water flow from gouging soil out from the sides of the check dams.

Labour intensive: A method of construction of technically and economically feasible labourbased activities by utilizing hand tools and light construction equipment.

Land degradation: A temporary or permanent decline in the productive capacity of the land or its potential for natural resources management, which is commonly caused through improper use of the land by humans. Land degradation encompasses soil degradation and the deterioration of natural landscapes and vegetation.

Land management: The application to land of cultural, structural, vegetative or any other types of measures, either singly or in combination in order to achieve a desired land use.

Land use planning: The conscious pursuit of goals, relating to the purpose for which land may be used by means of the formulation and implementation of strategies, policies and programs based on scientific and technical studies.

Landscape: That part of the land’s surface, more or less extensive, being viewed or under study that relates to all aspects of its physical appearance, including various vegetation associations and landforms.

Landslide: A general term used to encompass the types of mass movement where the material is displaced downslope and along distinct surfaces of separation. The term encompasses a wide variety of materials but relates specifically to slope failures that involves the ‘sliding’ of the moving material over the ground surface.

Lateral erosion: Gully enlargement in a lateral direction due to incision by concentrated runoff entering at the gully sides or by undercutting and slumping or by sheet, rill and splash erosion of the gully sides.

Mulch: A natural or artificial layer of plant residue or other material on the soil surface, which provides protection against erosion and helps plant establishment mainly by restricting moisture

loss. It may also increase infiltration and minimize temperature fluctuations.

Mulching: The application or retention of mulch, usually refers to the application of mulch to disturbed areas as a temporary expedient to assist the establishment of permanent vegetative cover, or the retention of plant residues on arable land between cropping phases to assist in erosion control.

Natural resource: The naturally occurring components of the environment which are of value to the human population, including land, soil, water, flora, fauna, minerals and energy sources.

Natural waterway: A water disposal area where runoff naturally flows or can be made to do so without constructed retaining banks or channel excavation/shaping.

Negarim Micro-basin: A diamond shaped basin surrounded by small earth bunds with an infiltration pit at its lowest corner.

Pan evaporation: The depth of evaporation from a free water surface determined by use of an evaporimeter and expressed in millimeters. The figure is used to estimate evapotranspiration in field areas and for water balance studies.

Peak discharge: The maximum discharge resulting from a set of hydrological conditions.

Perched water table: The surface of a local zone of saturation held above the main body of groundwater by an impermeable layer, usually clay, and separated from it by an unsaturated zone.

Physical soil conservation: This is a structure made of earth, stones, or masonry, which is designed to protect the soil from uncontrolled runoff and erosion and retain water where it's needed.

Pitting: Is the making of shallow pits or depressions in the soil, of suitable capacity and distribution, to retain water from rainfall for planting purpose.

Public work: An activity designed to provide employment opportunity to communities through a public program.

Rainfall intensity: The rate of rainfall for any given time interval, usually expressed in millimeters per hour (mm/h).

Re-afforestation: The re-establishment of a forest on land from which a previous forest has recently been cleared or destroyed.

Regeneration: The re-establishment of depleted vegetation by natural self-seeding and regrowth. It is commonly associated with stands of native species that have been logged or partially cleared, burnt or depleted in some way and that are being encouraged to return to their natural condition.

Rehabilitation: The treatment of degraded or disturbed land to achieve an agreed level of capability and stability, preferably at least equal to that which existed prior to degradation or disturbance.

Restoration: Rehabilitation of degraded or disturbed land so that, not only are the former capability and stability re-established, but also the form and usage of the land are returned to a state closely resembling that before degradation or disturbance.

Retaining wall: A barrier, usually of uniform thickness and constructed of masonry materials, designed and installed to hold back unconsolidated rock or soil. Its aim is to control the gravitational force of the material it is withholding and prevents mass movement.

Retention ditch: This is a ditch dug along the contour to catch and retain incoming runoff and hold it until it seeps into the ground. Retention ditch is an alternative to a cut-off drain when there is no nearby waterway to discharge the runoff.

Revegetation: The re-establishment of plants on an area of ground that is depleted or devoid of vegetation in order to provide protection against erosive agents. It is an integral part of erosion control and prevention on a wide variety of disturbed, eroded and degraded lands.

Rill erosion: The removal of soil by runoff from the land surface whereby numerous small channels, generally up to 30 centimeters deep are formed. Typically occurs on recently disturbed soils.

Rip-rap: Loose rock or stone used to protect earth surfaces against erosion by flowing water or wave action as in a revetment.

River training: A method of using structural measure to prevent and mitigate flash flood and river bank erosion problems.

Roadside erosion: Soil erosion associated with the presence of a road across a landscape. Such erosion may be directly caused by the road, or may be existing erosion aggravated by the location, nature or construction of the road.

Run on: Surface water flowing onto an area as a result of runoff occurring higher up the slope. It is also used in semi-arid areas to refer to surface water which is diverted from sloping areas onto flatter land to achieve increased production from such land.

Runoff: That portion of precipitation not immediately absorbed into or detained upon the soil and which thus becomes surface flow. Runoff is the major agent of water erosion particularly on filled soils. The amount of runoff depends on rainfall intensity and duration, land slope, surface roughness, vegetative cover and surface soil conditions including moisture content.

Saturated or phreatic zone: It is the earth's crust or region where all available spaces are filled with water.

Sediment discharge: The quantity of sediment, measured in dry weight per unit time, transported through a channel cross-section.

Sediment load: The sediment carried in flowing water, including sediment in suspension and bedload.

Sediment or silt trap: A structure, usually relatively small, designed specifically to collect sedimentary material in a drainage line. Sediment traps should be regularly cleaned out to maintain their efficiency.

Sediment: Material of varying size, both mineral and organic, that is being, or has been moved from its site of origin by the action of water, gravity, or wind, and comes to rest on the earth's surface either above or below sea level.

Seepage: The process by which water percolates downwards and laterally through the soil, often emerging at ground level lower down a slope. The term is frequently used in relation to the percolation of water through a constructed earth wall.

Shallow well: A shallow hole which is dug, bored, or drilled into the ground for the purpose of extracting water.

Shaping: Physical reorientation of land surface materials by mechanical means to produce a preconceived landform.

Sheet erosion: The removal of a fairly uniform layer of soil from the surface by raindrop splash or runoff.

Side slope: That section of a hillslope which comprises the middle and upper slopes where soil processes are usually transformational. A side slope generally lies between a hill crest and a foot slope, supplying depositional material for the latter.

Soil bund: A ridge and ditch made of soil, dug across the slope along the contour, which is used to prevent run-off and conserve soil and water.

Soil conservation: The prevention, mitigation or control of soil erosion and degradation through the application to land of cultural, vegetative, structural and land management measures, either singly or in combination, which enable stability and productivity to be maintained for future generation.

Soil erosion: The detachment and transportation of soil and its deposition at another site by water, wind, or gravitational effects. Although a component of natural erosion, it becomes the dominant component of accelerated erosion as a result of human activities, and includes the removal of chemical materials.

Spillway: An open or enclosed channel, or a combination of both, used to convey excess water or runoff from a dam or similar storage, gully control structure or detention structure.

Splash or raindrop erosion: The spattering of soil particles caused by the impact of raindrops on the soil. The loosened particles may or may not be subsequently removed by runoff. This is an important component of sheet erosion.

Spring: It is the result of an aquifer being filled to the point that the water overflows onto the land surface.

Stilling basin: The pond located at the foot of an overflow, pipe, flume, spillway or similar structure to reduce the energy of the descending stream of water and associated turbulence, subsequently reducing outlet velocities to a non-erosive level.

Stone Bund: A ridge and ditch made of stones, dug across the slope along the contour, which is used to prevent run-off and conserve soil and water.

Storm water: The rainwater plus anything the rain carries along with and runs on the surface as runoff and ends up in nearby streams, rivers, or other waterbodies.

Streambank erosion: The removal of soil from the banks/sides of the stream by the direct action of stream flow, or wave action, which typically occurs during periods of high flow.

Streambank: A laterally extensive, moderately inclined to precipitous slope forming the margin of a stream channel and resulting from erosion or aggravated by channeled stream flow.

Surface detention: The depth of water temporarily held on the land surface while moving freely downslope, before being transferred to the category of infiltration, channel or depression storage.

Tank: A water storage, typically excavated in level or gently sloping terrain, in which a large percentage of the capacity is below ground level.

Technical manual: A guiding document containing technical description for the design and implementation of labour intensive public works.

Terrain: A tract of land having particular physical features.

Tied ridge: Semi-permanent ridge along the contour, with short cross-tie to prevent water from flowing along the furrows between the ridges.

Trainer bank: A bank constructed to prevent flows from spreading or to direct runoff away from an undesirable location or towards a stable outlet. Such a bank is designed so that runoff flows on natural vegetation and will only be guided or contained by it.

Training module: A standard or self-contained guidance that constitutes a structured and on-the-job training program.

Tree nursery: A place where different plants are propagated and grown to usable size. A nursery activity may be owned by general public, businesses, commercial gardeners and private individuals.

Trench: A long narrow excavation generally with uniform cross section, excavated by human activity.

Uniform flow: Flow in which the depth and velocity remain constant with respect to distance.

Unsaturated zone: It is the earth's crust or region where there are still pockets of air that contain some water, but can be filled with more water.

V-notch: An overflow structure designed to allow measuring of flows to pass directly over it once the pool is full.

Water Conservation: It is a way of trapping as much as water and storing it in tanks, or reservoirs, which increases the amount of water seeping into the soil, reducing the speed and amount of water running off.

Water erosion: An erosion process in which soil is detached and transported by the action of rainfall, runoff, or seepage.

Water harvesting: A method for inducing, collecting, storing and conserving local surface runoff for agriculture and domestic use in arid and semi-arid areas.

Water table: The upper surface of unconfined groundwater below which the pores of rock or soil are saturated, or it is the surface where the pressure head is equal to atmospheric pressure.

Watershed management: An integration of technologies within natural boundaries of a drainage area for optimum development of land, water and plant resources to meet basic needs in a sustainable manner.

Watershed: Any surface area from which runoff resulting from rainfall is collected and drained into a common point or an outlet.

Waterway: A stable longitudinally sloping water disposal area of sufficient capacity used to discharge surplus runoff and to allow it to flow to a lower level without causing erosion. The runoff would normally be concentrated by the landscape above or by soil conservation banks or gully control structures which feed into the waterway. Waterway is designed to link up to the natural drainage system of the area.

Weir: A structure or wall built across a flowline or stream to raise the water level to allow diversion or measurement of discharge rate.

Zai pit: It is a hole dug approximately 80 cm apart to a depth of 5 to 15 cm, with a diameter of between 15 and 50 cm, which improves infiltration of the captured runoff.

References

- 17 May 2013. International Federation of Red Cross and Red Crescent Societies. Disaster Relief Emergency Fund (DREF). Uganda, Kasese Floods.
2005. Community Based Participatory Watershed Development: A Guideline Part 1. Ministry of Agriculture and Rural Development. Addis Ababa, Ethiopia.
2005. Community Based Participatory Watershed Development: A Guideline Part 2. Ministry of Agriculture and Rural Development. Addis Ababa, Ethiopia.
2009. NUSAF2 Public Works Programme (PWP) Handbook. Government of Uganda, Office of Prime Minister.
2010. Water and Environment Sector Performance Report. Ministry of Water and Environment, Kampala, Uganda.
2014. Food Security and Nutrition Network Social and Behavioral Change Task Force. CareGroups. A training manual for Programme Design and Implementation. Washington, DC. Technical and Operational Performance Support Programme.
2014. Uganda Social Protection Sector Review. Government of Uganda, Ministry of Gender Labour and Social Development.
- Adele Harmer. GIZ, May 2012. Cash and Voucher for Work in Food Security Programmes, Lessons Learned from Karamoja, Uganda.
- Anil Agarwa. Drought. Try Capturing the Rain. Briefing Paper for Members of Parliament and State Legislature. An occasional Paper from the centre for science and environment.
- Anon (1967). Glossary of Soil and Water Terms. Special Publication SP.04-67. American Society of Agricultural Engineers, Michigan, U.S.A.
- April 2003. Labour Intensive Public Works. Towards Providing Employment for all South African Willing to work.
- April 2008. National Labour Intensive Public Works Strategy. Republic of Rwanda. Ministry of Local Government, Kigali.
- April 2010. Making Public Works. Social Protection Discussion paper Series. The Design and Implementation of Public Works Programmes. A toolkit for Practitioners. The World Bank, Human Development Network: Social Protection.
- April, 2013. Best Practices and Principles of MERET Project and its Future Strategic Orientation. WFP, Ministry of Agriculture, Water and Land Resource Centre for Environment and Development, University of Bern.
- Arega Yirga. 2004. Hand Notes 1-2-3 on Spring Development and Farm Pond Construction, Small Scale Water Harvesting and methods for Irrigation. World Food Programme, Addis Ababa, Ethiopia.
- Arega Yirga. July 2013. Manual on Design and Construction of Bench Terraces. Addis Ababa, Ethiopia.
- Arega Yirga. September 2010. Soil and Water Conservation Toolkits. Guideline for Technical Field Staff. Toolkit No. 1. Addis Ababa, Ethiopia.

- Betru Nedesa. 2004. Ecological, Technical, and Socio-economic issues of Area Closure Management Case Studies from four regional states. MOARD/MERET, Addis Ababa, Ethiopia
- Denana, D. 1996. Runoff Management and Erosion Control Measures in High Rainfall Areas. Ministry of Agriculture, World Food Programme, Addis Ababa, Ethiopia.
- F. D. Houghton and P. E. V. Charman, 1986. Glossary of Terms used in Soil Conservation.
- FAO. 1985. FAO Watershed Management Field Manual. Slope Treatment Measures and Practice. No.13/3FAO, Rome.
- FAO. 1986. FAO Watershed Management Field Manual. Gully Control. No. 13/2. FAO, Rome.
- FAO. 1987. Soil and Water Conservation in Semi-arid Areas. No. 57. FAO, Rome.
- FAO. 1987. Soil Management: Compost Production and Use in Tropical and Subtropical Environments. No. 56. FAO, Rome.
- FAO. 1988. FAO Watershed Management Field Manual. Landslide Prevention Measures. No. 13/4. FAO, Rome.
- FAO. 1988. FAO Watershed Management Field Manual. Road Design and Construction in Sensitive Watersheds. No. 13/5. FAO, Rome.
- February 2009. The World Bank and Government of Ethiopia. Impact Assessment of the Productive Safety Net Programme (PSNP) Public Works Programme, Addis Ababa, Ethiopia.
- Forster, H. (2002). Guidelines for the Development of Management Plans for Area Closures in Tigray Bureau of Agriculture and Natural Resource. Tigray, Ethiopia. 250
- Government of Uganda. Ministry of Gender, Labour and Social Development. 2014. Public Works Stakeholders Workshop Proceeding.
- Hanspeter Liniger (et al). Best Practices for Sustainable Land Management. Land Degradation Assessment in Dry Lands (FAO/GEF).
- Jack T. Chow, ACF Water Harvesting consultant. ACF. Karamoja Water Harvesting Field Guide. Jan Nyssen (et al). September 2007. Lessons Learnt from 10 Years Research on Soil Erosion and Soil and Water Conservation in Tigray. Tigray Livelihood Paper No. 7. Mekele University, Zala Daget Project.
- January 2008. OCHA, Uganda. Uganda Floods Lessons Learnt Workshop. Final Report.
- July 2005. Expanding Public Works Programme Contributing to a Nation at Work. Guideline for the Implementation of Labour Intensive Infrastructure Projects under the Expanded Public Works Programme (EPWP).
- June 2012. Government of India, Central Water Commission. Handbook for Flood Protection, Anti-Erosion and River Training Works. New Delhi, India.
- Leslie A. Simpson Ph.D. July 2010. Caribbean Agricultural Research and Development Institute (CARDI),
- A Manual of Soil Conservation and Slope Cultivation. Ministry of Natural Resources and Environment, Forestry Department.
- Leul Kahsay and Lakew Desta. 2004. Training Manual on Water Harvesting Structures.

Ministry of Agriculture and Rural Development, Addis Ababa, Ethiopia.
 March 2005. Labour-based Methods and Technologies for Employment Intensive Construction Works.
 A cidb Guide to Best Practices-Part 1.

Ministry of Agriculture and Rural Development. 2003. The New Coalition for Food Security Programme,
 Volume 1. MOARD, Addis Ababa, Ethiopia.

Ministry of Agriculture and Rural Development. 2004. The national Productive Safety Net Programme.
 MOARD, Addis Ababa, Ethiopia.

Ministry of Agriculture and Rural Development. 2011. Revised Project Implementation Manual for
 Sustainable Land Management Programme. MOARD, Addis Ababa, Ethiopia.

Ministry of Agriculture. 2012. Productive Safety Net Programme Pastoral Area Public Works.
 A Guideline. MOA, Addis Ababa, Ethiopia.

National Project Service Unit. 2002. Strategic Directions and Steps to Enhance Land Rehabilitation,
 asset creation, and livelihood improvement initiatives. NPSU, MOA, WFP, Addis Ababa, Ethiopia.
 November 2012. MERET Impact Evaluation Report. TANGO International and Institute of
 Development Studies. World Food Programme, Ministry of Agriculture, Addis Ababa, Ethiopia.

November 2011. The Republic of Uganda. Ministry of Water and Environment.
 National Irrigation Master Plan for Uganda (2010-2035). Final Report.

Rain Water Harvesting and Conservation Manual. Government of India. Consultancy Service
 Organization, Central Public Works Department. New Delhi, India.

Sara J. Scherr and Satya Yadav. International Food Policy Research Institute. Land Degradation in
 Developing
 World: Implication for Food, Agriculture, and the Environment to 2020.

Sayer, J and B. Campbell. 2004. The Science of Sustainable Development. Cambridge University Press,
 Cambridge, UK, 268 pp.

September 1999. Volli Carucci, Betru Nedessa, Arega Yirga. Guidelines for the Preparation of a
 Community-based and Integrated Land Rehabilitation Programme. A Trainers Manual. World Food
 Programme, Ministry of Agriculture, Addis Ababa, Ethiopia.

September 2002. Revised Soil and Water Conservation Work Norms (Summary). Ministry of
 Agriculture, World Food Programme, Addis Ababa, Ethiopia.

September 2004. Tefera Mengistu (et al). The Role of Communities in Closed Area management.

September 2013. Ministry of Agriculture, Animal Industry and Fisheries (MAAIF). National Agriculture
 Policy. Kampala, Uganda

Sue Laver. Well Digging. 2009. A Guide to the Construction and Protection of Hand Dug Wells.
 Tesfaye Teklu, Labour Intensive Public Works. The Experience of Botswana.

World Food Programme. 2003. Notes on Water Harvesting: The Productive and Sustainable Use of water
 and Soil in Complex Landscapes. WFP, Addis Ababa, Ethiopia.

World Food Programme. 2011a. The Northern Uganda Social Action Fund (NUSAF2),Karamoja
 Sub-region Programme Guideline for the Implementers.

Ministry of Gender, Labour and Social Development
Kampala, Uganda



**World Food
Programme**



**WORLD BANK
GROUP**



Irish Aid

Department of Foreign Affairs
An Roinn Gnóthai Eachtracha